

Distribution Transformer with Multi-Zone Voltage Regulation for Smart Grid System Application

Ryszard Strzelecki

*Faculty of Electrical and Control
Engineering
Gdańsk University of Technology
Gdańsk, Poland
ryszard.strzelecki@pg.edu.pl*

Wojciech Matelski

*Faculty of Electrical and Control
Engineering
Gdańsk University of Technology
Gdańsk, Poland
wojciech.matelski@pg.edu.pl*

Robert Małkowski

*Faculty of Electrical and Control
Engineering
Gdańsk University of Technology
Gdańsk, Poland
robert.malkowski@pg.edu.pl*

Valentin Tomasov

*Faculty of Control Systems and
Robotics
ITMO University
Sankt Petersburg, Russian Federation
tomasov@ifmo.ets.ru*

Leszek Wolski

*Department of Power Electronics and
Electric Transport
Electrotechnical Institute
Warsaw, Poland
leszek.wolski@iel.pl*

Antoni Krahel

*Department of Power Electronics and
Electric Transport
Electrotechnical Institute
Warsaw, Poland
antoni.krahel@iel.pl*

Abstract— The article presents four concepts of the multi-zone voltage regulation (MZVR) system. It is a combination of a distribution transformer with an on-load tap-changer, for step voltage regulation, and a power electronic converter, dimensioned for a fraction of MZVR power, realizing continuous voltage regulation, supplemented by a special switch, the so-called bypass. This allows voltage regulation at high resolution, wide range and with high dynamics and increased reliability. The work contains selected computer simulation results of the continuous regulation system, and considerations about extending the MZVR continuous voltage regulation range and its power level.

Keywords—power transformers, power distribution, smart grid, power electronics, hybrid power transformer

I. INTRODUCTION

In the last decades, a number of phenomena have been observed in the Power System (PS) causing deterioration of the Power Quality (PQ). This state of affairs is associated, among others, with the increasing number of induction motors, as well as the increase of non-linear loads supplied by power electronic converters, or various dynamic appliances, including high-speed EV chargers. The impact of distributed generation sources, especially renewable energy, is also significant [1]. As a result, the voltage value in distribution networks deviates from its nominal value, and the intensity of this problem has an unchanged upward trend. Therefore, the installation of various devices improving PQ is becoming more and more important [2].

II. VOLTAGE REGULATION SYSTEMS

One of the main elements of the PS is the Distribution Transformer (DT). In its basic form it is possible to change its voltage ratio by selecting another tap, usually in the absence of power supply. In order to ensure effective control of the grid voltage level, other regulating devices, denoted as Automatic Voltage Regulator (AVR) are also proposed [1]. The widest regulatory possibilities are enabled by the use of the so-called Solid State Transformer (SST) [3-6]. However, the costs and losses of these systems are approximately 4 times and approximately 3 times higher than in the case of a standard DT [7]. Therefore, the application of SST in typical AC networks at the moment does not find sufficient justification. On the other hand, the classic DT transformer is a device with a technology developed for over a hundred

years, thanks to which it is characterized by high reliability and very low power losses, even below 2%. For this reason, the DTs are supplemented with systems that enable on-load voltage regulation. As a result, integral solutions are obtained, which, due to the method of operation, can in principle be divided into Step (SRS) and Continuous (CRS) voltage Regulation Systems. Solutions containing semiconductor components are often referred to as Hybrid Transformers (HT).

Currently, despite such disadvantages as arcing, high operating costs, and slow operation, mechanical tap changers are the standard solution [8-9]. However, in terms of dynamics, much better parameters have devices in which semiconductor switches, mainly thyristor switches [10-12], are used instead of mechanical switches. These systems eliminate arc problems, and an important advantage is their commercial availability [13]. However, voltage regulation is still taking place in a step manner, and improving the resolution significantly increases the cost of the solution.

Among the known systems of continuous voltage regulation, in literature, essentially three groups of solutions can be distinguished. The first group are electromechanical voltage regulators with servo-mechanisms [2]. Disadvantages of the solutions from this group are high price, low reliability and poor dynamics. The second group of AVR solutions with continuous voltage regulation contains the so-called direct AC voltage converters [14-17], however which are characterized by many significant disadvantages. In particular, such drawbacks include a limited area of application mainly 3-wire networks, equality of input and output instantaneous active powers, and large amount and problems with commutation of required bi-directional AC switches. The last group consists of systems with AC/DC/AC power electronic converters with an intermediate DC current circuit [7, 18-22], which allows for: applying the solution to both 3-wire and 4-wire networks, connecting DC sources (including renewable sources or electric energy storage) and reactive power compensation.

The possibilities of continuous voltage regulation are usually a fraction of the nominal value of the output voltage, in the range of $\pm (10\% - 15\%)$.

In order to increase the voltage regulation range, while maintaining high resolution, it is proposed to combine the

CRS system with the SRS system within one integrated solution. Reference [23] presents a single-phase transformer system with a tap changer in combination with an AC PWM chopper. Reference [24] describes the idea of a similar system, but the implementation of the CRS was not specified and its power source was also not determined. A medium voltage DT system with a tap changer on the primary side strictly cooperating with a low voltage, three-phase, bidirectional power electronic converter DC-AC acting as a Dynamic Voltage Restorer (DVR) was described in [25]. The disadvantage of solutions [23-24] is the single-phase implementation, and what is more important and also present in [25], is the need to use an additional transformer, incorporated in series with the load. This additional transformer, however, introduces an additional impedance, which changes the tripping conditions of the short-circuit protection infrastructure installed in the PS.

The purpose of this article is to present genuine three-phase AVR concepts with extended voltage regulation capabilities, integrating the SRS and CRS systems, thus realizing the so-called concept of Multi-Zone Voltage Regulation (MZVR).

III. DISTRIBUTION TRANSFORMER WITH MULTI-ZONE VOLTAGE REGULATION

The article concerns a device enabling multi-zone regulation of voltage delivered to consumers in the PS. It is implemented through two cooperating systems: CRS, in form of a Tap-Changing Device (TCD), and SRS, in form of a Power Electronic Converter (PEC) connected to a three-phase DT. Methods of configuration of CRS and SRS systems with a transformer, being exemplary embodiments of the presented MZVR and the objects of research, are presented in Fig. 2 - 5 [26]. The considered MZVR structures are:

- TCD and PEC on SW side (Fig. 2),
- TCD on SW side, PEC on PW side (Fig. 3),
- TCD on PW side, PEC on SW side (Fig. 4),
- TCD and PEC on PW side (Fig. 5).

A common feature of the presented concepts is the integral connection of a three-phase transformer with three three-phase windings: one on the primary side (PW), two on the secondary side (SW1 and SW2) or two on the primary side (PW1 and PW2) and one on the secondary side (SW), wherein one of the two windings (with index 2) from the same side of the transformer is sized for a fraction of the voltage of the second winding (eg 10%) - it is an auxiliary winding (in contrast to the two main windings). One of the main windings has taps (at least three) to change the number of turns and a TCD for switching between taps (eg mechanical, power electronic). This winding has a beginning and end between which there is a rated voltage, at least one tap resulting in a voltage higher than the rated voltage, and at least one tap resulting in a voltage lower than the rated voltage. The winding with the taps together with the TCD form the SRS system.

An integral part of the MZVR device is a three-phase AC/AC bi-directional Power Electronic Converter (PEC) connected to the transformer from the side with two windings. The converter may have a neutral wire led out to the input and output sides, or to one side, or have no neutral

wires at all. The converter input terminals are connected to the auxiliary winding, while the converter output terminals are connected to the ends of the second winding located on the same side of the transformer (the one with higher voltage). PEC enables generating three-phase voltage with adjustable instantaneous value and phase. The maximum instantaneous value of the inverter output voltage is such that it is possible to smoothly regulate the output voltage (on the secondary side of the transformer, which is intended for consumers) in the full range of regulation offered by the device. The PEC converter forms the CRS system and can be implemented both as an AC/DC/AC intermediate system as well as direct, so-called matrix converter.

A characteristic feature of the presented device is the possibility of multi-zone voltage regulation, implemented:

- stepwise, through the TCD tap changer of the transformer winding: SRS system,
- continuously, using the AC/AC power converter: CRS system.

Both voltage regulation methods can be used simultaneously or separately, depending on the desired precision and dynamics of voltage changes.

An exemplary characteristic of output voltage regulation realized by the MZVR built according to this description is shown in Fig. 1. It concerns the configuration presented in Fig. 2. The characteristic shows the output voltage U_o (delivered to the loads) as a function of the voltage generated by the CRS and the state of the TCD of SRS system. The quantities are presented in per-unit system, and are referenced to the nominal voltage of the main secondary winding U_{SW1n} , assuming that the SRS contains three taps: $\{0,9U_{SW1n}; 1,0U_{SW1n}; 1,1U_{SW1n}\}$, while the value of the voltage generated by the converter U_{conv} is in phase or counterphase with the U_{SW} network voltage and varies within the range: $0 - 0,1U_{SW1n}$.

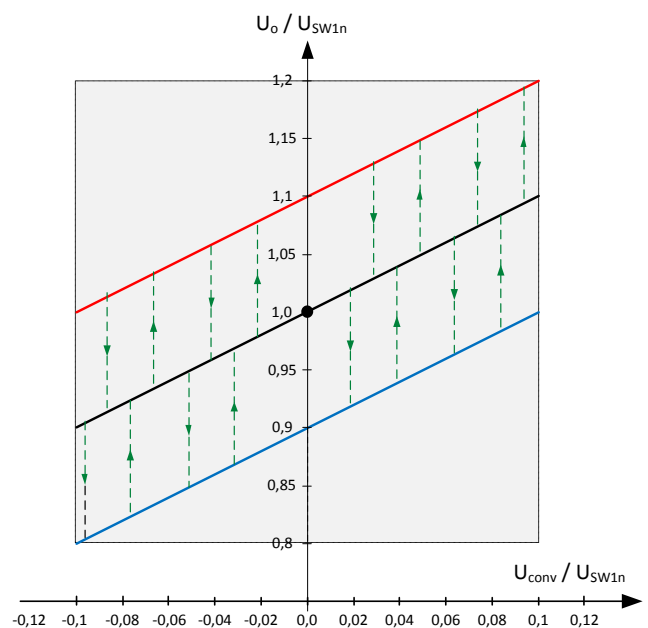

Fig. 1. Exemplary voltage regulation characteristic of the MZVR with 3 taps: $\{0,9U_{SW1n}; 1,0U_{SW1n}; 1,1U_{SW1n}\}$ and maximum converter RMS voltage $0,1U_{SW1n}$.

The solid lines shows the possible operating points of the system. The operating points are made up of three parallel lines in the number of SRS taps. Operating points lying on one straight line reflect the range of continuous voltage regulation using the CRS system. The dashed lines show switching points (operating conditions), in which the SRS system changes the tap, which results in a step change in the output voltage. The arrows indicate the direction of the transition between the characteristics - between which of the SRS terminals the switching operation takes place. Changing the tap and returning to the previous position of the TCD takes place at different values of the output voltage, to prevent undesirable oscillations.

Another integral part of the solution is a special three-phase switch S_{BYP} , enabling shorting of the output terminals of the converter, thus disconnecting the CRS. This feature is important as load current bypassing path in cases of: short circuits at the CRS outputs, PEC failure, or operation of the MZVR system with the voltage regulation function turned off. This increases the reliability of MZVR and increases its efficiency at long work in CRS disabled mode.

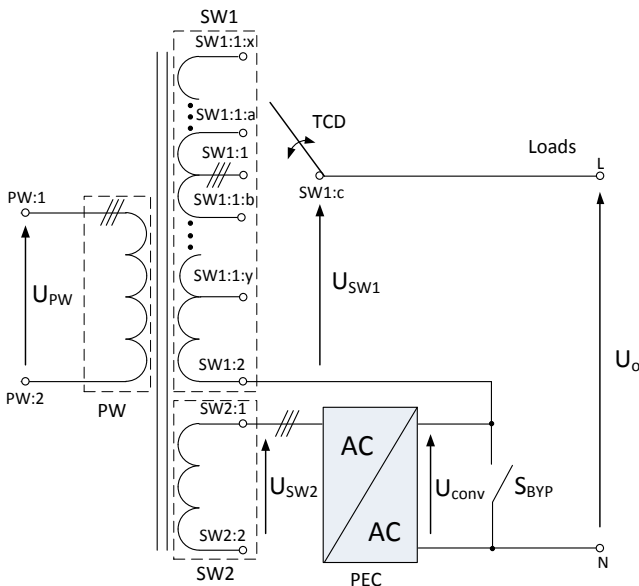

Fig. 2. MZVR block scheme, configuration a).

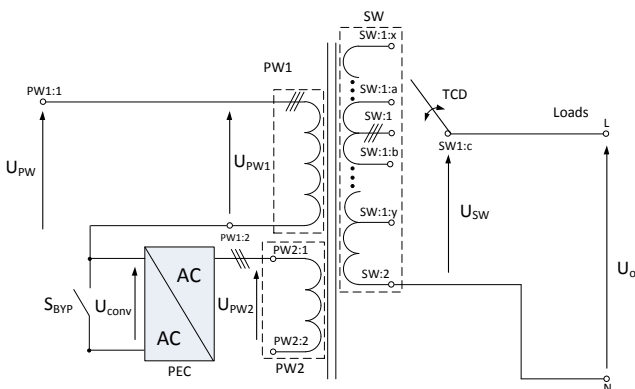

Fig. 3. MZVR block scheme, configuration b).

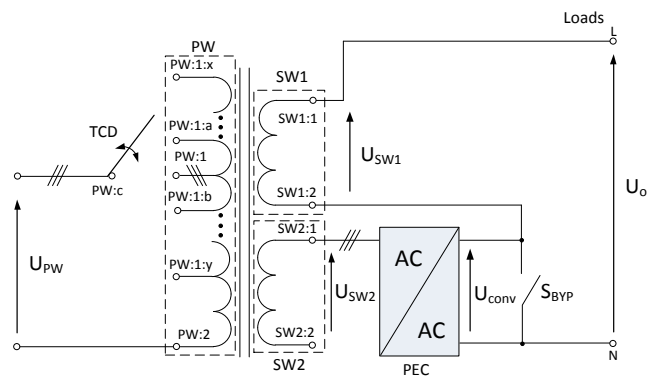

Fig. 4. MZVR block scheme, configuration c).

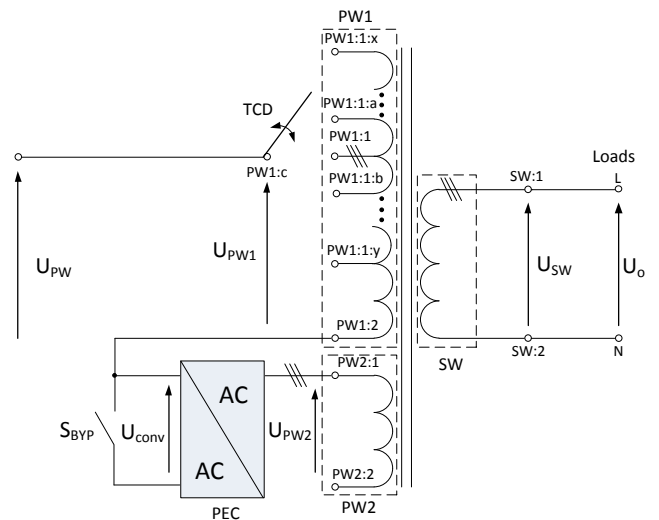

Fig. 5. MZVR block scheme, configuration d).

IV. CRS SYSTEM SIMULATION

For a detailed analysis, the circuits shown in Fig. 2 and Fig. 4 were selected, in which PEC occurs on the secondary side of the transformer. In comparison to the structures in Fig. 3 and Fig. 5, the selected structures have the advantage, that it is possible to compensate for voltage variations resulting from asymmetric loads. The studies started with the CRS system analysis. It was assumed that the TCD system is set at the nominal position and does not change the tap. Hence, the examined structure took the form as in Fig. 6.

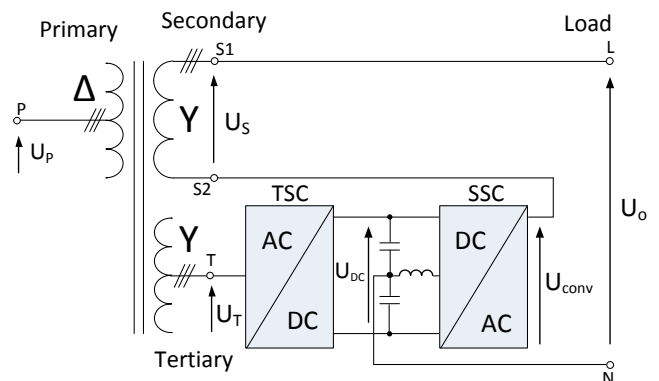

Fig. 6. Simulated CRS structure.

The simulation model was prepared in PSIM v.10 and it contained a 15 kV/400 V/40 V (phase-to-phase) transformer and PEC sized at 600 kVA and 60 kVA respectively. The TSC and SSC parts were both classic two-level voltage source inverters in back-to-back configuration, wherein the SSC converter has a fourth branch for balancing the voltages of the DC link capacitors. Details on the implementation of the simulation model are described in [22].

The system behavior was tested in the situation of rapid changes in the supply voltage on the primary side of the DT. Controlled voltage sources were used, generating 50 Hz symmetrical three-phase sinusoidal voltages: U_{PA} , U_{PB} , U_{PC} . During the simulation, there was a step change in the RMS value U_P of these voltages:

- for ($t \leq 0,1$ s) $U_P = U_{Pn} = 15000$ V;
- for ($0,1$ s $< t \leq 0,2$ s) $U_P = 0,9U_{Pn} = 13500$ V;
- for ($t > 0,2$ s) $U_P = 1,1U_{Pn} = 16500$ V.

The system was supposed to maintain the load voltage on its nominal value, equal 230 V RMS, hence the reference amplitude was: $U_{om_ref} = 325$ V. At the beginning, the current in the Secondary winding does not flow. The load switch was closed at $t = 0,05$ s, and after this event between the terminals L of the Secondary winding and the neutral wire N, the symmetric three-phase load was turned on (series per-phase R_o - L_o connection), which equaled: $R_o = 0,5$ Ω ; $L_o = 0,35$ mH; $\cos\phi_o = 0,98$. The results of the simulation are presented in Fig. 7 – Fig. 13.

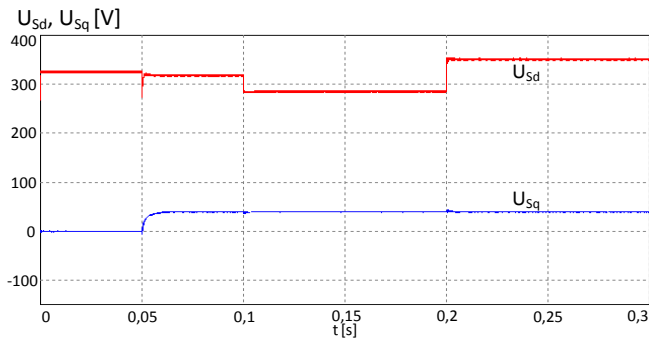

Fig. 7. Secondary winding voltage components in dq frame: U_{Sd} , U_{Sq} .

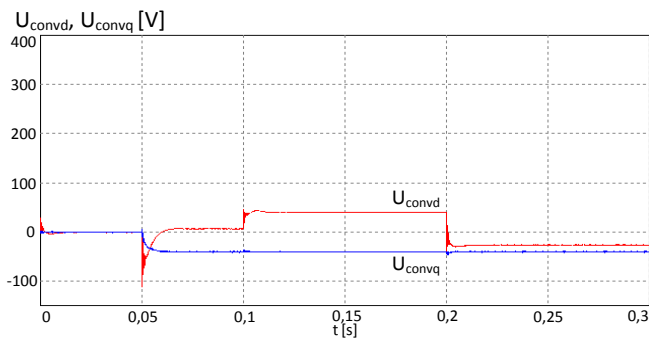

Fig. 8. SSC converter voltage components in dq frame: U_{convd} , U_{convq} .

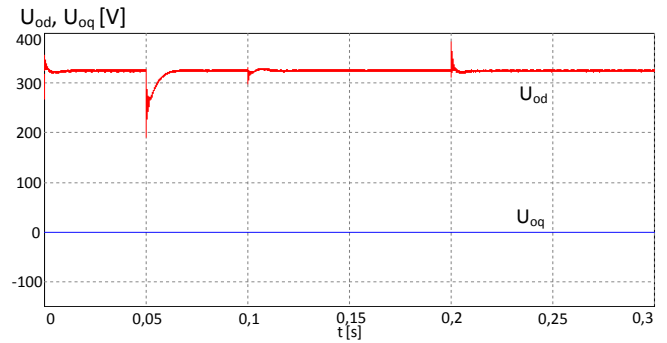

Fig. 9. Load voltage components in dq frame: U_{od} , U_{oq} .

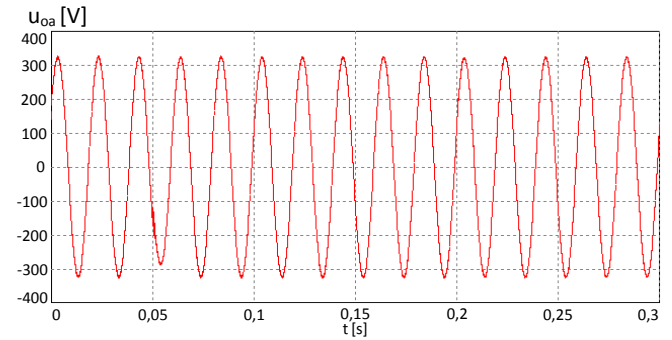

Fig. 10. Load phase a voltage: u_{oa} .

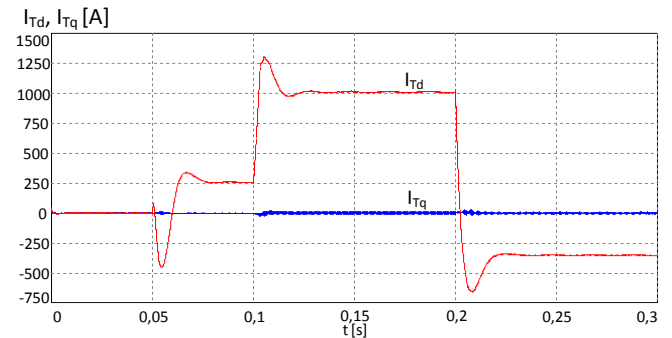

Fig. 11. TSC converter current components in dq frame: I_{Td} , I_{Tq} .

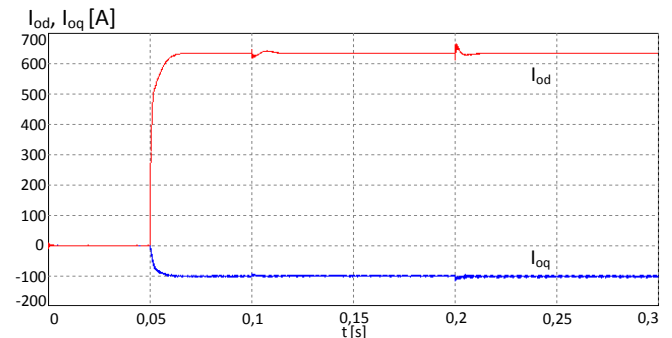

Fig. 12. Load current components in dq frame: I_{od} , I_{oq} .



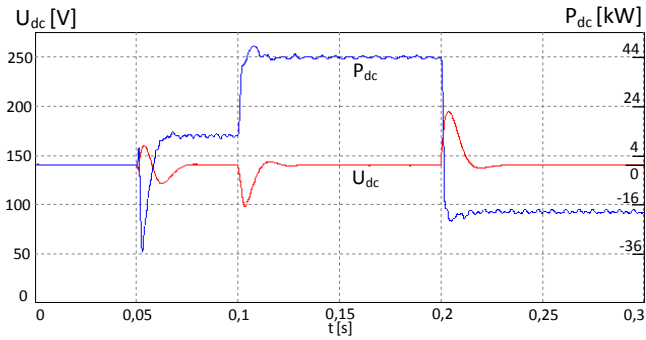

Fig. 13. Voltage U_{dc} and active power P_{dc} of the converter DC link.

V. POSSIBILITIES OF INCREASING THE MZVR POTENTIAL

Considering MZVR systems with an extended range of continuous voltage regulation (or with a higher level of secondary side voltage) or high power versions, the use of a single AC/DC/AC converter, may be very difficult or even impossible at the current state of power electronics technology. In such situations, there is a possibility of converter module connections, as shown in Fig. 14 and Fig. 15.

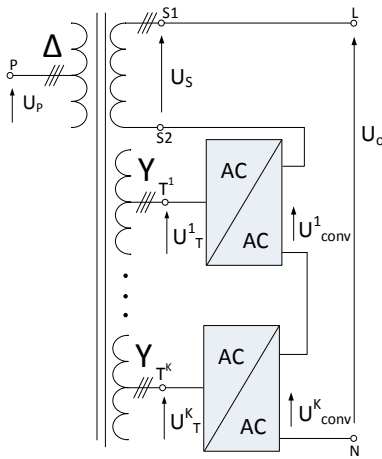

Fig. 14. Connection of PEC converter modules in MZVR systems with an increased range of continuous voltage regulation with multiple auxiliary windings.

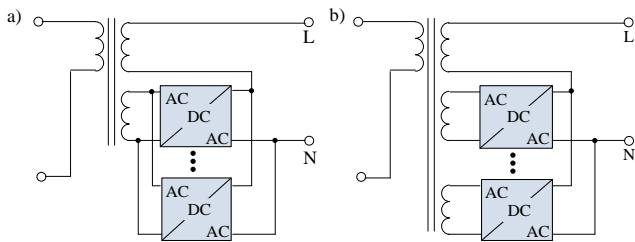

Fig. 15. Connections of PEC converter modules in high power MZVR systems with: a) one auxiliary winding; b) several auxiliary windings.

MZVR systems are also easy to connect in parallel. Because each has a regulation element, the restrictions imposed are not as harsh as for conventional DTs connected in parallel. MZVR systems may vary in both short-circuit and power parameters as well as the rated voltage, within limits, depending on their voltage regulation ranges. The appropriate division of load current is primarily determined by the relation of the additive U_{conv} voltages. In particular,

the condition of even division of the load current between two MZVR systems (Fig. 16):

$$I_{S1} = I_{S2} = \frac{I_0}{2} \quad (1)$$

takes the form of:

$$U_{conv1} - U_{conv2} = I_0 \frac{Z_{S1} - Z_{S2}}{2} + U_{S2} - U_{S1} \quad (2)$$

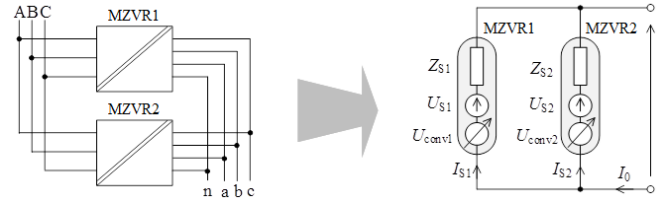

Fig. 16. Parallel connection of MZVR systems.

VI. CONCLUSIONS

In the article four concepts of the MZVR multi-zone voltage regulation system were presented. It is a combination of a distribution transformer with an on-load tap-changer, for step voltage regulation, and a power electronic converter, dimensioned for a fraction of MZVR power, realizing continuous voltage regulation, supplemented by a special switch, the so-called bypass. This allows voltage regulation at high resolution, wide range and with high dynamics and increased reliability.

An important advantage of the device is its high efficiency. With proper design of the SRS system, the losses associated with its operation are negligible. Also, a small share of the power (about 10%) of the CRS part in the overall MZVR power balance, only slightly affects the overall efficiency. The advances in technology already allow the efficiency of converters of 98-99% to be achieved. Therefore, the efficiency of the entire MZVR system approaches the efficiency of the DT itself, within the limits of measurement error. Additionally, in static states, if the conditions and the required dynamics of the system enable the work with active bypass, the efficiency is further improved.

In order to obtain a higher power MZVR device, it is suggested to parallel a greater number of whole MZVR units, which do not require to meet harsh requirements, such as when paralleling classic DTs. However, in order to increase the range of power and continuous voltage regulation within one MZVR, CRS systems can be connected in parallel and in series respectively.

In addition to the wide voltage regulation possibilities, the presented MZVR structures provide additional functionality including, among others: voltage symmetrization, compensation of higher voltage harmonics, power factor correction, or control of energy flow in the case the distribution system has the shape of closed rings. The analysis and presentation of these options did not fall within the scope of this publication.

Thanks to the dynamic and accurate voltage regulation offered by the MZVR, PS operators potentially gain greater control capabilities, which together with the additional functionality of the device, can bring closer the evolution and functioning of the current PS according to the Smart Grid idea.



ACKNOWLEDGMENT

The presented research is conducted as a part of the project: *Hybrid distribution transformer (HDT) as an active element of modern "Smart Grid" systems*, application number: POIR.04.01.02-00-0083/17, funded by the National Centre for Research and Development NCBIR - Poland.

REFERENCES

- [1] R. Strzelecki, G. Benysek, "Power Electronics in Smart Electrical Energy Networks," London: Springer, (2008), pp. 414.
- [2] A. Moreno-Munoz, "Power Quality, Mitigation Technologies in a Distributed Environment," Springer, London, 2007, pp. 222.
- [3] X. She, A. Q. Huang, R. Burgos, "Review of Solid-State Transformer Technologies and Their Application in Power Distribution Systems," IEEE Journal of Emerging and Selected Topics in Power Electronics, 1 (2013), No.3, pp. 186-198.
- [4] I. Roasto, R. Strzelecki, "A simple modular active power electronic transformer," IEEE 23rd International Symposium on Industrial Electronics –(ISIE'14), Istanbul (2014), pp. 1976-1980.
- [5] A. Q. Huang, "Medium-Voltage Solid-State Transformer: Technology for a Smarter and Resilient Grid," IEEE Industrial Electronics Magazine, 10 (2016), No. 3, pp. 29-42.
- [6] K. Mainali, A. Tripathi, S. Madhusoodhanan, A. Kadavelugu, D. Patel, S. Hazra, K. Hatua, S. Bhattacharya, "A Transformerless Intelligent Power Substation," IEEE Power Electronics Magazine, September 2015, pp. 31-43.
- [7] J. Burkard, J. Biela, "Evaluation of topologies and optimal design of a hybrid distribution transformer," Proc of the 17th European Conference on Power Electronics and Applications (EPE'15 ECCE-Europe), Geneva (2015), pp. 1-10.
- [8] "Introducing Minera SGrid, the regulated transformer for smart-grid challenges," Schneider Electric, 2015.
- [9] "On-Load Tap-Changer GRIDCON iTAP. Operating Instructions, 4288748/02 EN," Maschinenfabrik Reinhausen GmbH, 2015.
- [10] К. А. Липковский, "Трансформаторно-ключевые исполнительные структуры преобразователей переменного напряжения," Изд. Наук. думка, Киев, (1983), pp. 214.
- [11] A. Dmowski, "Tyristorowe regulator napięć przemiennych," Wydawnictwa Politechniki Warszawskiej (1979), pp. 113.
- [12] K. Matsuda, K. Horikoshi, T. Seto, O. Iyama, H. Kobayashi, "Development of Automatic Voltage Regulator for Low-Voltage Distribution Systems," Electrical Engineering in Japan, 188 (2014), No.4, pp. 9-19.
- [13] C. Korner, M. Hennig, R. Schmid, K. Handt, "Gaining Experience with a Regulated Distribution Transformer in a Smart Grid Environment," CIRED Workshop, Lisbon 29-30 May, 2012.
- [14] E. C. Aeloiza, P. N. Enjeti, L. A. Moran, L. Pitel, "Next Generation Transformer: To Address Power Quality for Critical Loads," 34th Annual IEEE Power Electronics Specialist Conference PESC '03, Acapulco, June 2003.
- [15] O. M. R. Garcia, A. G. Exposto, "Regulación Continua de la Tensión de Salida en Transformadores Mediante Troceador Reductor," IEEE LATIN AMERICA TRANSACTIONS, VOL. 5, NO. 3, JUNE 2007.
- [16] J. Kaniewski, Z. Fedyczak, M. Łukiewski, "Implementacja trójfazowego transformatora hybrydowego ze sterownikiem matrycowym," Przegląd Elektrotechniczny, R. 86 NR 2/2010, pp. 231-236.
- [17] Z. Fedyczak, R. Strzelecki, „Energoelektroniczne układy sterowania mocą prądu przemiennego”, PAN Komitet Elektrotechniki, Seria Wydawnicza „Postępy napędu elektrycznego”, Wyd. Adam Marszałek, Toruń, 1997.
- [18] J. Burkard, J. Biela, "Protection of hybrid transformers in the distribution grid," Proc. of the 18th European Conference on Power Electronics and Applications (EPE 16, ECCE Europe), Karlsruhe, 2016.
- [19] J. Sastri, S. Bala, "Considerations for the Design of Power Electronic Modules for Hybrid Distribution Transformers," Energy Conversion Congress and Exposition (ECCE), IEEE, September 2013.
- [20] M. A. Radi, M. Darwish, "Var control considerations for the design of hybrid distribution transformers," 11th IET International Conference on AC and DC Power Transmission, Birmingham, February 2015.
- [21] R. P. Kandula, A. Iyer, R. Moghe, J. E. Hernandez, D. Divan, "Power Router for Meshed Systems Based on a Fractionally Rated Back-to-Back Converter," IEEE TRANSACTIONS ON POWER ELECTRONICS, VOL. 29, NO. 10, October 2014, pp. 5172-5180.
- [22] R. Strzelecki, W. Matelski, V. Tomasov, "Hybrid stepless distribution transformer with four-quadrant AC/DC/AC converter at low voltage side - simulation tests," Przegląd Elektrotechniczny, Nr 6/2018, pp. 121-127.
- [23] Jang Do-Hyun, Choe Gyu-Ha, "Step-Up/Down AC Voltage Regulator Using Transformer with Tap Changer and PWM AC Chopper," IEEE Transactions on Industrial Electronics, Vol. 45, No. 6, December 1998, pp. 905-911.
- [24] P. Hammond, "Hybrid Tap-Changing Transformer with Full Range of Control and High Resolution," United States Patent: US 6,472,851 B2, 2002.
- [25] V. Verma, R. Gour, "OLTC-DVR Hybrid for Voltage Regulation and Averting Reverse Power Flow in the Micro-grid with Intermittent Renewable Energy Sources," 2016 IEEE Industrial Electronics and Applications Conference (IEACon) 20-22 November 2016, Kota Kinabalu, 2016.
- [26] R. Strzelecki, K. Waliszewski, W. Matelski, M. Adamowicz, "Transformator rozdzielczy o wielostrefowej regulacji napięcia," Patent Application: P.426308, 2018.