

DYNAMIC STATE ASSESSMENT OF THE WATER TURBINE WITH THE POWER OF 600 kW

Grzegorz ŻYWICA, Paweł BAGIŃSKI, Łukasz BREŃKACZ

Institute of Fluid-Flow Machinery, Polish Academy of Sciences
80-231 Gdansk, Fiszerka 14 str., gzywica@imp.gda.pl

Summary

The article discusses the results of experimental studies to assess the dynamic state of the turbine set with the Kaplan turbine. The dynamic assessment was made on the basis of appropriate standards, based on the measurement results of selected parameters of vibration, which have been measured for several states of the machine load. In addition, we attempted to identify the causes of the increased vibration levels based on the measured vibration spectrum and the temperature distribution on the machine casing. On the basis of analysis results, the tested fluid-flow machine was qualified in the appropriate zone (defining the state of vibration) and identified the source of high levels of vibration.

Keywords: machine's dynamic state, vibrodiagnostics, water turbine, Kaplan turbine.

OCENA STANU DYNAMICZNEGO TURBINY WODNEJ O MOCY 600 kW

Streszczenie

W artykule omówiono wyniki badań eksperymentalnych mających na celu ocenę stanu dynamicznego hydrozespołu z turbiną Kaplana. Oceny stanu dynamicznego dokonano w oparciu o odpowiednie normy, na podstawie wyników pomiarów wybranych wielkości charakterystycznych drgań, które zostały zmierzone dla kilku stanów obciążenia maszyny. Dodatkowo, podjęto próbę wskazania przyczyn podwyższonego poziomu drgań w oparciu o zmierzone widma drgań oraz rozkład temperatury na korpusie maszyny. Na podstawie przeprowadzonych analiz zakwalifikowano badaną maszynę przepływową do odpowiedniej strefy (określającej jej stan drganiowy) oraz wskazano źródło podwyższonego poziomu drgań.

Słowa kluczowe: stan dynamiczny maszyny, wibrodiagnostyka, turbina wodna, turbina Kaplana.

1. INTRODUCTION

During diagnostic tests we can distinguish two main phases (regardless of the type of technical objects); they are the evaluation of the condition and the damage identification. The evaluation of the condition focuses on testing whether the examined object is suitable for use as a whole one, whereas during the damage identification only individual elements of the technical object are checked [1]. Since defects in the different parts of the machine may occur in a similar manner, the task of locating the damage is much more difficult.

The reason for the development of the article was to show the practical possibility of the use of modern diagnostic methods during the tests carried out on the working fluid-flow machine. The usefulness of diagnostic methods developed and used by researchers can be evaluated in the best way by solving unconventional problems in real machines.

1.1. Purpose and scope of research

These studies have been made on demand of a private company – the owner of the hydroelectric

power plant. The company has asked the Institute of Fluid-Flow Machinery PAS in Gdansk, expressing doubts about the quality of the machinery's elements and the proper operation of the turbine set in modernized hydroelectric power plant. After upgrading the power plant the exploited Francis turbine was replaced by a modern Kaplan turbine. It turned out that the work of the new turbine set is accompanied by higher noise and vibration levels than before the replacement.

The aim of this study was to assess the dynamic state of the turbine set (containing Kaplan turbine) in modernized hydroelectric power plant. In the study, the values taken into account were: characteristic parameters of vibration for several states of the machine, vibration spectra and the temperature distribution on the casing. In addition to assessing the condition of the machine, there was also an attempt to identify the causes of high levels of vibration and noise.

1.2. Object of investigation

The tested turbine set with Kaplan turbine has nominal power of 600 kW. The machine works in

the water power plant, which is located next to the cardboard factory, and electricity generated is fed into the national power grid, significantly improving the energy balance of a nearby factory. The dam on the river is shown in Figure 1.



Fig. 1. The dam located next to the hydroelectric power plant



Fig. 2. Tested turbine set in a technical room located in the hydroelectric power plant

Before the experimental study began, operation and maintenance documentation of the turbine set was studied (along with the assembly drawing and technical design of toothed gear). Most important technical data of the machine are included in Tab. 1.

Because of the design solutions, the water turbine's shaft was located under the floor of the technical room (used for the operation of the device). Therefore, there was no direct access to the shaft and its bearings. The upper end of the shaft was supported on the axial spherical roller bearing at the bottom of the wheelcase (that bearing also allowed the transfer of small lateral loads). The toothed gear and the generator were above the floor, as shown in Figure 2. The gear was equipped with a forced oil circulating system. The generator rested on the gear and was fixed by a flange connection.

The power generator's shaft had its own system of bearings and was cooled by a forced air.

Tab. 1. Basic specifications of turbine set.

Water turbine	
Country of origin	Poland
Type of turbine	Kaplan
Year of manufacture	2012
Number of blades	4
Rated speed	147 rpm
Generator	
Country of origin	Poland
Type of generator	Asynchronous, 3-phase
Year of manufacture	2012
Nominal power	600 kW
Rated speed	756 rpm
Mass	4620 kg
Toothed gear	
Country of origin	Poland
Type of gear	Planetary (multiplying)
Year of manufacture	2012
Nominal power	600 kW
Gear ratio	5,11

2. DYNAMIC STATE ASSESSMENT

2.1. Testing method

The study of dynamic state of the machine was carried out according to the standards of ISO10816-1: 1995 [2] and ISO10816-5 [3]. The first of these standards provides general guidance for the measurement and evaluation of mechanical vibration and the other standard sets out detailed recommendations for hydraulic machinery, including water turbines. On the basis of these standards the measurement parameters and measurement nodes were defined. Due to the design solution the turbine set was classified according to [3] to a group number 4, that is, vertical machines sets with lower bearing housings braced against the foundation and upper bearing housings braced against the generator stator only, usually with operational speed of between 60 rpm and 1000 rpm. The scheme of the test machine along with the designation of the measurement nodes, and coordinate system is shown in Figure 3.

The measurements were carried out in three measurement nodes, and each of them was measured in three directions consistent with adopted axes (Fig. 3). This represented a total of nine measurement locations (points). Measurement nodes were located within the upper bearing of the turbine shaft (I) and the lower (II) and the upper (III) bearing of the generator's shaft. Closed machine housings prevented a direct measurement of vibrations on the bearings, and therefore according to the standards, the measurement points were located on steel flanges connected to the bearing support housings. Due to the construction of turbine set, it was

impossible to perform measurements within the lower bearing of the turbine shaft.

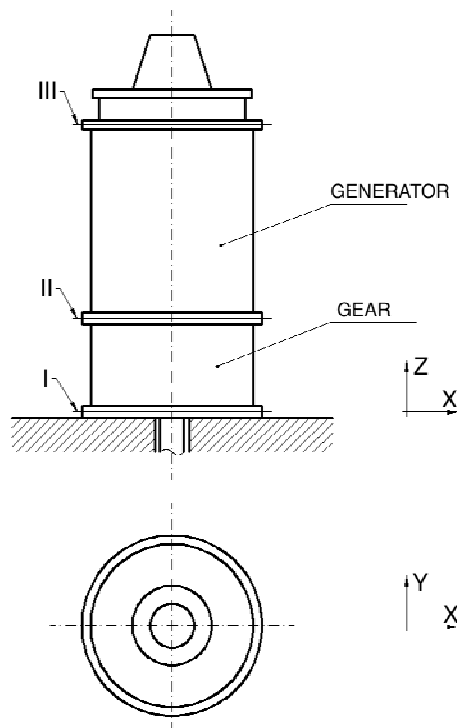

Fig. 3. Scheme of the turbine set with the coordinate system

Based on the standards used [2, 3], the following measuring characteristic values of vibrations were adopted: root mean square of vibration velocity V_{RMS} and peak to peak of vibration displacement A_{P-P} . This was due to the expected wide range of frequencies, in which the harmonic components could occur. For the measurement a mobile device - DIAMOND 401AXT vibration analyzer was used with a connected uniaxial accelerometer. Measurements were carried out in the frequency range 2-1000 Hz with the averaging time equal to 2 seconds. The measurement at each point was performed three times at intervals for approximately 20 seconds, and the final results were determined as the arithmetic mean of three measurements.

Research of the characteristic values of vibrations was carried out for five load states of turbine set. Variable load condition was achieved by adjusting the stator blades of the water turbine and rotor blades in such a way that the level of electric power was 105, 200, 307, 403 and 480 kW. Research for several power levels were designed to evaluate the dynamic state of the machine at different load conditions.

2.2. The results

In the case where both the amplitude and the vibration velocity are recorded, an evaluation of the dynamic state of the machine should be carried out based on the more restrictive requirements [3]. The thresholds values provided for new machines of

group 4 are $A_{P-P} = 30 \mu\text{m}$ and $V_{RMS} = 1,6 \text{ mm/s}$ for the bearings supported within the foundation and the $A_{P-P} = 65 \mu\text{m}$ and $V_{RMS} = 2,5 \text{ mm/s}$ for the bearings above the foundation. In the testing machine, measuring node I was within the foundation, while the nodes II and III were above the foundation.

The measurement results of the root mean square value and the vibration amplitude for the three selected levels of load are presented in Tab. 2-4. The values, which according to the standard ISO10816-5 were above the level of vibration for new objects are highlighted in gray.

Tab. 2. The results of measurements at 105 kW

Node number	Direction X		Direction Y		Direction Z	
	V_{RMS} (mm/s)	A_{P-P} (μm)	V_{RMS} (mm/s)	A_{P-P} (μm)	V_{RMS} (mm/s)	A_{P-P} (μm)
I	0,56	7,66	0,61	7,75	2,76	16,50
II	3,61	24,30	3,47	22,23	1,14	12,60
III	3,25	33,77	3,18	38,73	2,18	15,77

Tab. 3. The results of measurements at 307 kW

Node number	Direction X		Direction Y		Direction Z	
	V_{RMS} (mm/s)	A_{P-P} (μm)	V_{RMS} (mm/s)	A_{P-P} (μm)	V_{RMS} (mm/s)	A_{P-P} (μm)
I	0,38	5,45	0,42	7,04	1,40	13,17
II	2,45	20,53	2,59	20,10	0,88	11,63
III	2,55	34,03	2,83	38,20	2,05	16,30

Tab. 4. The results of measurements at 480 kW

Node number	Direction X		Direction Y		Direction Z	
	V_{RMS} (mm/s)	A_{P-P} (μm)	V_{RMS} (mm/s)	A_{P-P} (μm)	V_{RMS} (mm/s)	A_{P-P} (μm)
I	0,36	5,29	0,41	7,01	1,21	18,47
II	2,26	22,43	2,34	23,63	0,84	13,47
III	2,24	34,43	3,02	39,17	1,92	18,93

According to the criteria of evaluation, in the turbine set there was an excess of threshold level of vibration velocity (provided for the machines which are ready for use) at each load level. Summing up the results of the measurements as a whole, we can say that the worst results were obtained for the measurement node no III in the direction of Y. Rms values of vibration velocity, however, did not exceed the second level of vibrations provided in the standard [3], suitable for machines that can be normally accepted for unrestricted long-term operation. At the same time any of the tested operating conditions have not exceeded the value of the amplitude of vibration provided for the new machines. It can therefore be concluded that the source of elevated levels of vibration were high

frequency vibrations. Therefore, there was also an attempt to identify the direct cause of this situation, as discussed in the next part of the article.

It is also worth noting that the standard used [3] gives the universal values developed on the basis of surveys of many machines. This standard also allows to specify by the manufacturer other, acceptable vibration levels, but it must be due to reasonable cause.

3. THE ASSESSMENT OF THE POSSIBILITY OF DEFECT OCCURRENCE

In order to identify the main sources of vibration in the turbine set, spectral frequency analysis was carried out, in which measurement data were collected at various locations on the machine casing. For the testing machine, over a dozen characteristic frequencies associated with the work of the rotors and toothed gear were appointed (summarized in Tab. 5). In determining these frequencies widely known equations, reported in the literature (in the field of diagnostics of rotating machines) were used (e.g. [4-11]). High levels of vibration at these frequencies could indicate the existence of specific defects or malfunction of some components.

Tab. 5. Characteristic frequencies of tested turbine set

Defect	Frequency (Hz)
Water turbine shaft	
Unbalance	2,45
Misalignment or bend	2,45; 4,9; 7,35
Turbine blade vibrations	9,8
Generator shaft	
Unbalance	12,52
Misalignment or bend	12,52; 25,04; 37,56
Electrical excitation	~50, ~100
Toothed gear	
Frequency of meshing the toothed ring with the planetary cage	271,95; 815,85
Frequency of meshing the toothed ring with the satellite wheels	102,9; 308,7
Frequency of meshing the satellite wheel with the central gear	174,83; 524,48

It should be noted that the vibration components measured on the real object almost never coincide exactly with the theoretically determined frequencies, due to the limited FFT resolution. In addition, in the case of vibrations originating from the toothed gear it comes to frequency modulation of signal, which creates so-called sidebands. On one hand it reduces the transparency of the recorded results, but on the other it helps to identify the frequency of meshing gears.

The two most noted frequency characteristics are shown in Figures 4 and 5. The vibration spectra presented in the following figures were recorded at the highest load of the machine, at which the generator obtained power of 480 kW. In order to facilitate the interpretation of the results in the low frequency range (up to 100 Hz) measured quantity was a vibration amplitude (Fig. 4). At higher frequencies (up to 1600 Hz) measured quantity was a vibration velocity (Fig. 5).

Analyzing the vibration spectrum shown in Figure 4 we can see the dominance of the following components of vibration. At very low frequencies (up to 2 Hz), components were associated with the resonance frequency of the system, which results in the vibration of the whole machine and the foundation. At a frequency of 2.5 Hz the rotational speed component was observed (for the water turbine shaft). At 7.5 Hz we can distinguish the component associated with the shaft misalignment or bend, but its amplitude was lower than the synchronous component. At a frequency of 12.5 Hz synchronous component of generator shaft appeared, and at 25 Hz the increased amplitude of vibration testified about a misalignment or deflection of the shaft. Other components of vibrations in Figure 4 was characterized by a much smaller amplitude. Since in the case of measuring the amplitude $A_{p,p}$ vibration limits for new machines are not exceeded even once, it can be concluded that the observed symptoms of various defects were at an acceptable level. Synchronous vibrations of both shafts were relatively low, and the successive harmonics were reduced almost twice, which meant a slight bend or misalignment.

At higher frequencies, for all the measuring nodes similar vibration spectra were recorded. Characteristics shown in Figure 5 was determined for the measured signal at node II in the direction of the Y axis (on the flange connecting the generator with the transmission gear). The recorded vibration signal allowed to draw the following conclusions. The dominant component (272 Hz frequency) of the resulting characteristics relates to the toothed ring's meshing frequency (it was marked by a blue point and its harmonics by yellow and red points). The origin of the vibrations of toothed gear also testified clear sidebands. Elevated levels of vibration can also be observed in successive harmonic frequencies of toothed ring's meshing: 544, 816, 1088, 1360 Hz. At the frequency of 103 Hz a component occurred resulting from the frequency of meshing the satellite wheels with the toothed ring. Under the frequencies within the range of 170 Hz appeared increased vibration levels that could be associated with the co-operation of the satellite wheels with the central wheel of the planetary gear. Other areas of high vibration levels were difficult to clearly interpret.

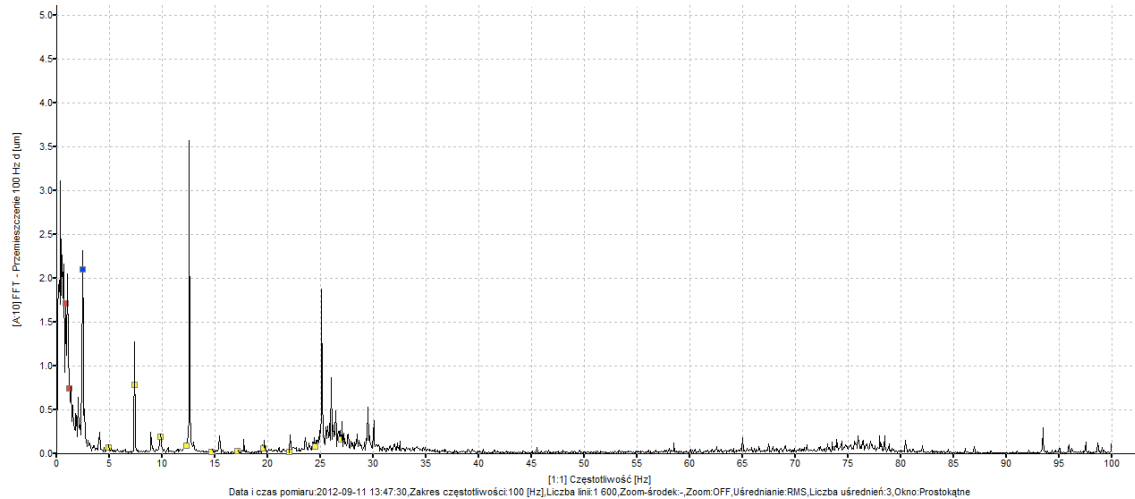

Fig. 4. Frequency spectrum of the vibration amplitudes measured at node III in the direction Y with the selected synchronous frequency of water turbine's shaft at 2.5 Hz (blue dot) and its harmonics (red and yellow dots)

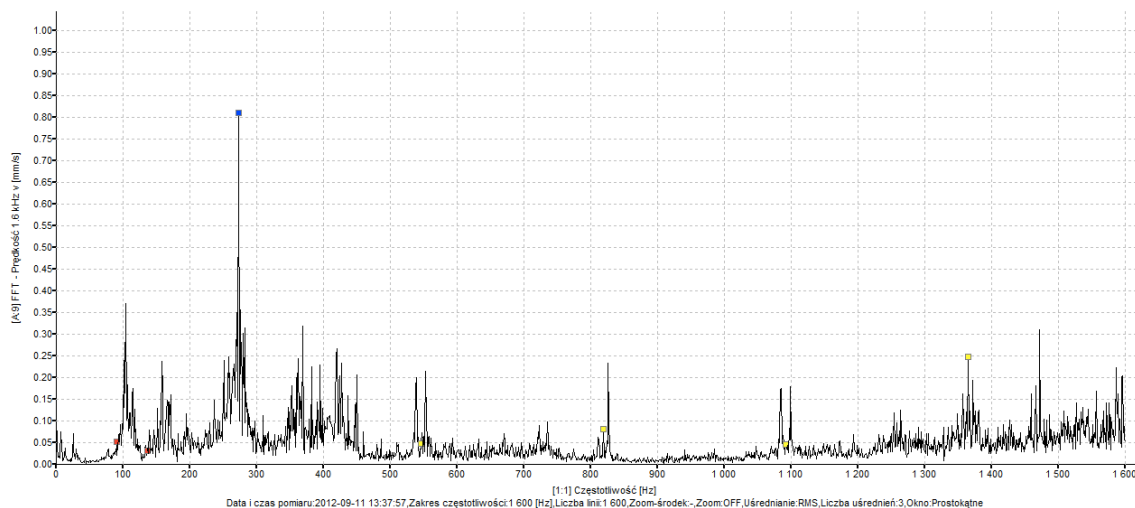

Fig. 5. Frequency spectrum of the vibration velocity measured at measuring node II in the Y direction with the marked frequency of toothed ring meshing with the planetary cage at 272 Hz (blue dot) and its harmonics (red and yellow dots)

The study clearly showed that the cause of elevated levels of rms values of vibration velocity was the operation of planetary gear, and more specifically the lack of smooth cooperation of gears. Since the vibration of the machine was measured on the housing, the registered signal was dominated by vibrations coming from the toothed ring cooperation with the planetary gear. This ring was permanently connected to the gear's body, resulting in the direct transfer of vibrations to the housing.

The analysis conducted of vibrations therefore clearly indicated the source of high level of vibrations, which impacted directly on the acceptable level of vibration (for new objects which are ready for use). The cause of the elevated vibration level was due to the planetary toothed gear. Since this was a new gear, it was unlikely that such quick wearing or damage could have occurred, so this evidenced by low accuracy performance of toothed wheels.

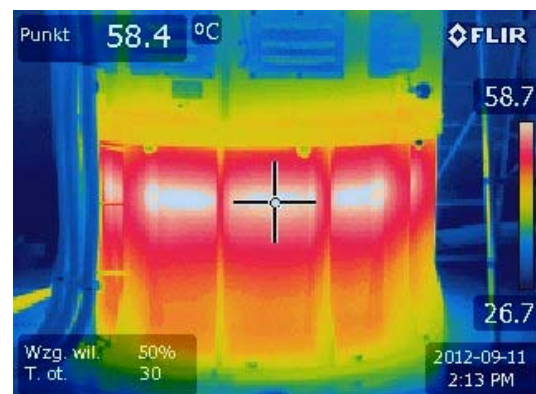

Fig. 6. The temperature distribution on the external surface of the gear housing.

During the assessment of the dynamic state and while searching the defects of the turbine set, supplementary research was conducted in a form of temperature distribution control on the external

surfaces of the housing. Thermovision research of the parts such as bearings and gears allows for the detection of excessive wearing and serious damage, since such defects cause local temperature increase. An infrared camera manufactured by Flir was used in the study (model E50). The study was conducted at the highest load of turbine set (480 kW). One of the thermograms obtained is shown in Figure 6.

In case of the examined water turbine no excessive temperature levels were observed for any of the controlled parts. The highest temperature in the housing of toothed gear was 59.7 °C and it was in the area of connection of toothed ring with the housing (Fig. 6). The temperature on the outer surface of the generator was up to 46.4 °C in the vents, where hot air was removed. Housings design prevented temperature measurement directly on the bearing housing, but the steel elements connected to these retainers had a low temperature. It can be concluded that the control of the temperature distribution showed no symptoms of excessive wearing or damage.

4. CONCLUSIONS

The study of the water turbine with a capacity of 600 kW allowed formulating the following conclusions:

- In the test machine at each of the five tested states the level of RMS value of vibration velocity was exceeded (according to the standard ISO10816-5:2000 for newly commissioned machines),
- The results of measurements allowed to qualify the turbine set for zone B, which according to [3] is the possibility of long-term operation without restrictions,
- The frequency analysis showed that the cause of high levels of vibration was due to the toothed gear operation, and other incompatibilities (e.g. rotors unbalance, bend or misalignment) were at an acceptable level,
- Because studies have shown that the vibration levels were exceeded for the new objects placed in operation, the next inspection of the machine is recommended in the future to detect possible rapid wearing of components (mainly the parts of toothed gear).

REFERENCES

- [1] Niziński S., Michalski R., *Diagnostyka obiektów technicznych*, Biblioteka Problemów Eksploatacji, Radom 2002.
- [2] ISO 10816-1:1995
- [3] ISO 10816-5:2000
- [4] Kiciński J., *Rotor dynamics*, IFFM PAS Publisher, Gdańsk 2006.
- [5] Rao J. S., *Rotor dynamics*, Third Edition, New Age International, New Delhi 2009.

- [6] Barszcz T., *Systemy monitorowania i diagnostyki maszyn*, Wyd. Instytutu Technologii Eksploatacji - PIB, Kraków 2006.
- [7] Barszcz T., Urbanek J., *Monitorowanie i diagnostyka maszyn wirnikowych*, Wyd. Instytutu Technologii Eksploatacji - PIB, Kraków 2008.
- [8] Łączkowski R., *Drgania elementów turbin cieplnych*. WN-T, Warszawa 1974.
- [9] Cempel Cz., *Diagnostyka wibroakustyczna maszyn*, PWN, Warszawa 1989.
- [10] Łazarz B., Wilk A., Madej H., *The diagnosis of planetary gear by means of vibration methods*, Proceed. of the International Congress on Noise Control Engineering, vols 1-3 (1999), pp. 65-70
- [11] Figlus T., Wilk A., Madej H., Łazarz B., *Investigation of gearbox vibroactivity with the use of vibration and acoustic pressure start-up characteristics*, Archive of Mechanical Engineering, Vol. 58, Issue 2 (2011), pp. 209-221.



Grzegorz ŻYWICA, PhD, Eng. Since 2005 has been working at the Institute of Fluid-Flow Machinery PAS in Gdansk, at the Rotor Dynamics and Slide Bearing Department.

In the scientific work he deals with the problems of modelling and computational simulation of the rotating machinery, modal analysis and diagnostics of the machines.



Paweł BAGIŃSKI, M.Sc, Eng., an assistant in the Rotor Dynamics and Slide Bearings Department in the Institute of Fluid-Flow Machinery PAS in Gdansk. Currently a PhD student at Gdansk University of Technology. His main research areas are:

experimental modal analysis, experimental rotor dynamics and numerical modelling of foil bearings.



Łukasz BREŃKACZ, M.Sc, Eng., an assistant in the Rotor Dynamics and Slide Bearings Department in the Institute of Fluid-Flow Machinery PAS in Gdansk. Currently a PhD student at Gdansk University of Technology. His main research areas are:

computational and experimental modal analysis, rotor dynamics and computer aided design.