

Electrodes array for contactless ECG measurement of a bathing person - a sensitivity analysis*

Kamil Osinski¹, Adam Bujnowski¹, Piotr Przystup², and Jerzy Wtorek¹

Abstract—An applicability of a remote (contactless) electrocardiogram (ECG) measurements in a bathtub is presented in the paper. Possibility of ECG measurements in shallowly filled tube with a water was examined. A bathing person was, both, sitting and lying during experiments performed. The problem became non-trivial when the bathing person was moving in reference to a fixed set of electrodes and located at the longer walls of the bathtub. However, the results obtained indicate that the sensitivity of a developed electrode array could enable such measurements. However, a spatial sensitivity distribution determines, both, the recorded ECG signal parameters and quality.

I. INTRODUCTION

A hygiene plays an important role in daily life. Aside providing a life comfort it also could affect the health of people [1]. Despite the fact that showers are the dominant form of hygiene care, the usability of bathtubs is still very high. Among others, this is because modern bathtubs, also called smart bathtubs, in addition to the basic purpose of bathing, are equipped with many additional functionalities, e.g. they maintain the water level and its temperature at given and personalized to specific user values. This is possible due to miniaturization and mass production of cheap sensors and control systems which can be helpful in the system for health monitoring at home (for example [2] and [3]).

However, it should be noted that the bathtub is also a place where dangerous situations could occur during bathing [4]. Due to this, it is very important to monitor the bathing process in terms of the user safety [5]. Various types of technologies could be utilized. However, a remote method, thus contactless, of ECG signal registering seems to be the most common approach. There are many concepts and ideas of contactless recording ECG of the bathing person presented in the literature. In general, there are two approaches. One utilizes a direct contact of measurement electrodes with bath liquid while another approach suggests to use the capacitive electrodes mounted on external side of the bathtub wall [6]. In fact, these two approaches, aside providing different quality of the recorded ECG parameters, determine the way how safety issues are achieved. It is worth noting that presented in the literature systems have a common feature. The electrodes are located in the upper part of the tub, close

*Research supported by The Ella4Life project - Co-funded by the European AAL Joint Programme and partly from Statutory Funds of Faculty of Electronics, Telecommunications and Informatics, GUT.

¹Authors are with Faculty of Electronics, Telecommunications and Informatics, Gdansk University of Technology, Narutowicza 11/12, 80-233 Gdansk, Poland adabu@pg.edu.pl

²Piotr Przystup is with Dynamic Precision Sp.z.o.o., Gdansk, Poland

to the heart. In this case, a large amount of water is always required [7].

Another important factor is to provide a high quality of the recorded ECG independently on the bathing person position in the bathtub. Thus, a configuration of the electrodes array is very important as it decides on a sensitivity distribution. The electrodes array arrangement determines parameters and quality of the electrocardiographic signal [8]. This phenomenon is particularly essential when the ECG is recorded remotely and the monitored person takes a bath. Another important factor is the interferences observed in the measured signal. They are caused by the person movement and capacitive coupling to electrical net. Bathing is rather a dynamic activity and the movement of person - as a consequence the interferences in signal could be also invaluable information. It is because the movement of bathing person is equivalent to normal conditions, i.e. the person is not fainted and normally bathes. The reason for anxiety is the situation when the person's movement disappear and the ECG signal is no more recorded.

Due to the above mentioned arguments, it was proposed to analyze the optimal localization of measuring electrodes in the bathtub. The best localization enables continous ECG recording regardless of the bathing person position.

II. MATERIALS AND METHODS

A. Numerical simulations

For a known geometry, where position of electrodes is well defined it is possible to calculate a spatial sensitivity distribution. The sensitivity is understood as ability to measure ECG of the person sitting or lying in the bathtub in different geometrical relation to the electrodes.

According to the Lead Theory, developed by Helmholtz, the voltage measured using two electrodes could be evaluated using formula (1):

$$V_{LE} = \int_v \mathbf{J} \cdot \mathbf{J}' dv, \quad (1)$$

where: V_{LE} is a voltage measured between electrodes, \mathbf{J} is current density for a hypothetical current applied between electrodes, \mathbf{J}' is the source of the signal, i.e. impressed current in the myocytes. Thus integration is performed over volume containing \mathbf{J}' .

A simplified, however an adequate model was developed (Fig. 1). The model consisted of 12982 tetrahedral elements. A practical implementation of calculations was performed using Comsol package following [9].

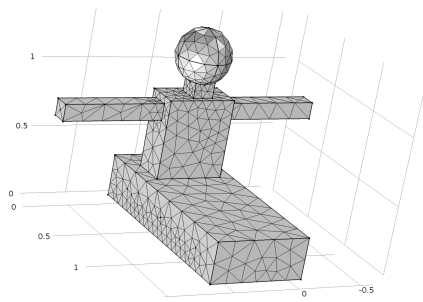

Fig. 1. Simulation mesh for sitting person

Alternative model simulating a person lying in the bathtub and having the thorax immersed in the water was also examined.

B. A measurement setup

A measurement stand consisting of the bathtub with six electrodes attached to the lateral walls, set of amplifiers, analog to digital converters and battery powered laptop was used in the study (Fig. 2). In fact, a whole measurement

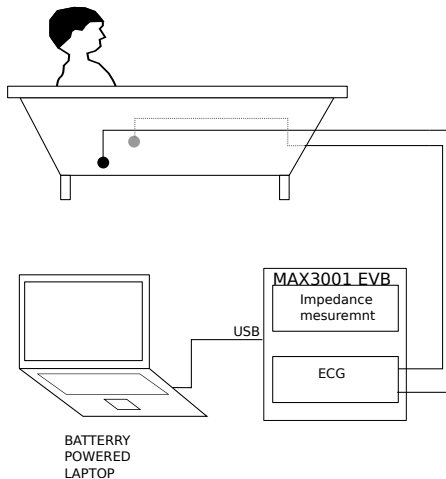

Fig. 2. Block diagram of the measurement setup

system developed was battery-operated in order to fulfill the safety requirements and to reduce 50 Hz interference from the power net. As the analog to digital converters an integrated circuit solution was selected and it was based on a integrated circuit MAX30001 [10]. The MAX30001 EVKIT ([11]) was utilized. It was a measuring platform with dedicated software that allowed to visualize the recorded signals at approx 10s time window. Simultaneously, it allowed to store data in a file. Measurements of the ECG were performed using pairs of electrodes, respectively E1 and B1, E2 and B2, E3 and B3 for two body positions, sitting and lying. A first studied pose was sitting one. The bathing person was sitting and water level barely covered legs (see Fig. 3). Next, the person was lying and water was covering thorax (Fig. 4).

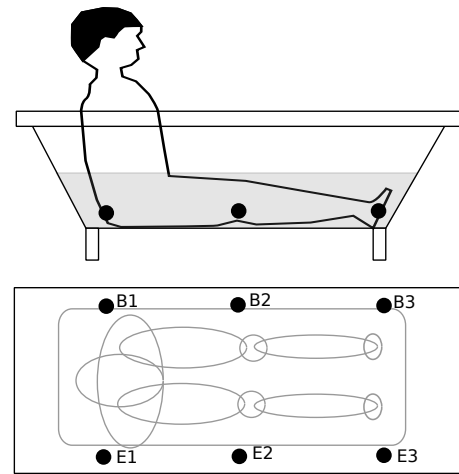

Fig. 3. Electrode positioning, body position and the water level in the bathtub for measurements performed when person was sitting

Acquired data was analyzed using the Octave environment. Where the measurements of the bathing person were made, the electrodes were located at the same height from the bathtub bottom.

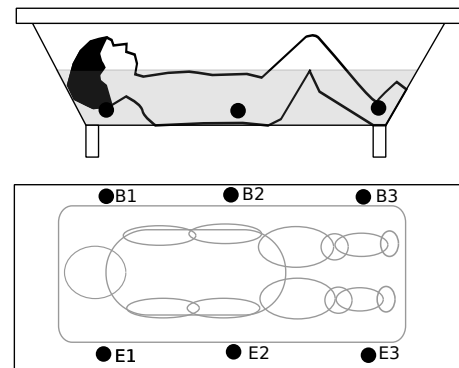

Fig. 4. Electrode positioning, body posture and bathtub infill for measurements in lying position

III. RESULTS

A. Numerical simulations

As the results of simulations sensitivity plots were obtained (Fig. 5) The sensitivity is shown assuming simplified model of cardiac muscle and body geometry. Electrodes were modeled as discrete points on the wall of the bathtub. Six electrodes were located on the side walls of the bathtub.

B. Results of measurements

In a preliminary study single volunteer was performing bath. Results of the ECG measurement of bathing for different electrode setup is shown in Figures 7-10. Electrode's configuration is explained in each figure's caption and refers to setup described in Fig. 4 and Fig. 3.

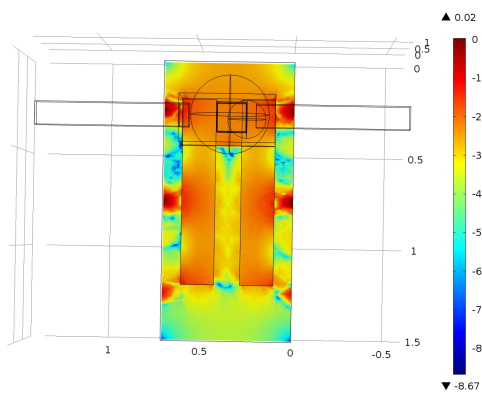

Fig. 5. Sensitivity plot for the model of sitting person

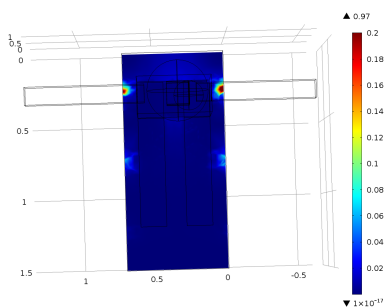

Fig. 6. Signal strength as "seen" on electrodes while person is sitting

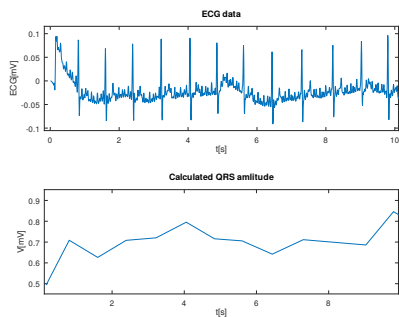

Fig. 7. ECG signal, measured between electrodes E1 and B1, for the person in a sitting position

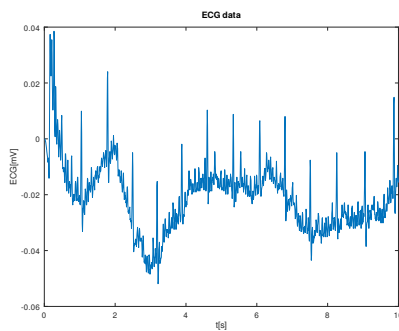

Fig. 8. ECG signal, measured between electrodes E2 and B2, for the person in a sitting position

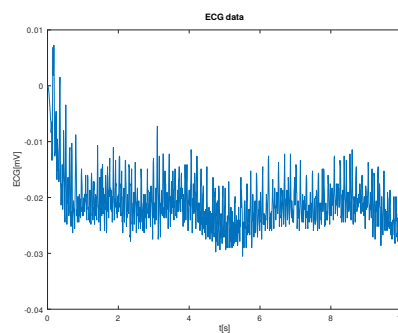

Fig. 9. ECG signal, measured between electrodes E3 and B3, for the person in a sitting position

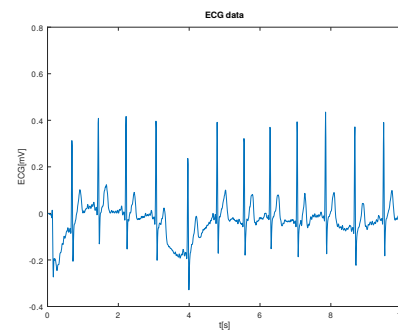

Fig. 10. Received ECG signal for person in lying position. Measured between E1 and B1 for sitting position

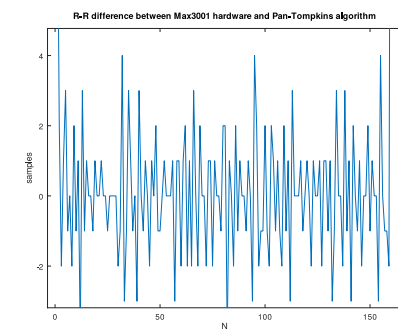

Fig. 11. Detected R-R periods difference between Pan Tompkins and hardware for recording from Fig. 10

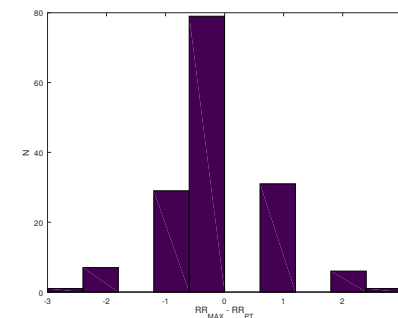

Fig. 12. Correctly detected R waves vs sample shift as comparison between Pan Tompkins algorithm and MAX30001 hardware detector



TABLE I
AN AVERAGE AMPLITUDE OF QRS PERIODS AND ITS VARIANCE FOR
PERSON IN LYING POSITION

electrode configuration	avg(QRS)	var(QRS)
E1 B1	0,90556	0,0027138
E2 B2	0,9125	0,003883

TABLE II
AN AVERAGE AMPLITUDE OF QRS PERIODS AND ITS VARIANCE FOR
PERSON IN SITTING POSITION

electrode configuration	avg(QRS)	var(QRS)
E1 B1	0,76233	0,0063315
E2 B2	0,77295	0,0085525
E3 B3	0,39746	0,02797

IV. DISCUSSION

According to the relationship (1) the sensitivity is proportional to local current density assuming that current hypothetical current flowing between electrodes is 1A (Fig. 6).

In the simulations a simplified model was considered, with rough geometry to preserve numerical complexity. Nevertheless, obtained results are leading to adequate conclusions. The sensitivity function is simply a current density (In Fig. 6). It should be commented that accepting points electrodes in the model led to modification of the sensitivity function. It was because the value of current density was overestimated in relation to real case. Actually, electrodes have a certain area, thus the current density is smaller than for point ones. Nevertheless, the character of the spatial distribution is preserved.

It follows from the study that quality of the measured ECG signals obtained from two leads, i.e. Fig. 7 and Fig. 8 is sufficient. It is possible to gain information on the heart rate and associated information, e.g. rate variability. However, when electrodes are distant from the body trunk the recorded signal is of a much worse quality (Fig. 9). The QRS complexes are not visible.

In present study MAX30001 (Maxim) was used. The Authors were testing performance of self-made systems with analogue amplifier and separate analogue to digital converter in previous study. Results of current solution outperforms self-made solutions.

The integrated circuit MAX30001 had a built in QRS detector. The Authors evaluated its performance versus Pan-Tompkins based algorithm and manual signal analysis. It appeared that the hardware implemented R wave detector was less accurate and was not used for signal analysis. In Fig. 11 and 12 a simplified comparison of the Pan-Tompkins vs hardware based algorithm is shown. It is clear that there are differences between detected episodes for both algorithms. In more detailed signal analysis Pan-Tompkins implementation should be used, while for on-line heart rate analysis.

The aim of this study was to analyze different electrode's configuration for in-bath ECG monitoring. In fact we have

presented results of preliminary results for ECG monitoring in presence of really shallow bathtub infill. Most of previous results presents ECG data with water level reaching the cardiac muscle. We have showed results with water level od about 25 cm which barely covers legs of sitting person. We have recorded ECG signals for person in sitting position using electrodes located at the bottom of the bathtub and compared it to person lying in the bathtub. Signals obtained in latter position have higher amplitude, which also depends on receiving electrode's orientation - see tables I and II.

V. CONCLUSIONS

It follows from the study that three pairs of measuring electrodes appropriately distributed along side wall of tub provide satisfactory measurements. At least two ECG signals of sufficient quality are recorded. The E1 B1 measuring electrodes will provide the best signal quality when the person sits in a bathtub in the orientation shown in Fig 4 and Fig 3. When the person changes his/her position to oposite one then the best signal is observed on the electrodes E3 B3.

REFERENCES

- [1] A. Bujnowski, A. Palinski, and J. Wtorek. An intelligent bathroom. In *2011 Federated Conference on Computer Science and Information Systems (FedCSIS)*, pages 381–386, Sept 2011.
- [2] K. Motoi, S. Kubota, A. Ikarashi, M. Nogawa, S. Tanaka, T. Nemoto, and K. Yamakoshi. Development of a fully automated network system for long-term health-care monitoring at home. *Conf Proc IEEE Eng Med Biol Soc*, pages 1826–1829, 2007.
- [3] Seung-Jin Jang, Joo-Hwan Lee, Jung-Hoon Lee, Sung-Bin Park, Sung-Oh Hwang, Hyoung-Ro Yoon, and Young-Ro Yoon. Ubiquitous home healthcare management system with early warning reporting. *International Conference on Convergence Information Technology (ICCIT 2007)*, 2007.
- [4] T. Chibaa, M. Yamauchia, N. Nishidaa, T. Kanekob, K. Yoshizakib, and N. Yoshiok. Risk factors of sudden death in the japanese hot bath in the senior population. *Forensic Science International 149*, pages 151–158, 2005.
- [5] R. Ogawa and T. Togawa. Attempts at monitoring health status in the home. In *1st Annual International IEEE-EMBS Special Topic Conference on Microtechnologies in Medicine and Biology. Proceedings (Cat. No.00EX451)*, pages 552–556, 2000.
- [6] Motoi Kosuke, Yamakoshi Yasuhiro, Yamakoshi Takehiro, Sakai Hiroaki, Tanaka Naoto, and Yamakoshi Ken-ichi. Measurement of electrocardiograms in a bath through tap water utilizing capacitive coupling electrodes placed outside the bathtub wall. *BioMedical Engineering OnLine*, 16(1):12, Jan 2017.
- [7] Kazuki Nakajima, Katsuhisa Sekine, Katsuya Yamazaki, Atsushi Tampo, Yuuichirou Omote, Hiroshi Fukunaga, Yasuko Yagi, Kyoji Ishizu, Masanori Nakajima, Kazuyuki Tobe, Masashi Kobayashi, and Kazuo Sasaki. Detection of respiratory waveforms using non-contact electrodes during bathing. *32nd Annual International Conference of the IEEE EMBS*, pages 911–914, 2010.
- [8] Jaakko Malmivuo and Robert Plonsey. *Bioelectromagnetism - Principles and Applications of Bioelectric and Biomagnetic Fields*. 01 1995.
- [9] Debarati Mishra, Shalivahan, and Abir Banerjee. Sensitivity plots using comsol 5.1 multiphysics; a tool for optimizing geophysical field survey. In *Excerpt from the Proceedings of the 2015 COMSOL Conference in Pune, 2015*.
- [10] Maxim. Ultra-low-power, single-channel integrated biopotential (ecg, r-to-r, and pace detection) and bioimpedance (bioz) afe, 2018.
- [11] Emre Eken. Max30001-max32630fthtr ecg evaluation system, 2018.

