

Wojciech Litwin

ORCID 0000-0002-1787-229X

Gdansk University of Technology; Faculty of Ocean Engineering and Ship Technology

ul. Narutowicza 11/12; 80-233 Gdansk; Poland

wlitwin@pg.gda.pl

Experimental research on marine oil lubricated stern tube bearing

Abstract

Bearings of propeller shafts are very crucial elements of the propulsion system of each of the ships. The safety of shipping depends on their durability and reliability. The new legal restrictions mean that today we are looking for environmentally friendly solutions. That is why water-lubricated bearings are becoming more and more popular. So, will oil lubricated shaft bearings belong to the past?

The bearing with a white metal bushing lubricated with mineral oil, which was subjected to experimental tests has a number of advantages. First of all, it works in the area of full fluid friction and in typical shipbuilding conditions it has a significant excess of hydrodynamic load capacity.

Therefore, replacing mineral oil with an environmentally friendly lubricant with a similar viscosity seems to be a promising solution. Motion resistance larger than in water lubricated bearings compensates for the reliability and durability of this solution.

Keywords: hydrodynamic lubrication, journal bearing, marine bearing, oil lubrication, stern tube bearing

1. Introduction

Marine main shafts bearings are very crucial elements of the propulsion system of each of the ships. The safety of shipping depends on their durability and reliability. Despite the fact that the engineers today have a lot of knowledge and are able to design a correctly operating sliding bearing, every year failures or premature wear of the sliding couples are reported. Common causes of failure are:

- errors in assembly resulting stress concentration caused mostly by the misalignment of the bushing and the shaft (1)(2) (3),
- unfavorable bearing interspace geometry, especially lubrication grooves distributed around the perimeter (4)(5),

- excessive bearing clearance and other bushing shape errors due to assembly by means of a thermo compression method (bush is cooled before installation, for most of polymers thermal expansion coefficient is high so it helps to shrink bush and install it easy in housing),
- improper sliding couple or hard operation conditions (6)(7),
- improper lubrication, not sufficient flow of the medium causing overheating of the sliding couple (8), solid particles in the lubricating liquid (9)(10), corrosion (11), etc.

It is worth adding that a classification society monitor over each of the operated ships. It supervises the ship from the moment when the design of the unit is created, throughout the entire period of operation, making systematic inspections until the unit is withdrawn from service. Supervision of highly qualified specialists increases the chances of long and trouble-free operation of the ship. On the other hand, fierce competition between ship owners means that when designing a new ship or renovating an older unit, the cheapest solution, not always the most durable or reliable one is chosen.

In recent years, environmental protection has become one of the most important issues (12). This is one of the reasons why water lubricated bearings are becoming more and more popular. They have recently been subjected to comprehensive experimental tests in various centers around the world. The tribological properties of various sliding couples, properties of bearings during operation under mixed or full fluid friction conditions are tested. The durability of bearings under severe operating conditions with limited cooling is assessed, when the shaft axis is not alignment in the bushing (2) or during lubrication with liquids containing particulate contaminants (9)(10).

In addition to numerous advantages, water lubricated bearings have quite severe limitations, which means that oil lubricated bearings are still used on parts of newly built ships with transmission through the shaft line. Former tests on sliding bearings lubricated with water, the results of which were published in the literature, have identified the most important limitations and risks for some of the currently used materials (13) and the geometries of the bushings, such as:

- limited hydrodynamic load capacity (5),
- considerable resistance to motion during start-ups and during operation in the mixed friction area (14),
- occurrence of stick p phenomena (15),
- sensitivity to non-coaxial position of the shaft, especially for stiffer bushing materials (16),
- sensitivity to work temperature (8),
- limited durability of bearings installed in open systems without sealings lubricated with water containing particulate contaminants (17).

The analysis of solutions used on newly built ships shows that oil lubricated bearings, despite the high price, are still willingly used because they have a whole range of advantages. The use of seals



and operation of the propeller shaft in the lubricating oil is an excellent protection against aggressive corrosive environments such as sea water. Moreover, no corrosion-resistant but high-strength grades of alloy steels can be used for making shafts. This reduces the dimensions of the shaft and consequently reduces the unit's construction costs. Oil lubricated bearings usually work in a wide area of full fluid friction and thicker than in the water lubricated bearing, lubrication films allow to limit the negative impact of minor misalignment of the shaft and bushing axis. It should be added that the coaxial error of the shaft and bushing is practically always present, although every effort is made to make it as small as possible. It is usually the result of technological problems related to the construction and assembly of large-size elements and of deformation of the ship's hull during operation in various loading conditions and in changing weather conditions.

The purpose of the planned and conducted tests was to get a better knowledge on the most heavily loaded stern tube bearing lubricated with oil with bushing made of white metal. The measurements were carried out in a wide range of working conditions that may occur during operation. As a result, it becomes possible to compare the properties of an oil lubricated bearing with previously tested bearings lubricated with water of the same dimensions under the same operating conditions (4)(18). It is also important to note that currently environmentally friendly oils based on esters, glycol or even water are developed, which could replace petroleum oils (19)(20). Therefore, it is anticipated that marine bearings lubricated with liquids with viscosity definitely higher than water will still be produced and exploited. The shipowners of some ships, especially special units, are willing to pay the high costs of such a solution to ensure high operational safety and reliability.

Therefore, in order to gain new knowledge in the field of tribology, it was decided to use a test stand, which in the past was used to test water lubricated sliding bearings for testing oil lubricated bearings.

2. Experimental testing

A modernized test stand shown in Fig. 1 was used for the tests.



Fig. 1. Test stand;

The test stand for detailed examination of a single bearing has a construction, which is typical for these units (14)(21)(22)(23). The main shaft of the test stand made of carbon steel is supported by two rolling bearings with the tested bearing unit in between. (Fig. 2). An electric motor with a reduction gear was used for the drive. The motor is equipped with speed control system. It has a starting torque of about 160 Nm. The bushing with a sliding layer made of white metal housed in a steel sleeve (2) was mounted on the shaft (1). The oil is supplied through two longitudinal grooves in the horizontal plane of the bearing (Fig. 2). The oil flows out of the bearing on both sides to the covers (3). The tested bearing unit is closed on both sides with the covers in which the sealing rings (3) are mounted. The load is exerted by a hydraulic cylinder via a hydrostatic bearing (4). The place where the hydrostatic film is made is shown in the illustration below (Fig. 2). Separation of the system of exerting the load from the bushing unit through a thin layer of oil under pressure enabled precise measurement of motion resistance and calculation of the coefficient of friction. Unfortunately, this way of supporting also has a disadvantage. During the tests there is no control on the position of the axis of the bushing with relation to the axis of the shaft. The bearing behaves similar to a self-aligning bearing. In the described case, thanks to the high precision of the shaft and the bushing and the symmetric oil supply through the longitudinal groove, there was only a barely noticeable axis skewing.

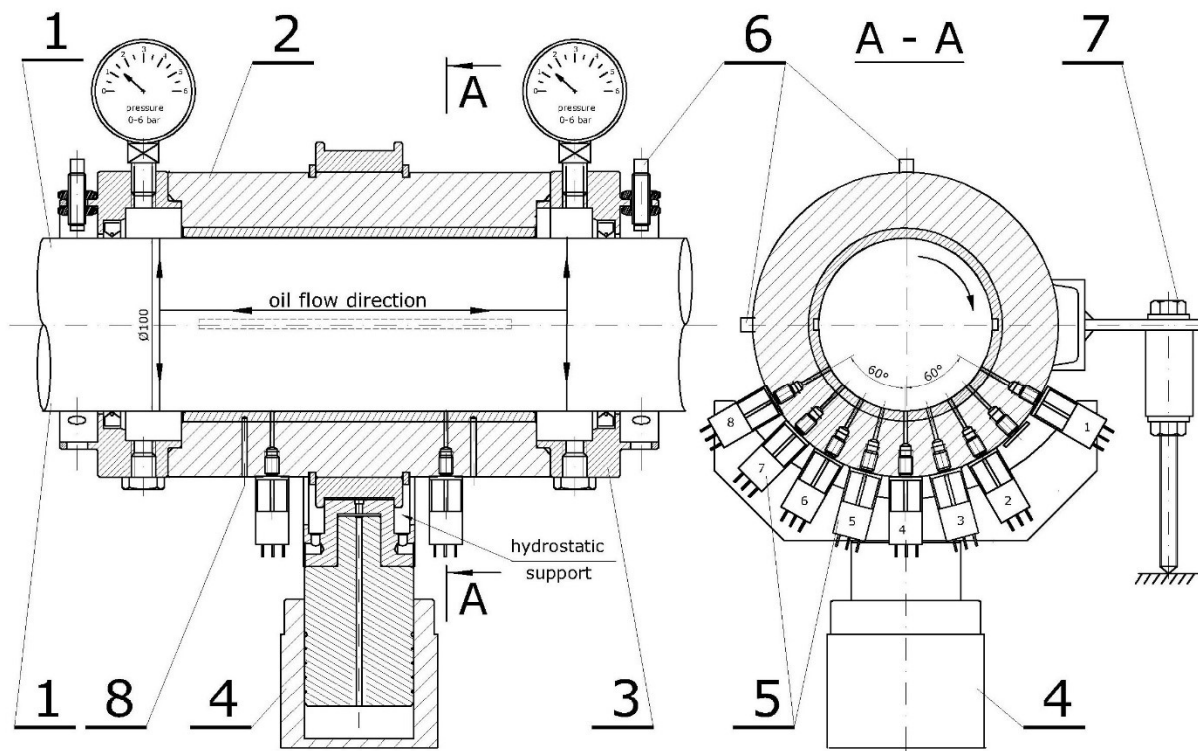

Fig. 2. The tested bearing unit; 1- main shaft, 2- tested bushing unit, 3- covers with seals, 4 - load exertion system, 5- pressure sensors, 6- contactless proximity probes, 7- friction force sensor, 8 - temperature sensors installed in the bushing sliding layer

The stand is equipped with two pump units. One using hydraulic oil feeds the load exerting cylinder (4) and the hydrostatic bearing through which the tested bearing is loaded. The radial load value of the tested bearing is controlled by control of a specific supply pressure by overflow valve. The second hydraulic unit is used to supply the lubricating oil to the tested bearing. The output of the feed pump and the oil supply pressure can be adjusted. The lubrication system is adapted to mineral oils, synthetic oils and lubricants of similar viscosity based on esters, glycol, etc.

Thanks to the load exerted by the hydrostatic bearing, it is possible on the test stand to accurately record the motion resistance. Making accurate measurements of the friction force allows to calculate the coefficient of friction. A small measurement error results from the fact that the friction force of the bearing and of two sealing rings is registered simultaneously. This is quite a typical problem and it also appears in other similar test stands (22)(23). However, it is believed that the coefficients of friction of the rings are minimal, and to further reduce them, the springs pressing the sealing lip were disassembled.

On the stand, it is possible to measure the distribution of pressure in the lubrication film through sensors installed in the bearing bush. In a typical case, sixteen pressure sensors are installed in two groups of eight. The arrangement of the sensors shown in the figure is not accidental. The larger

distance between sensor 1 and 2 was intentionally provided. This was due to the need of measurements made in the zone where the hydrodynamic pressure drops quickly and cavitation can occur.

The stand is equipped with two pairs of proximity probes, contactless sensors on both sides of the tested bearing (fig. 3 part number 6) enabling non-contact measurement of the distance between the shaft and the bushing (6). The use of carbon steel shaft during testing, which does not contain strong ferromagnetic nickel and chromium like stainless steel necessary for water lubricated bearings, made it easier to measure distances and increase the measurement precision. The possibility of rotating the bearing bush loaded by the cylinder on the fixed shaft (after disassembling the friction force sensor) enables the determination of the boundary positions of the shaft in the bushing so that it is possible to apply the clearance circle to the shaft's orbit diagrams (Fig. 3). This is a very valuable feature of the test stand that allows the assessment of the thickness of the lubricating film during the analysis of results. In the graphs below (Fig. 3) there are two centric circles, which define the contact zone between the shaft and the bushing - dependent on the radial load value and result from the elastic deflection of the bushing and shaft as a result of specific pressure (from 0.2 to 0.8 MPa). During bearing tests, when measured shaft orbits are placed inside the clearance wheels, it is possible to evaluate the approximate thickness of the lubricating film. It is also worth noting that the clearance wheels on both sides have the same dimension and the shape errors are negligibly small. These measurements confirmed that the diameters of shaft journal and bush are correct and allowed to calculate a diameter clearance amounting to 0.27 mm. Measurements carried out at the temperature of 20 and 50 degrees have shown that the bearing clearance changes slightly and this change can be omitted by analyzing the measurement results. Numerous tests of water lubricated sliding bearings carried out in the past have each shown significant errors in the shape of clearance circles (4)(18). This was due to difficulties in the precise machining of the polymeric bushing. Such a problem do not take place in bearing with white metal bush.

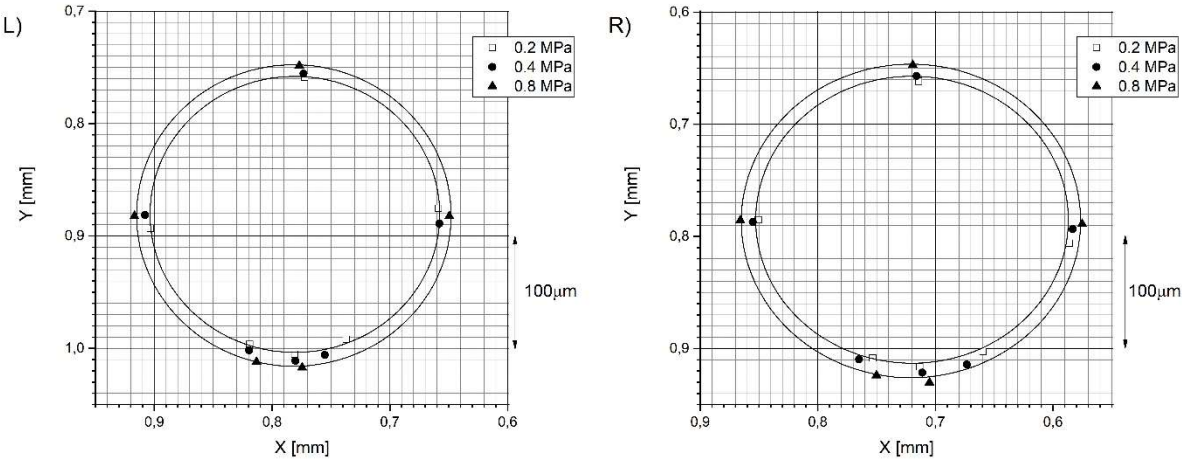

Fig. 3. Verification of the position and size of the clearance circle of the tested bearing, the contact points between shaft and bush were presented; left bearing side (L) and right side (R)

The stand has five temperature sensors - thermocouples. During the tests, the supply and outflow of lubrication oil temperature and the temperature of the bush are measured. Two sensors are installed in the sliding layer (Fig. 2) and one on the surface of the bushing. The tested bearing, lubricant and operation conditions were presented below in the table 1.

Table 1. Data of bearing, working conditions and details of measurement sensors

1	Diameter of the shaft / length of the bushing	100 mm / 200 mm
2	Bearing clearance measured at the temperature of 20 degrees	0,27 mm
3	Rotational speed of the shaft	0 – 11 rev/s
4	Radial load [N] / specific pressure [MPa]	4kN, 8kN, 12kN, 16kN, 20kN / 0.2MPa, 0.4MPa, 0.6MPa, 0.8MPa, 1MPa
5	Lubricating oil - mineral, typical for the lubrication of low-speed internal combustion engines and sliding bearings of the shaft line produced by several reputable manufacturers, SAE 30 often described as type 3005. Viscosity at 40 degrees Celsius	105 cSt
6	Bearing bush material – white metal SnSb8Cu4Cd (Sb 7÷8%, Cu 3÷4%, Cd 0.8÷1.2%, Pb 0.35%, As 0.5%, Sn 85.45÷88.25)	
7	Pressure strain gauge sensors (16 pcs.), range 0÷6 MPa, accuracy ±0.3% FS (full scale)	
8	Friction torque measurements – strain gauge sensor with amplifier, range 0-100N, accuracy ±0.5% FS	
9	Distance touchless measurements – proximity probes – with analog output, accuracy ±1% FS	
10	Temperature measurements – K thermocouples, accuracy 1% FS	
11	A/D data acquisition system, pc computer and A/D card	

3. Test results

Before each test, the stand and lubricating oil was warmed up. This was carried out by starting-up the stand (initial stable temperature of 20 degrees Celsius of the entire system), which worked for 90 minutes with the shaft speed of 11 rev/s. The load exerted in the bearing was 0.6 MPa. In the first phase of the work, for about 15 minutes the oil in the tank was heated using an electric heater. After about 90 minutes, the temperature of the oil and the bearing bush stabilizes. Fig. 4. Therefore, as the operating conditions for the bearing installed on the test stand, the following has been assumed:

- Supply oil temperature 44 degrees Celsius
- Temperature of the bearing bush 55 degrees Celsius.

As predicted, the resistance of movement during start-up when the oil and bearing temperature is 20 degree coefficient of friction is much higher (0.032) than after the operating temperature is reached (0.01). This is mainly due to the viscosity of the oil, which decreases with increasing operating temperature. It is worth adding that the procedure of preheating oil is a common practice on ships. As

a result, the resistance of movement of the shaft unit can be reduced already in the initial phase of operation after the start-up of the drive system.

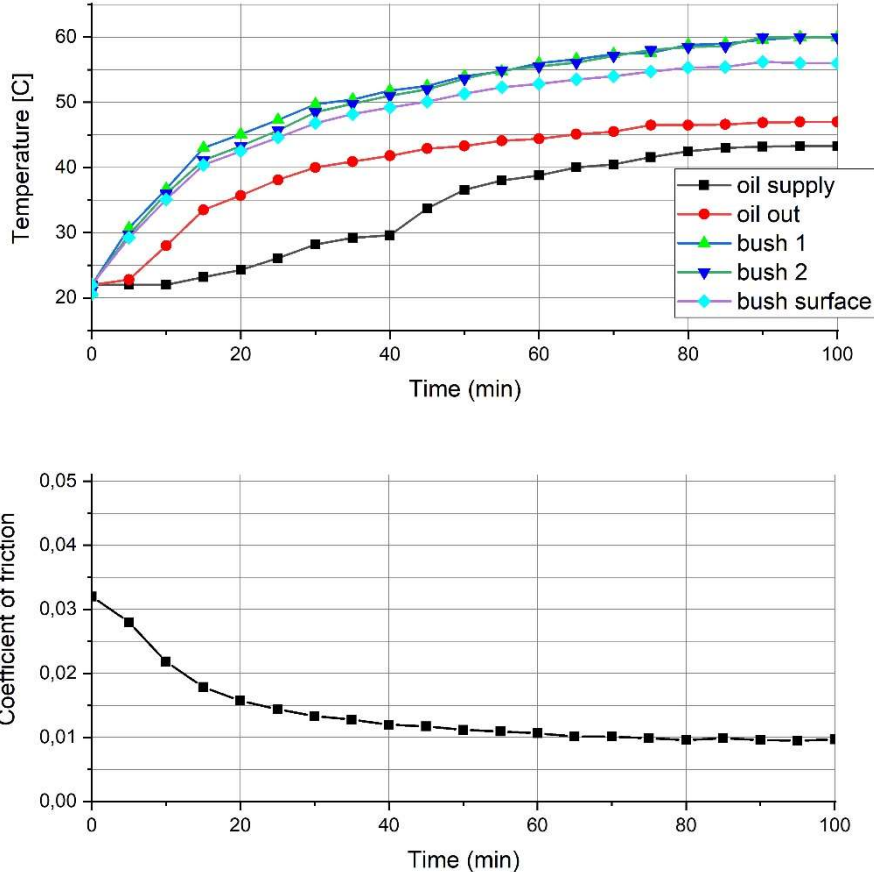

Fig. 4. Temperature and friction coefficient graphs during warming up of the stand; load 20 kN (specific pressure 1 MPa), shaft speed 11rev/s

The measurements carried out showed that the bearing works in a wide range of liquid friction. This is indicated by the measured low resistance of movement (Fig. 5), distribution of hydrodynamic pressure in the lubrication film (Fig. 6) and the shaft orbits (Fig. 7).

The characteristics of the coefficient of friction as a function of rotational speed and load indicate that during the start-up there is a significant reduction in the resistance of movement. The static friction coefficient ranged from 0.12 to 0.15. The static friction was acquired during slow start-up to the speed of 1 rev/s with sampling frequency 1 kHz. Similar values of coefficient of friction were acquired by others researchers (24). There was no increase in motion resistance resulting from longer standstill of the shaft which is typical for bearings with plastic bushings when there is a stick - slip phenomenon. The coefficient of friction decrease in the resistance of motion for each of the speed points and slightly

increase with growing speed, that are a typical phenomena for a bearing operating in the area of hydrodynamic lubrication (Figure 5). It results from the fact that the increase in load entails an decreasing of film thickness, which in turn causes the temperature in the lubricating film to rise as an effect of growing shearing stress in thin lubricant layer, causing reduces the resistance of motion. In optimal conditions, when the bearing is loaded with specific pressures from 0.4 to 0.8 MPa in typical for the operation of small ships shaft speed with a diameter of 100 mm ranging from 7 to 11 rev/s, the coefficient of friction is from about 0.01 to 0.055. It is worth remembering that this value shows the total resistance of bearing and two sealing rings.

The tested bearing with a diameter of 100 mm could be used in the propulsion system of a small ship with a propulsion power of around 200 kW. The calculated frictional power in the analyzed case when the coefficient of friction is 0.02 reaches even 1.1 kW. It would be about 0.5% of the power of the drive system, which is a small value compared to the other energy losses of the drive system components. The efficiency of the internal combustion engine usually does not exceed 50% (25) and the efficiency of the propeller does not exceed 60 % (26)(27).

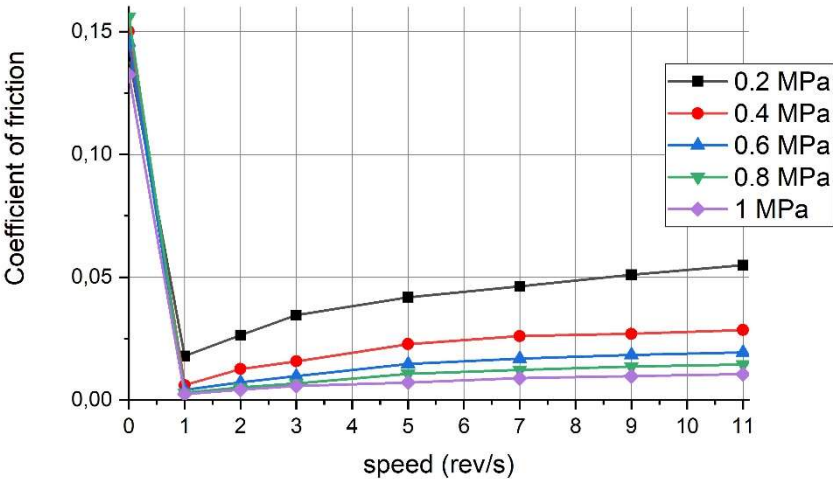

Fig. 5. Measured resistance of motion in the tested bearing

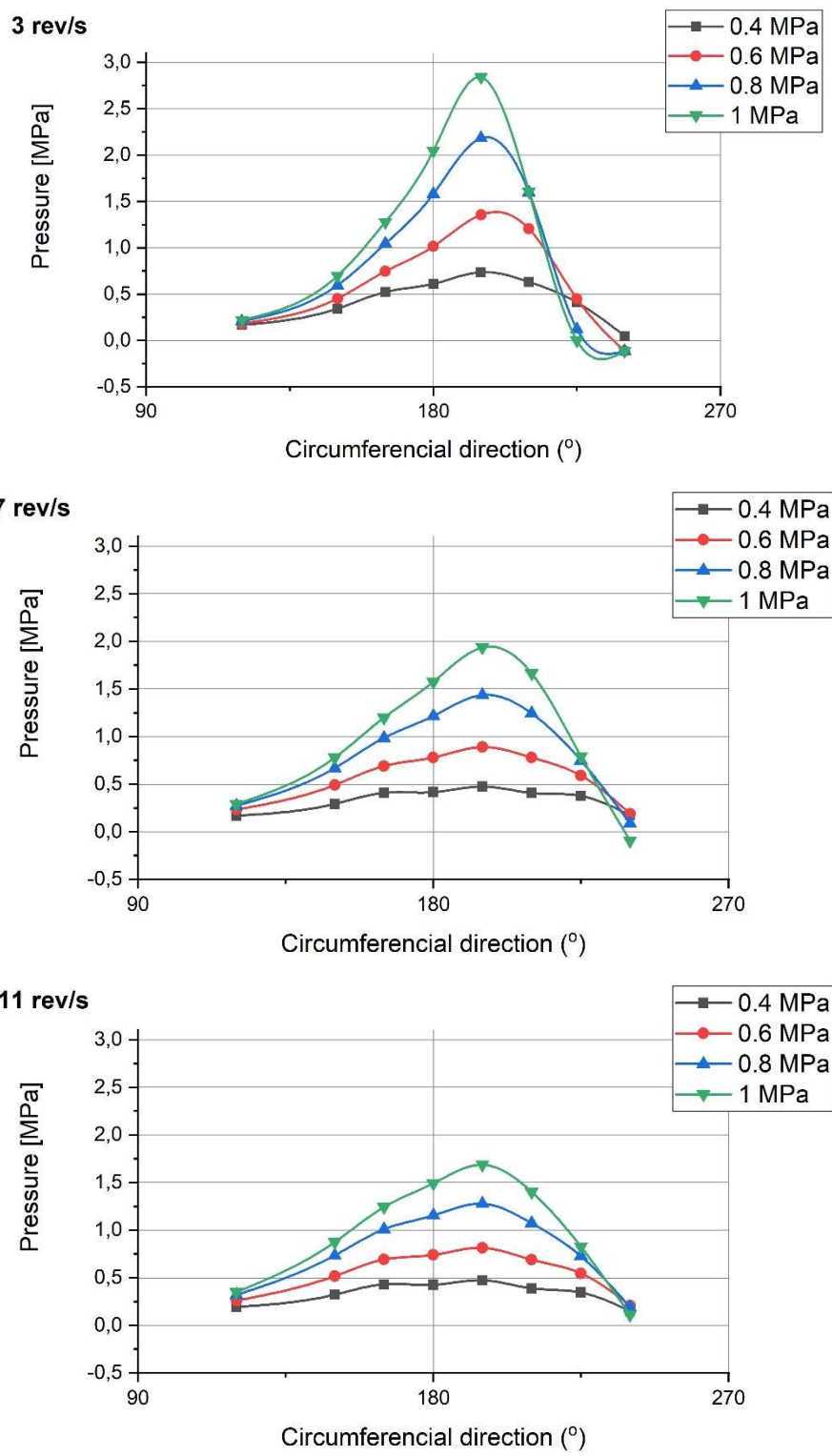

Fig. 6. Measured pressure distributions in the bearing for different shaft speeds;
 a) 3 rev/s, b) 7 rev/s, c) 11 rev/s

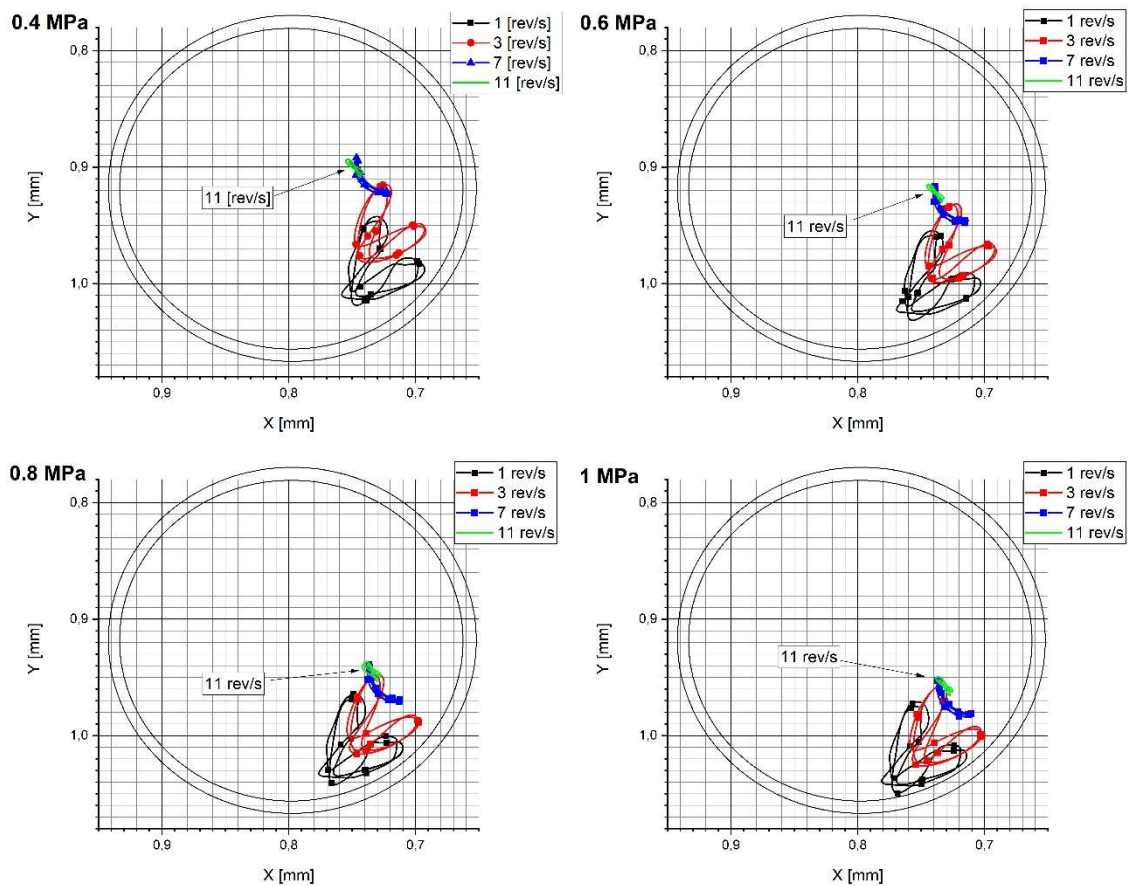

Fig. 7. Measured orbits of the shaft axis in the bushing for loads from 4 to 20 kN (specific pressure 0.4 to 1 MPa)

The graphs of the measured pressure distributions in the lower half of the bushing have a typical geometry. The increase in load for each of the rotational speeds causes the response of the lubricating film in the form of an increasing pressure field. When working at low speed, when the load increases, the pressure distribution graphs show a low pressure zone where cavitation can occur that could have a destructive effect on the bearing.

The trajectories of journal center located inside the experimentally determined clearance circles allow an approximate determination of the thickness of the lubricating film. Since the trajectories registered on both sides of the bushing were very similar, the graphs show the trajectories measured on one of the sides. The estimated thickness of the lubricating film is shown in the graph below (Fig. 8). Considering the smoothness of the surface of the sliding couple, the minimum thickness of the lubricating film can be approximated. It is usually assumed in approximate calculations that the minimum thickness (h_{min}) of the lubricating film is a sum of the roughness of the journal and the bushing (28).

$$h_{min} = k_m (R_p journal + bush) = 0.5(0.32 + 12) = 6.16 \mu m \quad (28)$$

$k_m = 0.5$ – material factor for white metal and babbits

$R_{pjournal} = 0.32 \mu\text{m}$ – surface grinding

$R_{pbush} = 12 \mu\text{m}$ – internal turning of polymer bush

In the analyzed case, the minimum film thickness was assumed as $8 \mu\text{m}$ (28). Considering the fact that in the typical case, in the stern tube bearing on the vessel there are specific pressures of 0.4 - 0.5 MPa, it can be stated that the bearing works in the hydrodynamic lubrication range even at a minimum speed of 1 rev/s. What is important, the bearing also has a clear margin of hydrodynamic load capacity. For specific pressures of 0.5 MPa, the lubrication film reaches a thickness of $70 \mu\text{m}$. This is a significant value, and it can be assumed that in the case of slight misalignment, the shaft will not come into contact with the bushing.

It is worth paying attention to the size and shape of the orbits. For lower speeds, the orbits have the shape of eights and are quite large. The work stabilizes and the vibrations become practically indiscernible for work with speeds above 7 rev / s.

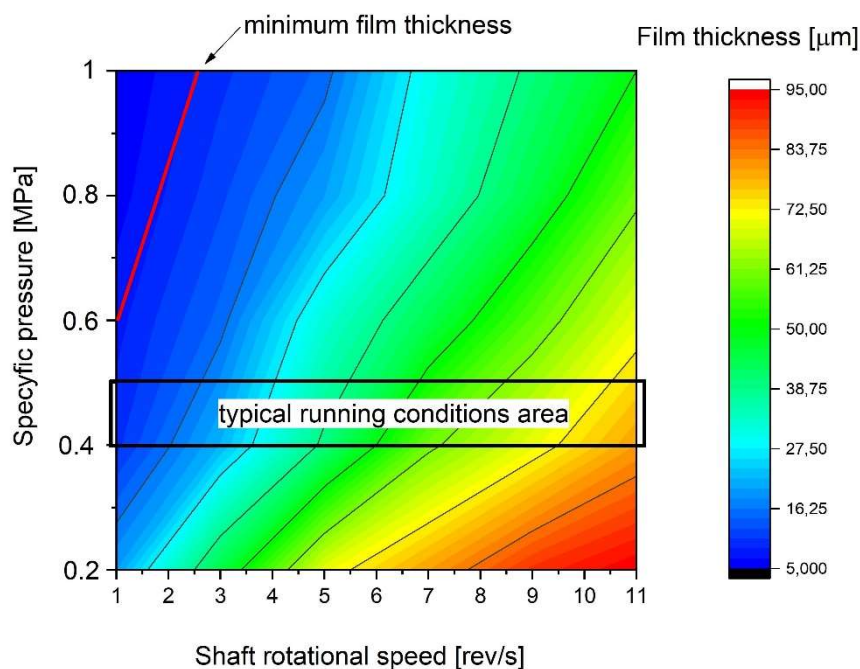

Fig. 8. The thickness of the lubricating film determined on the basis of experimental tests

4. Conclusions

The ship's stern tube bearing with the ratio of length to diameter $L / D = 2$ lubricated with oil under typical operating conditions works in the area of full fluid friction with a significant margin of hydrodynamic load capacity. This is a significant advantage over water lubricated bearings, which, if they work in the area of liquid friction, have thin lubricating films and it is difficult to assess the hydrodynamic load capacity.

The friction coefficient of an oil-lubricated bearing under typical conditions is around 0.015 - 0.02. It is a small value but still it is larger than in the case of oil lubricated bearings. According to the author, the energy losses resulting from the use of an oil lubricated bearing are small. It seems illusory to indicate lower motion resistance of bearing lubricated with water as its advantages. Working in the area of mixed friction, thin lubricating films while working in the area of liquid friction, cause that the wear process in a bearing lubricated with water takes place throughout the entire service life.

Bearing the ship's propeller shaft using oil lubricated bearings with white metal bushing is not a cheap solution. Seals, which are subject to continuous wear are often the weakest point of such a solution. It seems that oil lubrication, especially with environmentally friendly biodegradable oils is a very interesting offer for ship owners who expect high durability and reliability (19)(29)(30).

Research into environmentally friendly oils is ongoing and the results will be published soon.

References

1. Lee J ung. Application of strain gauge method for investigating influence of ship shaft movement by hydrodynamic propeller forces on shaft alignment. Meas J Int Meas Confed [Internet]. 2018;121(February):261–75. Available from: <https://doi.org/10.1016/j.measurement.2018.02.067>
2. Litwin W, Olszewski A, Wodtke M. Influence of shaft misalignment on water lubricated turbine sliding bearings with various bush modules of elasticity. Vol. 490, Key Engineering Materials. 2011.
3. Hirani H, Verma M. Tribological study of elastomeric bearings for marine propeller shaft system. Tribol Int. 2009;42(2):378–90.
4. Litwin W. Properties comparison of rubber and three layer PTFE-NBR-bronze water lubricated bearings with lubricating grooves along entire bush circumference based on experimental tests. Tribol Int [Internet]. 2015;90:404–11. Available from: <http://linkinghub.elsevier.com/retrieve/pii/S0301679X15001401>
5. Wojciech Litwin. WATER LUBRICATED MARINE STERN TUBE BEARINGS – ATTEMPT AT ESTIMATING HYDRODYNAMIC CAPACITY. In: ASME/STLE International Joint Tribology Conference IJTC2009 October 19-21, 2009, Memphis, Tennessee, USA. 2009. p. 1–3.
6. Dong C, Shi L, Li L, Bai X, Yuan C, Tian Y. Stick-slip behaviours of water lubrication polymer materials under low speed conditions. Tribol Int [Internet]. 2017;106(October 2016):55–61. Available from: <http://dx.doi.org/10.1016/j.triboint.2016.10.027>
7. Litwin W, Olszewski A. Assessment of possible application of waterlubricated sintered brass slide bearing for marine propeller shaft. Polish Marit Res. 2012;19(4).
8. Yamajo S, Kikkawa F. Development and Application of PTFE Compound Bearings. Dyn Position

- Conf. 2004;
9. Yuan C, Guo Z, Tao W, Dong C, Bai X. Effects of different grain sized sands on wear behaviours of NBR/casting copper alloys. *Wear* [Internet]. 2017;384–385:185–91. Available from: <http://dx.doi.org/10.1016/j.wear.2017.02.019>
 10. Dong CL, Yuan CQ, Bai XQ, Yang Y, Yan XP. Study on wear behaviours for NBR/stainless steel under sand water-lubricated conditions. *Wear*. 2015;332–333:1012–20.
 11. Wood RJK. Marine wear and tribocorrosion. *Wear* [Internet]. 2017;376–377:893–910. Available from: <http://dx.doi.org/10.1016/j.wear.2017.01.076>
 12. Zero oils means zero environmental impact. *Nav Archit*. 2012;
 13. Guo Z, Yuan C, Liu A, Jiang S. Study on tribological properties of novel biomimetic material for water-lubricated stern tube bearing. *Wear* [Internet]. 2017;376–377:911–9. Available from: <http://dx.doi.org/10.1016/j.wear.2017.01.081>
 14. Wang H, Liu Z, Zou L, Yang J. Influence of both friction and wear on the vibration of marine water lubricated rubber bearing. *Wear* [Internet]. 2017;376–377:920–30. Available from: <http://dx.doi.org/10.1016/j.wear.2017.02.006>
 15. Bustos VA, Furlong OJ. Stick-slip friction: A Monte Carlo study. *Tribol Int* [Internet]. 2016;102:355–60. Available from: <http://linkinghub.elsevier.com/retrieve/pii/S0301679X16301736>
 16. Lv F, Rao Z, Ta N, Jiao C. Mixed-lubrication analysis of thin polymer film overlaid metallic marine stern bearing considering wall slip and journal misalignment. *Tribol Int*. 2017;109(November 2016):390–7.
 17. Prehn R, Hauptert F, Friedrich K. Sliding wear performance of polymer composites under abrasive and water lubricated conditions for pump applications. *Wear*. 2005;259(1–6):693–6.
 18. Litwin W. Experimental research on water lubricated three layer sliding bearing with lubrication grooves in the upper part of the bush and its comparison with a rubber bearing. *Tribol Int*. 2015;
 19. Beran E. Experience with evaluating biodegradability of lubricating base oils. *Tribol Int* [Internet]. 2008;41(12):1212–8. Available from: <http://linkinghub.elsevier.com/retrieve/pii/S0301679X08000595>
 20. Vengudusamy B, Grafl A, Novotny-Farkas F, Schöfmann W. Comparison of frictional properties of gear oils in boundary and mixed lubricated rolling-sliding and pure sliding contacts. *Tribol Int*. 2013;62:100–9.
 21. Del Din M, Kassfeldt E. Wear characteristics with mixed lubrication conditions in a full scale journal bearing. *Wear*. 1999;232(2):192–8.
 22. Qin H, Zhou X, Zhao X, Xing J, Yan Z. A new rubber/UHMWPE alloy for water-lubricated stern



- bearings. *Wear* [Internet]. 2015;328–329:257–61. Available from:
<http://linkinghub.elsevier.com/retrieve/pii/S0043164815001258>
23. Zhimin Y, Zhou X, Qin H, Niu W, Wang H, Liu K, et al. Study on tribological and vibration performance of a new UHMWPE/graphite/NBR water lubricated bearing material. *Wear* [Internet]. 2015;332–333:872–8. Available from:
<http://dx.doi.org/10.1016/j.wear.2014.12.054>
 24. Bouyer J, Fillon M. Experimental measurement of the friction torque on hydrodynamic plain journal bearings during start-up. *Tribol Int* [Internet]. 2011;44(7–8):772–81. Available from:
<http://dx.doi.org/10.1016/j.triboint.2011.01.008>
 25. Gabiña G, Martin L, Basurko OC, Clemente M, Aldekoa S, Uriondo Z. Performance of marine diesel engine in propulsion mode with a waste oil-based alternative fuel. *Fuel* [Internet]. 2019;235(January 2017):259–68. Available from: <https://doi.org/10.1016/j.fuel.2018.07.113>
 26. Bodger L, Helma S, Sasaki N. Vibration control by propeller design. *Ocean Eng* [Internet]. 2016;120:175–81. Available from: <http://dx.doi.org/10.1016/j.oceaneng.2015.10.006>
 27. Owen D, Demirel YK, Oguz E, Tezdogan T, Incecik A. Investigating the effect of biofouling on propeller characteristics using CFD. *Ocean Eng* [Internet]. 2018;159(February):505–16. Available from: <https://doi.org/10.1016/j.oceaneng.2018.01.087>
 28. Neale MJ. *THE TRIBOLOGY HANDBOOK*. 2nd ed. Butterworth-Heinemann; 1995. 582 p.
 29. Zulkifli NWM, Azman SSN, Kalam MA, Masjuki HH, Yunus R, Gulzar M. Lubricity of bio-based lubricant derived from different chemically modified fatty acid methyl ester. *Tribol Int*. 2016;93:555–62.
 30. Arumugam S, Sriram G, Ellappan R. Bio-lubricant-biodiesel combination of rapeseed oil: An experimental investigation on engine oil tribology, performance, and emissions of variable compression engine. *Energy* [Internet]. 2014;72:618–27. Available from:
<http://dx.doi.org/10.1016/j.energy.2014.05.087>