

Experimental Research on Water Lubricated Three Layer Sliding Bearing with Lubrication Grooves in the Upper Part of the Bush and Its Comparison with a Rubber Bearing

Wojciech Litwin wlitwin@pg.gda.pl

Gdansk University of Technology

Faculty of Ocean Engineering and Ship Technology

ul. Narutowicza 11/12

80-233 Gdansk

Poland

Abstract

One of the more interesting, currently available water lubricated bearing materials is a three layer composite. Each of its layers has an important function. Specially prepared sliding surface ensures minimum resistance. Following running-in its smoothness becomes very high and the bearing may continue working under fluid lubrication regime. NBR layer ensures bearing elasticity, good vibration damping properties and insusceptibility to shaft axis misalignment. The external brass layer makes fitting the bearing easier.

Experiment results of the conducted research were compared with those for a rubber bearing of similar geometry.

Key words:

Water lubricated bearings, propeller shaft bearings, marine bearings, hydrodynamic lubrication

1. INTRODUCTION

Increased level of environmental awareness and creation of new legislative measures have in recent years stirred a growing interest in environmentally friendly technologies. This trend also applies to propulsion shaft bearings in shipbuilding, hydropower, water pumps and other industrial sectors. The increased interest is especially noticeable in the field of water lubricated bearings and biodegradable lubricating agents.

One example of legislative changes in the area may be a draft regulation entitled "Small Vessel General Permit (sVGP)" prepared by the United States Environmental Protection Agency which states that "environmentally acceptable" lubricants have to be employed on every ship built after 2013. This means that these lubricating agents have to be biodegradable and non-toxic. Environmentally friendly

lubricants should also be used on older ships, and if this is not possibility the necessity of employing a regular, standard solution must be clearly documented by the shipowner.

Currently, water lubricated bearings find wide use in numerous areas of technology. Pros and cons of various types of sliding materials have been debated for years (Smith (1), Hother-Lushington (2)). Bearings presently used in shipbuilding and other industries include rubber bearings (Orndorff (3)–(5), Wang N.(6), Wang Y.(7)), polymer bearings (Gao (8), Ginzburg (9); Laskey (10); Sverko and Sesta (11)), as well as composite bearings (Ford (12)). In addition, there are bearings made of various newly developed multi-layer materials providing custom-made properties (Yamajo (13)). Much scientific research is also conducted on other types of water lubricated bearings. These are mostly ceramic (Nisaka (14), Jahanmir (15), sintered metal alloy (Jun-hong Jia (16), Litwin (17)), and foil bearings (Olszewski (18), Hryniewicz (19)).

Shipbuilding industry is dominated by well-known constructions made of rubber, polymer and composite materials. Rubber and polymer bearings are used in pumps, as are ceramic and various sintered ones. In water turbines one can encounter both polymer and rubber bearings, while ceramic bearings are currently in the implementation-testing phase.

All water lubricated journal bearings may be divided into two basic groups - rigid bearings, in which the bush does not experience any significant deformation resulting from hydrodynamic pressure, and elastic bush bearings. Classified as rigid are all the bearings in which the modulus of volume elasticity is greater than the approximate value of 3000 MPa. This includes all kinds of bronze bearings, ceramic bearings, as well as majority of composite bearings constructed on the basis of epoxide and phenol resins. Other bearing types - rubber, polymer, foil etc. - belong to the group of elastic bearings. Among their fundamental advantages is greater tolerance of work under conditions of shaft misalignment

2. ORIGIN AND PURPOSE

Experiment-based research on various types of sliding water-lubricated bearings -including rigid, composite and elastic plastic ones (Litwin (20,21,22)), has been conducted at the Gdańsk University of Technology in recent years. The research has unequivocally demonstrated that a properly designed hydrodynamic water lubricated journal bearing is capable of working under a fluid lubrication regime at loads and speeds typical of practical applications. Unfortunately, low viscosity of the lubricating agent i.e. water, as well as the absence of effect of increased viscosity as a function of pressure, result in a very low minimum water film thickness, usually not exceeding a few dozen micrometers, despite obtaining full hydrodynamic lubrication.

Research carried out by the author, as well as results available in literature, demonstrate that elastic polymer bush bearings have lower hydrodynamic load capacity than comparable rigid bearings

(i.e. made of composite materials), and under identical load values they work at smaller film thicknesses. This is due to local deformation of bush surface resulting from pressure generated in the lubricating film. As a consequence, the lubrication gap changes its shape within the area of increased pressure. This surface deformation may reach value of theoretical minimum lubrication gap thickness and result in significant limitation of the forming hydrodynamic pressure, which substantially impacts the bearing's load capacity.

Unfortunately, all of the bearing types employed in practical applications present certain shortcomings. Rigid composite bearings usually have inferior surface quality to comparable polymer bearings and as such may in certain situations have lower hydrodynamic load capacity. They are also more susceptible to shaft misalignment. As a result, they are susceptible to frequent occurrences of local stress concentrations and overheating of composite material resulting in bush delamination. In addition, rigid bush materials offers only limited dampening of vibrations. It is for this very reason that materials of lower modulus of elasticity are so intensively searched for.

Rubber bearings have been employed in shipbuilding as propeller shaft bearings for several decades. In the past, when natural rubber containing sulphur was used, the corrosive environment frequently led to shaft journal destruction. Nitrile rubber (NBR) which has now been employed for years, does not create this problem, however, it does create significant resistance of movement at start-up, which in certain situations results in substantial wear of journal's sliding surface.

The goal of the work was to investigate behavior of a modern, three layer bearing of an innovative design. Its construction pointed to the possibility of obtaining optimum properties, i.e. low resistance of movement - including at start-up, significant bush elasticity, high surface smoothness and good dampening properties (Fig.1).

3. CHARACTERISTIC OF INVESTIGATED BEARINGS AND RESEARCH METHODOLOGY

The research object was a three layer bearing. The obtained results were compared with those of a rubber bush bearing of practically identical geometry (Fig. 1.). In both bearings, the lubrication grooves were present only in the upper part of the bush which was not under load. This facilitated occurrence of hydrodynamic phenomena.

Geometry of the grooves differed somewhat due to technological reasons at the manufacturing stage. However, it is believed that this fact did not have any significant impact on hydrodynamic phenomena occurring between journal and bush.

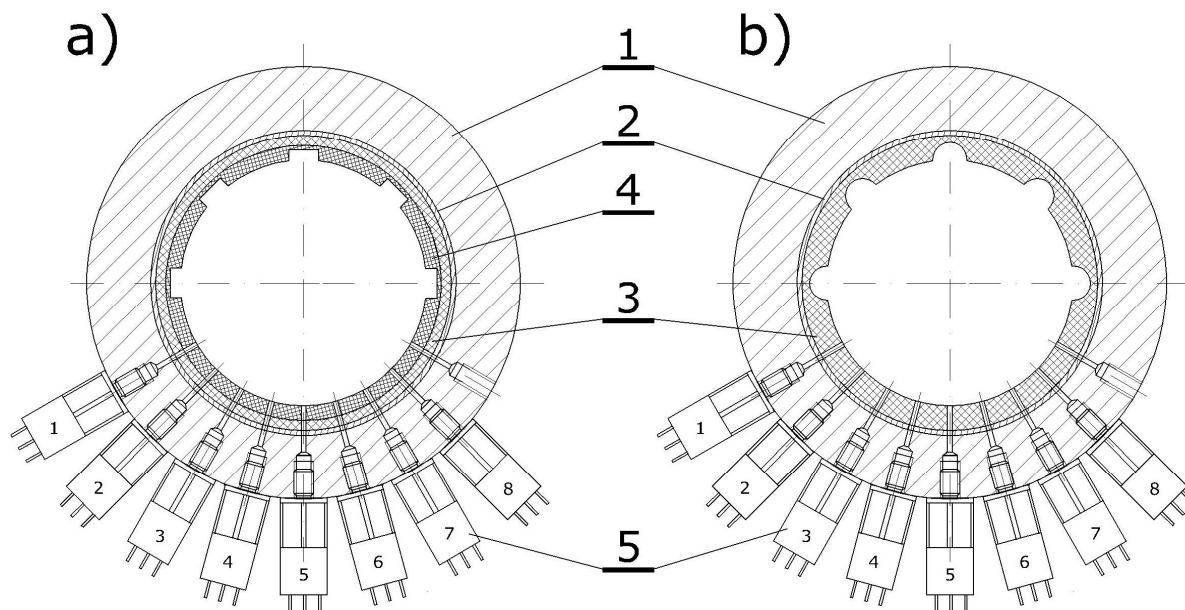

Fig.1. Tested bearings; a) three layer bearing, b) rubber bearing; 1 - steel sleeve, 2 - bearing steel sleeve, 3 - NBR, 4 – PTFE layer, 5 – pressure sensors installed in steel sleeve

Detailed description of the test rig may be found in earlier works (Litwin (20 - 21)).

The investigated bearing was 100 mm in shaft diameter and 200 mm in bush length (Fig. 2.), as such it represented typical proportions of a propeller shaft stern tube bearing. The shaft was made of marine grade stainless steel X10CrNi18-8.

The bearing was placed inside a massive steel housing which was fit with two sets of eight pressure sensors located on two planes, allowing for measuring pressure distribution between the journal and the bush (Fig. 2). The bearing assembly was closed on both sides by covers equipped with seal rings. This allowed for forcing movement of the lubricating agent i.e. water, through the bearing. Two pairs of movement sensors were installed in the covers, allowing for recording of the shaft axis trajectory. The test rig was unique in offering the possibility of recording the boundary journal position in the bush as a function of load defined by the clearance cycle. Radial load was placed on the bush through rollers with antifriction bearings in a way which allowed for measuring the moment of friction and calculating the friction coefficient. However, this method presented certain limitations. The rollers' resistance of movement caused a certain degree of error in measuring low resistance levels (Fig. 2). The drive was supplied by an electric motor along with reduction gears which provided the test rig with the maximum torque of approximately 160 Nm. This allowed for start-up and operation of the test rig under the load of 16 kN. This fact made start-up and running in the boundary friction regime under full load impossible during testing of certain polymers when stick-slip phenomena occurred.

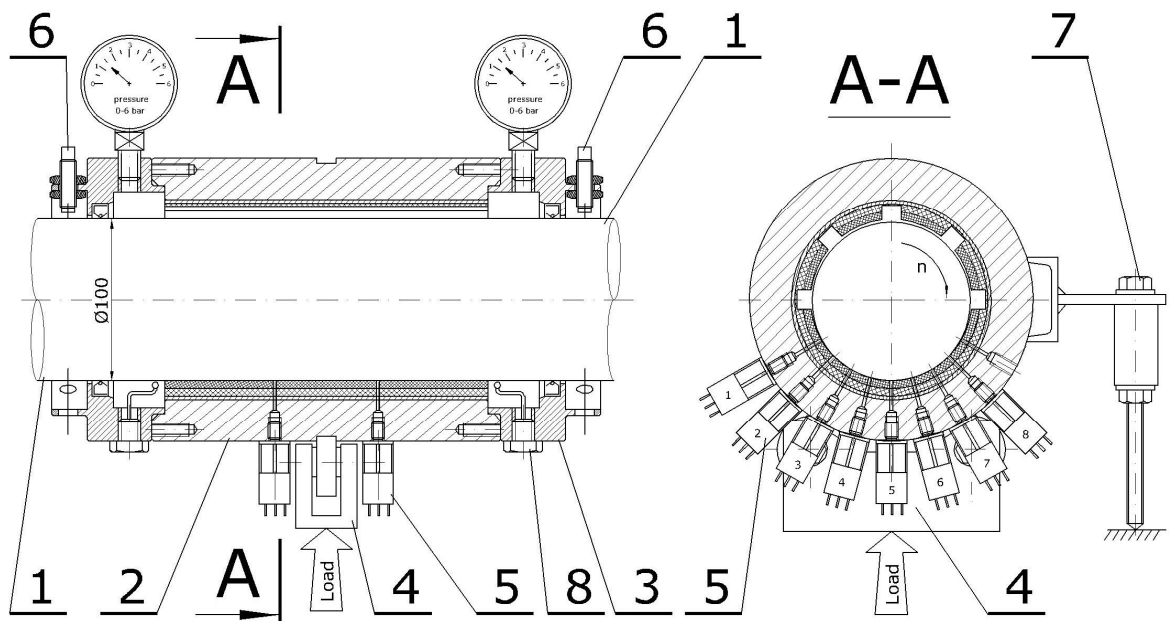

Fig.2. Test rig - tested bearing unit; 1-main shaft, 2- tested bearing housing with tested bearing located inside, 3- cover (right side) with seal, 4- support with roller bearings – load application location, 5- pressure sensors (in two surfaces, left and right), 6 – two pairs of proximity sensors, 7- arm with force sensor for twisting torque measurement

The tests were carried in conditions typical for the size of the investigated bearings, which may find use on a small vessel or in hydro-power industry as water turbine shaft bearing. The revolving speed was modified in the range of 0 do 11 rev/s. Maximum pressure during the tests was at the level of 0.8 MPa (force 16kN). The bearing was lubricated with fresh water at the temperature of 10 degree Celsius.

Test parameters are presented in Table 1 below.

Table 1. Bearing data

No.	Bearing type	Shaft diameter/ bearing length/ diameter clearance/ [mm]	Loads [MPa]	Shaft speed [rev/s]
1	Three layers (PTFE/NBR/bras)	100/ 200/0.5÷0.6 /	0.2, 0.4, 0.6, 0.8	1, 2, 3, 5, 7, 9, 11
2	Rubber (NBR/brass)	100/ 200/0.4÷0.5 /	0.2, 0.4, 0.6	

The bearings had undergone the procedure of running-in prior to its tests. The measurements were initiated after the bearing had reached over twenty hours of work under various conditions.

4. MEASUREMENT RESULTS

Results of the conducted measurements are presented below

Values of the moment of friction and the coefficient of friction were calculated based on recorded values of the friction force (Fig. 2, Subassembly No. 7). The increase in resistance during start-up in the

load function is nearly linear (Fig. 3 a and b). However, it turns out that the coefficient of friction decreases with applied load (Fig. 3 c and d). In case of the NBR bearing, the resistance of movement and therefore also the magnitude of the coefficient of friction depend strongly on time span between successive start-ups (Fig. 4). Due to limited torque of approximately 160Nm, it was impossible in case of the NBR bearing to carry out measurements of the resistance of motion during start-ups at the load of 0.2MPa after a pause longer than two hours (Fig. 4).

Friction coefficient value was calculated based on recorded moment of friction values (Fig. 3). Pressure distribution in the space between the journal and the bush was recorded on two planes. The recorded values are practically identical, therefore the graphs below (Fig. 5 ÷ 7) present average measurement values. The magnitude of instantaneous pressure changes depends on the orbit created by the journal in its bush. This orbit becomes progressively smaller (Fig. 8) with increasing shaft speed, which causes decreasing pulsations of pressure recorded by the sensors installed along the bush perimeter.

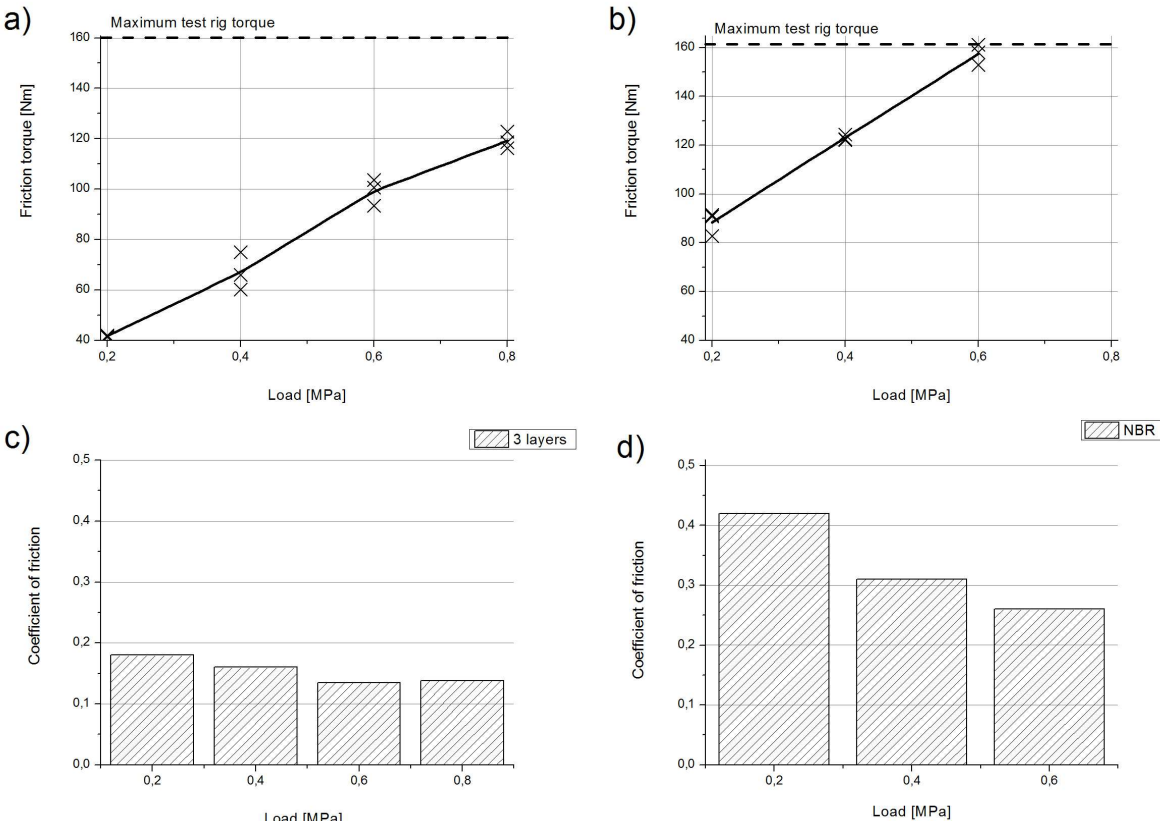

Fig.3. Measured friction torque and calculated coefficient of friction values during shaft start-up as function of load, few minute pauses between starts; a, c) three layer bearing, b, d) NBR bearing

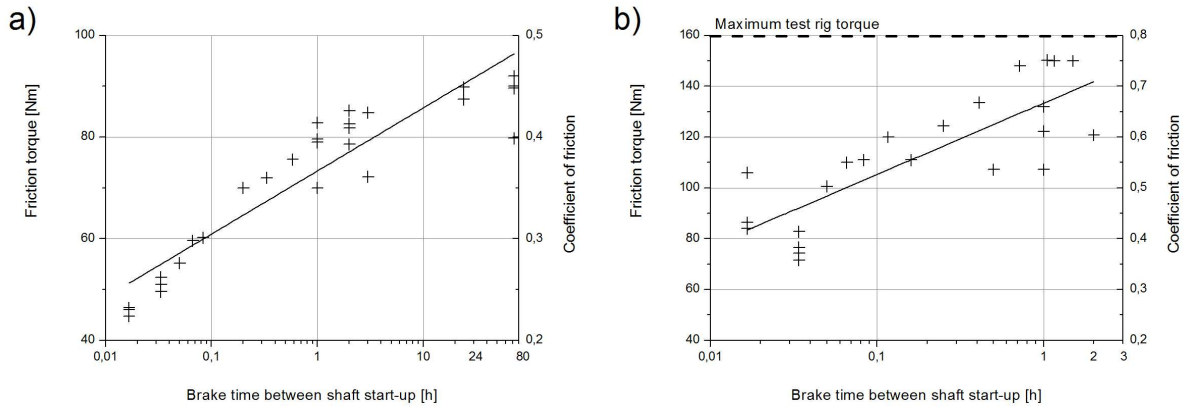

Fig.4. Measured coefficient of friction during shaft start-up;
 a) NBR bearing, load 0.1MPa b) NBR bearing, load 0.2MPa

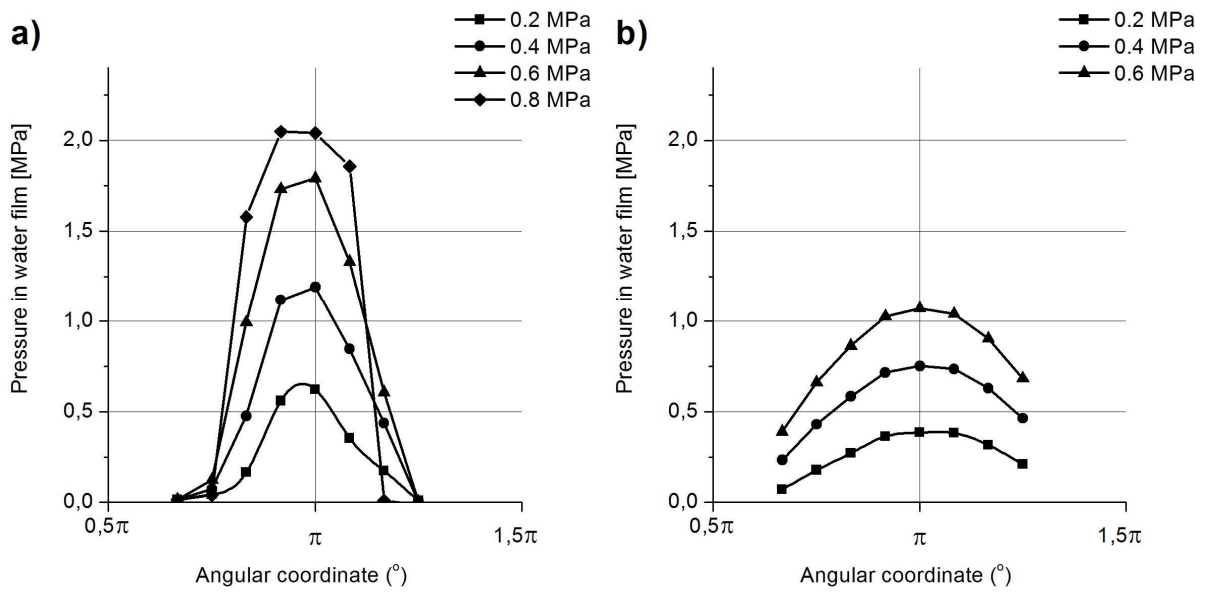

Fig. 5 Average pressure distribution in water film measured in both planes of the lower bush half, speed 3 rev/s: (a) sintered bush bearing and (b) rubber bearing

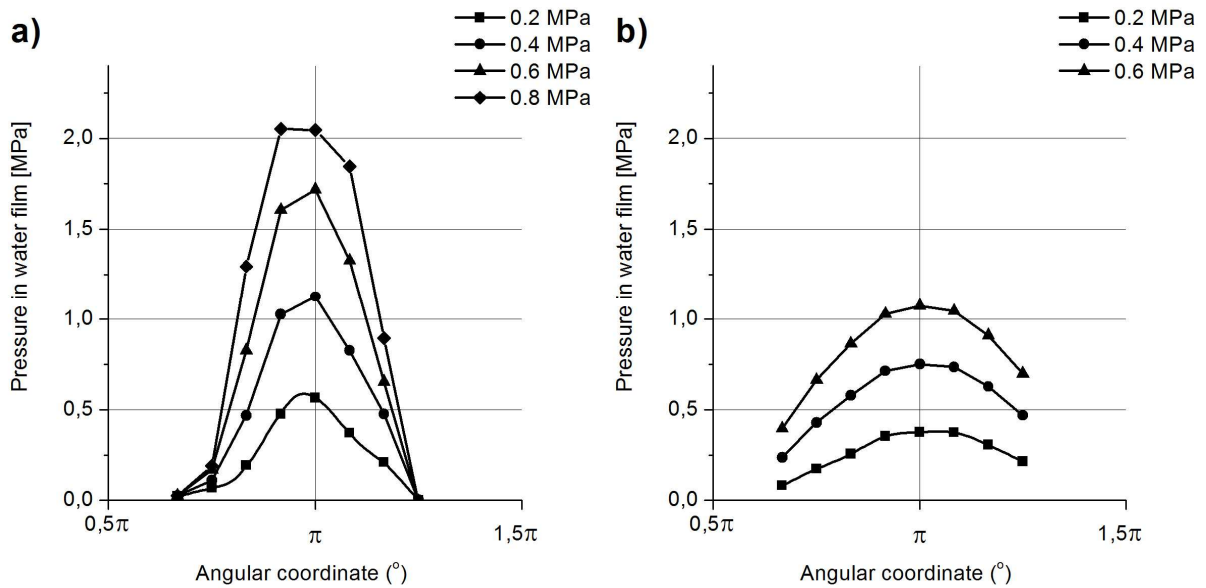

Fig. 6 Average pressure distribution in water film measured in both planes of the lower bush half, speed 7 rev/s: (a) sintered bush bearing and (b) rubber bearing

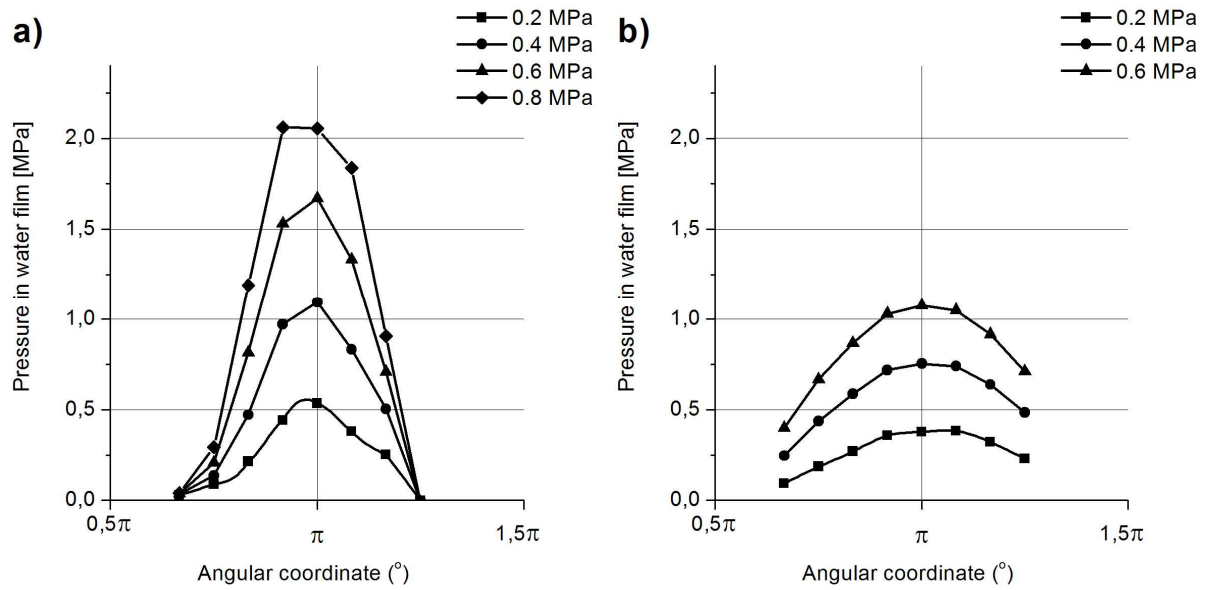

Fig. 7 Average pressure distribution in water film measured in both planes of the lower bush half, speed 11 rev/s: (a) sintered bush bearing and (b) rubber bearing

Measurements of shaft's trajectory and boundary positions demonstrated high elasticity of the bush material, as well as certain faults in the shape of bush's sliding surfaces (Fig. 8). This problem applies to nearly all rubber, polymer and composite bearings. In the past, ideally cylindrical bush shape was possible to obtain only in those bronze and sintered bronze bearings which had ground and polished surfaces. Since for loads in excess of 0.2 MPa there occurred significant bearing deformations, it was not possible to assess the thickness of the lubricating film.

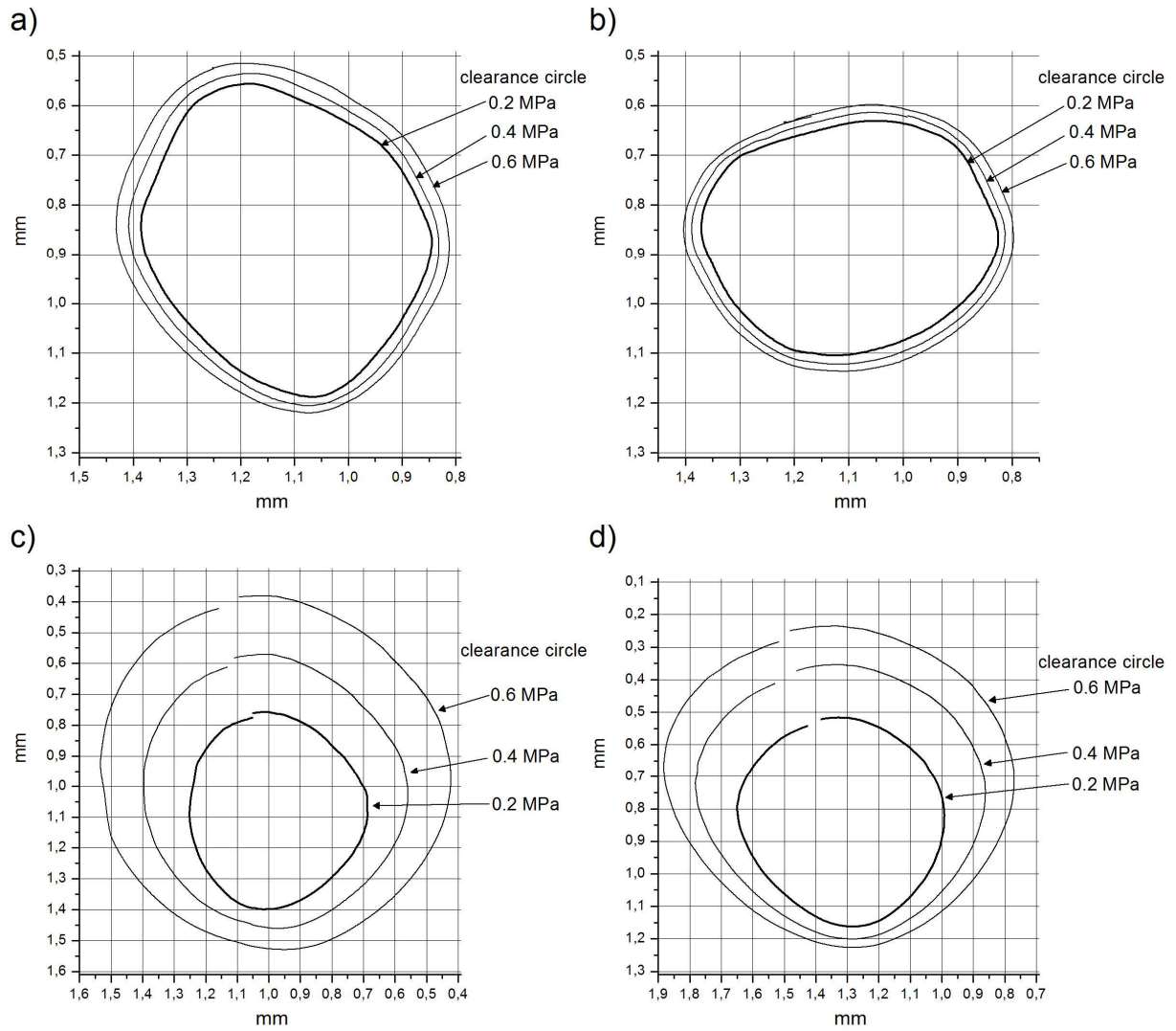

Fig. 8 Boundary location of the shaft center in the bush as a function of load ranged from 0.2 ÷ 0.6 MPa; (a) three layer bearing left side, (b) three layer bearing right side, (c) rubber bearing left side, (d) rubber bearing right side

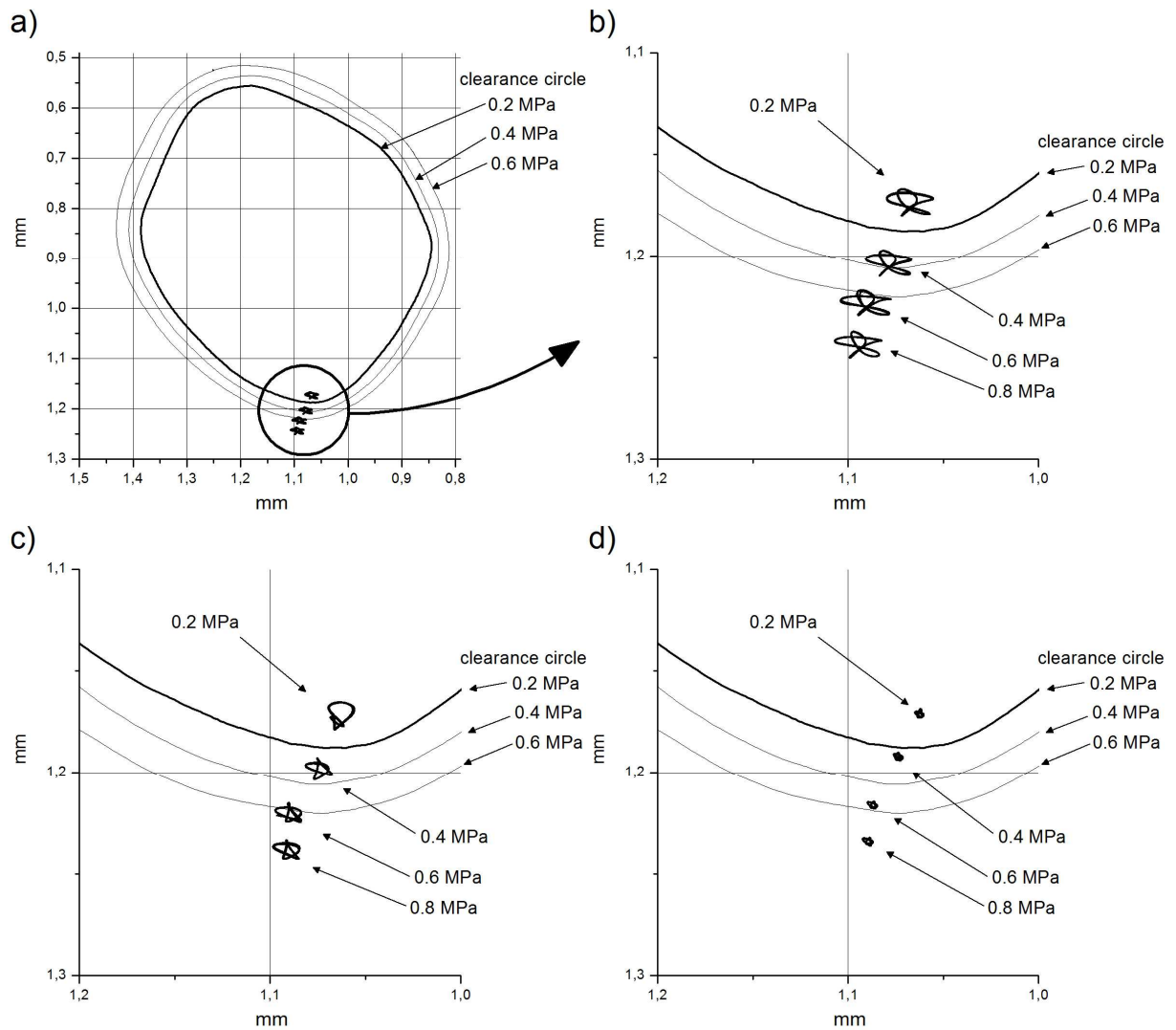

Fig. 9 Three layers bearing shaft orbits in measured clearance circles, load $0.2 \div 0.8$ MPa, shaft speed 3 rev/s; (a) general view 3 rev/s, (b) magnified view of orbits 3 rev/s, (c) magnified view of orbits 7 rev/s, (d) magnified view of orbits 11 rev/s,

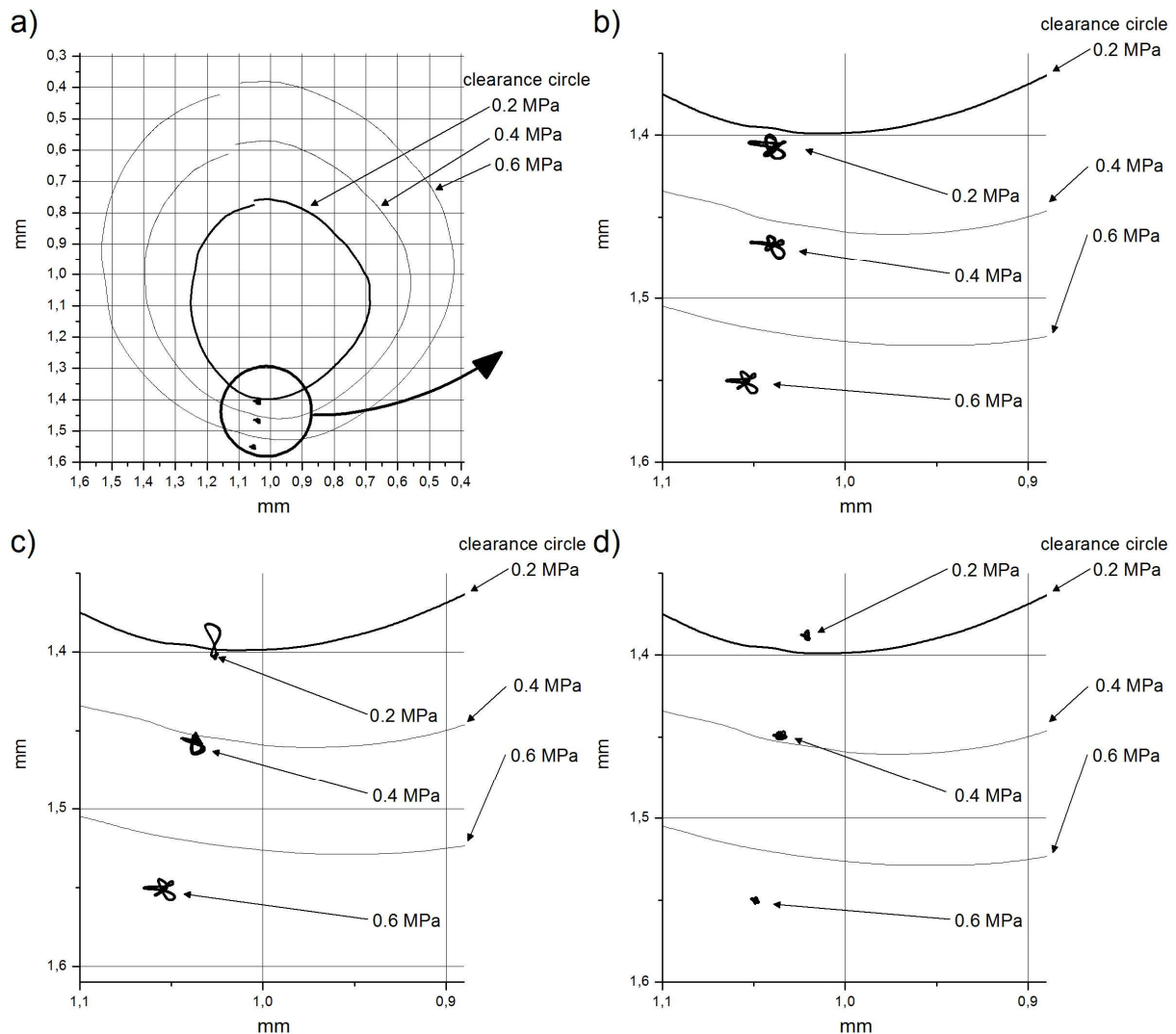

Fig. 10 Rubber bearing shaft orbits in measured clearance circles, load $0.2 \div 0.8$ MPa, shaft speed 3 rev/s; (a) general view 3 rev/s, (b) magnified view of orbits 3 rev/s, (c) magnified view of orbits 7 rev/s, (d) magnified view of orbits 11 rev/s,

5. DISCUSSION

The resistance of motion and friction coefficient graphs (Fig. 3, 4) show significant differences between the two investigated bearings. The three layer bearing with its PTFE sliding surface has significantly lower static friction coefficient values than the NBR bearing. Furthermore, the value of the friction coefficient of the rubber bearing considerably increases in the function of time during which the shaft remained at rest between successive start-ups. Even at loads as small 0.2 MPa it was not possible to activate the test rig following a 3 hour long pause in operation (Fig. 4b), despite the fact that the drive motor along with transmission provided approximately 160Nm of torque. Therefore, in order to investigate the characteristic of this phenomenon, a series of similar start-ups was run for a smaller load of 0.1 MPa (Fig. 4a). The calculated trendline points to an increase in the coefficient of friction, which reaches its maximum values after the test rig was at rest for longer than 24 hours. This value is

as much as 100% greater than the value of measurements carried out after a brief pause of only a few minutes.

During operation at speeds over 1 rev/s, the resistance of motion in both bearings was similar and due to difficulties in recording small forces of friction stemming from construction characteristic of the test rig, it is hard to unequivocally assess which bearing had lower resistance of motion.

Very interesting results were obtained in a long-duration test run under conditions of limited cooling, with the water pump turned off. The PTFE sliding surface bearing run with no difficulties for over three hours and the measurements were stopped when the temperature set itself at a safe level. During tests of the NBR bearing, it unexpectedly locked after an hour of operation due to local overheating of the bush. It was concluded that the bearing locked as a result of increase in the volume of the bush material and its gripping of the shaft. There was no permanent damage to the bush and the journey, as the torque overloaded inverter turned itself off. Similar situations occur on ships when a cooling system failure or filter clogging take place. The difference lies in the fact that the very high torque of ship's engine causes such level of overheating in the bush that it destroys the bearing. There are known cases of polymer bushes melting down and flowing out of their housings. Such incidents are extremely dangerous as they can lead to marine disasters and usually find their conclusion in courts.

Based on the conducted measurements it is difficult to unequivocally conclude whether any of the bearings worked in full hydrodynamic lubrication regime. It has to be noted, that the author's intention was to compare bearings of practically identical geometries. Unfortunately, due to technological reasons, the bush geometry was not perfect and there were certain faults in its shape. First and foremost, it was not perfectly cylindrical (Fig. 8). In addition it proved impossible to manufacture bearings of virtually the same clearance diameter.

Measurements of the clearance circles show considerably greater elasticity of the NBR bearings in comparison to the three layer bearing. It is also characteristic of the NBR bearing that the magnitude of deformation resulting from applying increasingly large loads changes circumferentially. (Fig. 8 c and d). This stems from the presence of sizable lubrication grooves which were machined along the bush perimeter in its upper half (Fig. 1).

In analyzing the distribution of hydrodynamic pressure in both bearings one can notice significant differences in the value of the maximum hydrodynamic pressure (Fig. 6 and 7). This is a typical phenomenon which had already been confirmed in earlier studies (Litwin 20 – 22). Maximum pressure value in a lubrication film depends strongly on the elasticity of bush material. It stems from the deformation of bush surface under the impact of hydrodynamic pressure, which has an effect on geometry of the lubrication gap. Approximate calculations of the lifting force based on the measurements of pressure in the lubrication film were conducted. Based on previous experiences it was assumed that lubrication film would appear and pressure would have constant, significant values

along approximately 80% of bearing length (Fig. 11). Measured pressure values and calculated lifting force values in both of the investigated bearings are presented in table below (Table 2). Hydrodynamic forces are sufficient to fully carry the applied load.

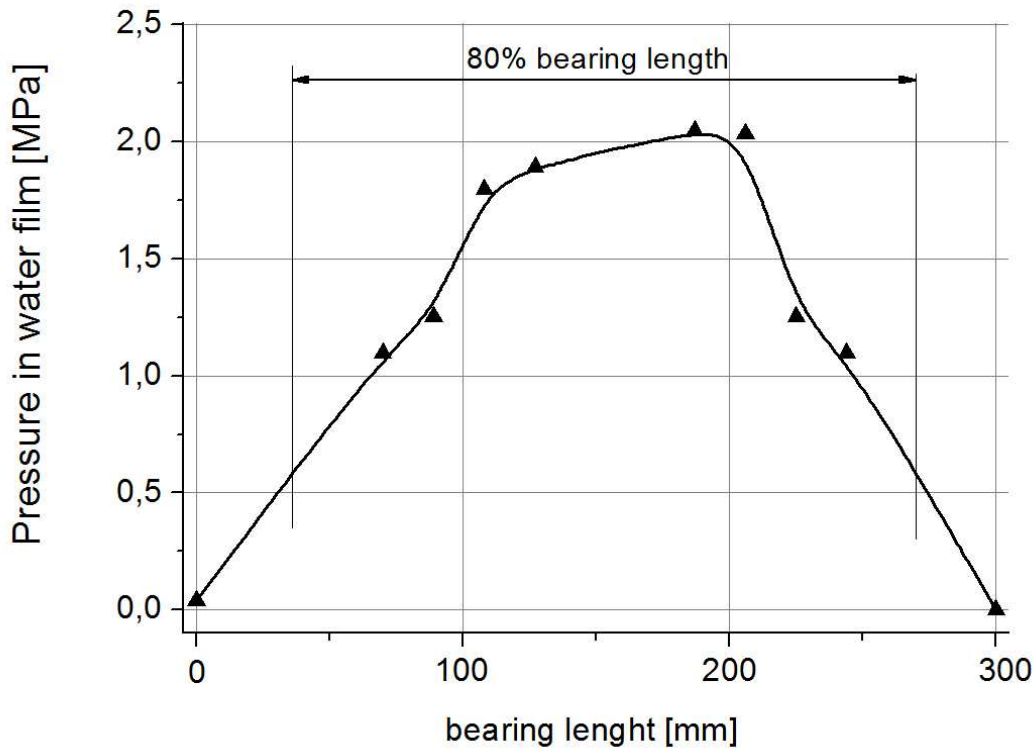

Fig. 11 Average pressure distribution in water film measured along bush, eight pressure sensors located in 300mm length bush, load 0.5MPa, shaft speed 11 rev/s

Differences between the applied load and the resulting lifting force are small and amount to a few percent. Therefore, one may conclude that full hydrodynamic lubrication took place in both bearings.

Table 2. Applied load and calculated approximated lifting loads of tested bearings

three layers bearing						NBR bearing					
applied load 0.6MPa (12kN)		applied load 0.4MPa (8kN)		applied load 0.2MPa (4kN)		applied load 0.6MPa (12kN)		applied load 0.4MPa (8kN)		applied load 0.2MPa (4kN)	
pressure measured by sensors	calculated lifting force	pressure measured by sensors	calculated lifting force	pressure measured by sensors	calculated lifting force	pressure measured by sensors	calculated lifting force	pressure measured by sensors	calculated lifting force	pressure measured by sensors	calculated lifting force
[MPa]	[N]	[MPa]	[N]	[MPa]	[N]	[MPa]	[N]	[MPa]	[N]	[MPa]	[N]
0,0371	89,07	0,0343	82,30	0,0297	[N]	0,3990	958,53	0,2460	590,92	0,0930	[N]
0,2072	304,91	0,1364	200,71	0,0886	212,81	0,6676	982,23	0,4370	642,97	0,1859	446,52
0,8148	1467,95	0,4723	850,88	0,2147	315,87	0,8670	1562,07	0,5871	1057,76	0,2695	396,55

1,5299	3073,81	0,9732	1955,43	0,4416	795,54	1,0307	2070,86	0,7188	1444,29	0,3575	644,11
1,6701	3473,70	1,0954	2278,39	0,5344	1073,80	1,0772	2240,47	0,7537	1567,76	0,3779	759,18
1,3325	2677,34	0,8338	1675,27	0,3805	791,46	1,0498	2109,19	0,7404	1487,51	0,3820	794,60
0,7089	1277,23	0,5050	909,74	0,2515	505,39	0,9166	1651,28	0,6388	1150,87	0,3222	647,42
-0,0112	-16,51	-0,0019	-2,80	-0,0032	-5,69	0,7108	1045,88	0,4853	714,08	0,2302	414,73
total lifting force [N]	12347,51		7949,93		3689,18		12620,51		8656,16		4103,11
LOAD [MPa]:	0,62		0,40		0,18		0,63		0,43		0,21

However, if both bearings had worked in the fluid film lubrication regime, the previously described locking of the journey and resulting emergency stop of the test rig would not have taken place. Consequently, it seems that in case of the highly elastic NBR bush material, there was incidence of local mixed lubrication in part of the bush close to the edges where the values of hydrodynamic pressure were minimal and there was practically no deformation. As a result, more heat was generated in the bush, which is what eventually brought the rig to a stop.

In analyzing trajectory graphs of the shaft axis (Fig. 9 and 10), one may observe that shaft orbits for the NBR bush bearing are usually below the experiment-measured clearance circle, which is a sign of considerable bush deformation and may confirm the hypothesis of local contact between the journey and bush edges. It is also characteristic that along with increase in shaft's revolving speed, the orbits become increasingly smaller (Fig. 9 and 10) and magnitude of hydrodynamic pressure changes in the lubrication film also falls progressively.

6. CONCLUSIONS

Attention should be paid to very minor resistance of movement, as well as low static friction values of the three layer bearing with PTFE sliding surface, which is not without significance for life span of a complete ship or water turbine propulsion system.

The bearing's work characteristic in complete fluid film lubrication regime under a wide range of conditions, as well as its low friction coefficient values are clear indications of its high quality and potential long lasting durability. It also worth noticing, that thanks to the low resistance of movement only a small amount of heat is generated in the bearing. This fact is of high importance in emergency situations, when the system propelling water through the bearing becomes damaged. The 3 hour long test performed without water flowing through the bearing, demonstrated acceptable level of increase in its temperature.

It is difficult to forecast how in a similar situation would behave an NBR bearing of typical geometry with lubrication grooves along its entire perimeter. Previous research indicates that such

bearing works in a mixed lubrication regime. However, it seems that in the situation when lubrication grooves are located along entire bearing perimeter the cooling conditions are better. For this reason, research on such bearings will be conducted in near future for an entire group of materials allowed by classification societies for use in shipbuilding.

Based on the conducted research, it may be concluded that in the analyzed case the three layer bearing would prove to perform better. It is also important to emphasize that despite its greater rigidity, the bearing still belongs to the group of elastic bush ones, and as such tolerates well occurrences of shaft misalignment which commonly take place in shipbuilding.

7. REFERENCES

1. Smith, W. V. (1973), "Material Selection Criteria for Water Lubrication," *Wear*, 25, pp 139–153.
2. Hother-Lushington, S. (1976), "Water Lubricated Bearings," *Tribology International*, 9, pp 257–260.
3. Orndorff, R. L. (1985), "Water-Lubricated Rubber Bearings, History and New Developments," *Naval Engineers Journal*, pp 39–52.
4. Orndorff, R. L. (2005), "From Lab to Field: New High Performance Water Lubricated Bearings;" *Proceedings of World Tribology Conference III*, Washington.
5. Orndorff, R. L. (2000), "New UHMWPE/Rubber Bearing Alloy," *ASME Journal of Tribology*, 122, pp 367–373.
6. Wang N., Meng Q., Pengpeng W., Geng T., Youan X. (2014), "Experimental Research on Film Pressure Distribution of Water-Lubricated Rubber Bearing With Multiaxial Grooves" *Journal of Fluids Engineering*, August 2013, vol. 135, pp 084501-1 – 084501-6
7. Wang Y. Shi X., Zhang L. (2014), "Experimental and numerical study on water-lubricated rubber bearings", *Industrial lubrication and Tribology*", no. 2, vol. 66, pp.282-288
8. Gao G., Yin D., Zhang X. (2014), "Numerical analysis of plain journal bearing under hydrodynamic lubrication by water" *Tribology International* 75, pp 31-38
9. Ginzburg, B. M., Tochil'nikov, D. G., Bakhareva, V. E., Anisimov, A. V., and Kireenko, O. F. (2006), "Polymeric Materials for Water-Lubricated Plain Bearings"; *Russian Journal of Applied Chemistry*, 79(5), pp 695–706.
10. Laskey Keith: "The non-metallic bearing – what you need to know"; *WORLD PUMPS* August 2006, pp 36 – 38.
11. ŠVERKO D., ŠESTAN A. (2010): "Experimental Determination of Stern Tube Journal Bearing Behaviour"; *BRODOGRADNJA* 61, pp 130 – 141.
12. Ford A. (2012): "New Composite seal and bearing technology for better performance"; *Marine / in detail - Wartsila Technical Journal* 01.2012.
13. Yamjo S., Kikkawa F. (2004): "Development and Application of PTFE Compound Bearings";
14. Nisaka, H. and Harano Maizawa, K. (2004), "Development on Ceramics Application to Water Turbine Bearings," *Turbomachinery*, 32, pp 681–686.
15. Jahanmir S., Ozmen Y., Ives L.K. (2004): "Water lubrication of silicon nitride in sliding"; *Tribology Letters*, Vol. 17, No. 3, pp 409 - 417.
16. Jun-hong Jia , Jian-min Chen, Hui-di Zhou, Jing-bo Wang, Hua Zhou (2004): "Friction and wear properties of bronze–graphite composite under water lubrication"; *Tribology International* 37 pp 423 – 429.
17. Litwin W., Olszewski A. (2014): *Water-Lubricated Sintered Bronze Journal Bearings—Theoretical and Experimental Research*;

18. Olszewski, A., Wodtke, M., and Hryniewicz, M. (2012), "Experimental Investigation of Prototype Water-Lubricated Compliant Foil Bearings," *Key Engineering Materials: Fundamentals of Machine Design*, 490, pp 97–105.
19. Hryniewicz, P., Wodtke, M., Olszewski, A., and Rzadkowski, R. (2009), "Structural Properties of Foil Bearings: A Closed-Form Solution Validated with Finite Element Analysis," *Tribology Transactions*, 52, pp 435–446.
20. Litwin, W. (2009), "Water-Lubricated Bearings of Ship Propeller Shafts Problems, Experimental Tests and Theoretical Investigations," *Polish Maritime Research*, 16, pp 42–50.
21. Litwin, W. (2010), "Influence of Main Design Parameters of Ship Propeller Shaft Water-Lubricated Bearings on Their Properties," *Polish Maritime Research*, 17, pp 39–45.
22. Litwin, W. (2011), "Influence of Surface Roughness Topography on Properties of Water-Lubricated Polymer Bearings: Experimental Research," *Tribology Transactions*, 5, pp 351–361.