

## EXPERIMENTAL STUDIES ON SPECIFIC CUTTING RESISTANCE WHILE CUTTING WITH NARROW-KERF SAWS

Kazimierz A. ORŁOWSKI

### Summary

The emergence of narrow-kerf technologies has encouraged scientists to conduct experimental studies of the effect of the kerf reduction upon specific cutting resistance (cutting pressure). An overall set (kerf), feed per tooth and saw blade thickness were input values in the carried out experiment. Therefore, besides changes of the total area of the cut, the effect of friction conditions between a saw blade, kerf walls and minor flanks was examined. The results obtained revealed that values of the specific cutting resistance for re-sawing process conducted on frame sawing machines with narrow-kerf saws are considerably larger than values given in the literature. Furthermore, in the whole range of changes of feed per tooth, the specific cutting resistance per unit of the length of the cutting edge is practically invariable. It is also significantly smaller than the specific cutting resistance per unit of the active length of the minor cutting edge, especially in the range of both small feeds per tooth and narrower kerfs.

Keywords: wood cutting; multi-point cutting; narrow-kerf saw blades; cutting resistance; frame sawing machine

### Badania eksperymentalne właściwego powierzchniowego oporu skrawania podczas przecinania piłami cienkimi

#### Streszczenie

W pracy przedstawiono wyniki badań eksperymentalnych właściwego oporu skrawania podczas przecinania drewna cienkimi piłami. W eksperymencie przyjęto wartości wejściowe: rozwarcie całkowite ostrzy (rzaz), posuw na ostrze oraz grubość brzeszczotu piły. Oprócz zmiany całkowitego przekroju warstwy skrawanej uwzględniano również wpływ warunków tarcia pomiędzy brzeszczotem piły, ścianami rzazu oraz pomocniczymi powierzchniami przyłożenia. Wyniki badań wykazały, że dla procesu przecinania na pilarkach ramowych z użyciem cienkich pił, z niewielkimi rzazami, wartości właściwego powierzchniowego oporu skrawania są znacznie większe w porównaniu z danymi literaturowymi. Ponadto, w całym zakresie zmiany wartości posuwu na ostrze właściwy powierzchniowy opór skrawania przypadający na jednostkę długości głównej krawędzi skrawającej jest praktycznie stały. Oprócz tego jest on znacząco mniejszy od właściwego powierzchniowego oporu skrawania przypadającego na jednostkę długości czynnej pomocniczej krawędzi skrawającej, szczególnie w zakresie małych wartości posuwu na ostrze oraz dla małych wartości rzazów.

Słowa kluczowe: skrawanie drewna, skrawanie narzędziem wielostrzowym, cienkie piły, właściwy powierzchniowy opór skrawania, pilarka ramowa

Address: Kazimierz A. ORŁOWSKI, D. Sc., Eng., Gdansk University of Technology, Faculty of Mechanical Engineering, Department of Manufacturing Engineering and Automation, ul. G. Narutowicza 11/12, 80-952 Gdańsk, Poland, e-mail: korlowsk@pg.gda.pl

## Nomenclature

- $A_{DT}$  – total cross-sectional area of the cut of the saw blade,  $\text{mm}^2$   
 $E_c$  – cutting energy, J  
 $E_f$  – feeding energy, J  
 $\bar{F}_c$  – mean value of the cutting force in machine cycle of the saw frame, N  
 $\bar{F}_{cw}$  – mean value of the cutting force in the working stroke, N  
 $H_p$  – workpiece height, mm  
 $H_{RP}$  – stroke of the saw frame, mm  
 $N_z$  – number of saw teeth being in contact with the kerf bottom  
 $P$  – tooth pitch, mm  
 $\bar{P}_c$  – mean value of cutting power, kW  
 $\bar{P}_{cT}$  – mean value of the main driving system total power, kW  
 $\bar{P}_{cw}$  – mean value of cutting power in the working stroke, kW  
 $\bar{P}_i$  – mean value of idling power, kW  
 $S_t$  – theoretical kerf (overall set, uncut chip width), mm  
 $a_p$  – depth of cut, mm  
 $e_c$  – specific cutting energy per unit material volume,  $\text{Jm}^{-3}$   
 $\bar{f}_z$  – mean value of feed per tooth, mm  
 $k_c$  – specific cutting resistance,  $\text{N/mm}^2$   
 $k_{c\mu}$  – specific-frictional cutting resistance,  $\text{N/mm}^2$   
 $k_{cS}$  – specific cutting resistance on the cutting edge,  $\text{N/mm}^2$   
 $k'_{cS}$  – specific cutting resistance on the minor cutting edge,  $\text{N/mm}^2$   
 $k''_{cS}$  – cutting resistance per unit of the active length of the cutting edge,  $\text{N/mm}^3$   
 $k'''_{cS}$  – cutting resistance per unit of the active length of the minor cutting edge,  $\text{N/mm}^3$   
 $n$  – number of saw blades in the gang  
 $n_{RP}$  – number of the saw frame strokes, 1/min  
 $s$  – saw blade thickness, mm  
 $v_f$  – feed speed, m/min  
 $\bar{v}_c$  – mean value of cutting speed, m/s  
 $\alpha_f$  – tool side clearance angle, °  
 $\alpha'_f$  – minor cutting edge clearance angle, °

- $\gamma_f$  – tool side rake angle, °  
 $\gamma'_f$  – minor cutting edge rake angle, °  
 $\kappa'_f$  – minor cutting edge angle, °  
 $\rho_s$  – cutting edge radius, mm

## 1. Introduction

Sawing machines constitute some of the most important machine tools in the primary and secondary production especially in the wood industry. Furthermore, they also play a significant role in the preparation of raw materials in a machine shop. In metal cutting common types of cut-off machines include reciprocating saws, horizontal endless band saws, universal tilt frame band saws and cold saws [1, 2]. However, in wood industry circular saws, band saws with either vertical or horizontal orientation of the saw blade, and sash gang saws (frame sawing machines) are mainly used [3]. The latter seemed to be obsolete until the narrow-kerf (thin) cut technologies emerged [4, 5]. The development of modern sash gang saws was stimulated by both good quality raw material shortage and producers of thin lamellar from kiln blocks and friezes for engineered wood such as glulam, engineered flooring, cants for window sashes, parts for doors and stairs, etc., who tend to increase raw material yield. The users of thin cut technologies expect the reduction of the kerf to cause a drop in cutting power requirements whereas Orlicz [6] states that the kerf reduction causes an increase in the cutting resistance. Furthermore, this statement does not give any explanation and there is no data for the determination of the specific cutting resistance for narrow-kerf saws.

No studies have been found dealing with the effect of the kerf reduction upon specific cutting resistance. This paper presents a methodology for the cutting resistance determination in the function of: mean value of feed per tooth (uncut chip thickness), the nominal kerf (overall set [7], uncut width of chip) and saw blade thickness in the case of wood re-sawing on modern sash gang saws. Moreover, distribution of the specific cutting resistance on three cutting edges of the tooth (cutting edge and two minor cutting edges) is performed. Although, this article describes phenomena regarding an example of wood sawing, the presented methodology of cutting resistance determination and its distribution on cutting edges is valid for multi-toothed cutting processes in general, for example, metal cut-off on band saws or milling with a slotting cutter.

## 2. Theoretical background

### 2.1. General remarks

Theoretical and experimental determination of values of forces acting in the cutting process belongs to the basic and simultaneously the most developed field of mechanics of this process. A great number of theoretical works, which were improved and experimentally verified, have been devoted to this problem. However, coefficients existing in many models which describe cutting forces, even for the free orthogonal cutting, have a confounded character and as a result they are of not much practical use [2, 8, 9].

In Kaczmarek's opinion [9] specific cutting energy per unit material volume  $e_c$  is the most characteristic and sensitive factor in cutting. On the other hand, assuming that cutting energy  $E_c \gg E_f$  (feeding energy) and additionally time increment  $\Delta t$ , in which an analysis is conducted, is constant, there is equality regarding values of both specific cutting energy per unit material volume  $e_c$  and specific cutting resistance  $k_c$  [10-13]. This statement has a great practical significance [8, 9]. As a result of that energetic effects (cutting forces and cutting power) are calculated on the basis of the specific cutting resistance  $k_c$  (cutting force per unit area of cut [9-12]), which is in the case of wood cutting the function of the following factors: wood species, cutting direction angle (cutting edge position in relation to wood grains), moisture content, wood temperature, tooth geometry, tooth dullness, chip thickness and some others which are less important [3, 6, 14-16]. It is well known that the value of cutting pressure depends heavily on the thickness of the cut (uncut chip thickness) [8-10], which in the case of sawing equivalent is the mean value of feed per tooth  $\bar{f}_z$  [3, 6, 13, 16-18].

For sash gang saws energetic effects such as cutting power, feed power, cutting forces and feed forces are strongly dependent upon machine tool kinematics, which affects the variation (distribution) of feed per tooth in every cycle of the saw frame movement [3, 15, 16, 19]. In modern narrow-kerf frame sawing machines for accurate wood re-sawing, kinematic systems are applied which guarantee no contact of the saw teeth with the kerf bottom [5, 20]. An example of a such kinematics of the frame sawing machine PRW15M with an elliptical trajectory of the teeth movement and the driving system dynamically balanced (designed at the Gdansk University of Technology) [19, 21] is presented in Fig. 1. Furthermore, values of the specific cutting resistance  $k_c$  given in the literature [3, 6, 14-16] are only useful for the traditional issue of frame sawing machines, since differ greatly from magnitudes for narrow-kerf re-sawing obtained in the preliminary cutting tests [22]. For that reason, the objective of this work is to analyse in detail specific cutting resistance during machining with narrow-kerf saws on the frame sawing machine PRW15M.

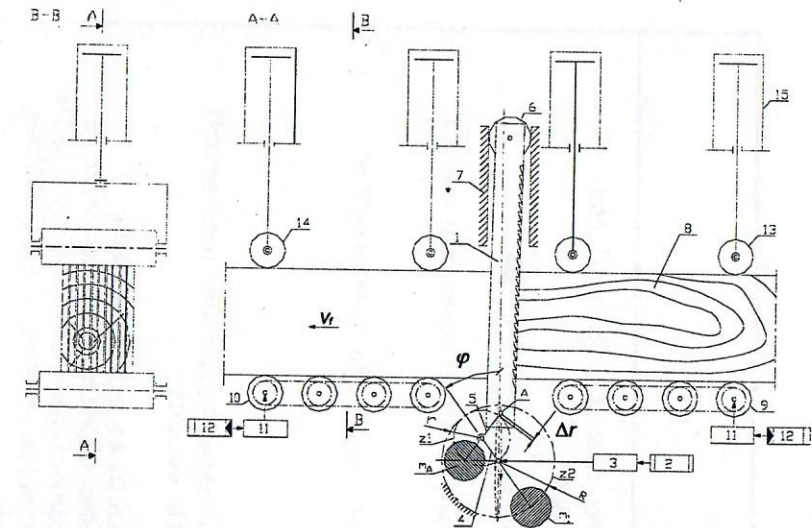

Fig. 1. Kinematic system of the frame sawing machine PRW15M, where: 1 – saw blade (saw frame), 2 – main motor, 3 – gearbox, 4 – driving arm, 5 – connecting arm, 6 – guiding rolls, 7 – guides, 8 – workpiece, 9, 10, 13, 14 – feeding rolls, 11 – gearbox of feeding system, 12 – feeding motor, 15 – air-operated cylinder;  $\Delta r$  – ellipse small radius,  $r + \Delta r$  – ellipse large radius,  $z_1, z_2$  – toothed wheels,  $m_A$  – accumulator,  $m_1$  – counterweight,  $\varphi$  – angle of rotation

### 2.2. Methodology of cutting resistance determination

On the assumption that every saw tooth of the plain shape is symmetrical and sharp, and may have contact with the kerf bottom only during the working stroke of the saw frame  $\perp$  (Fig. 1), and moreover, the feed per tooth has an uniform distribution in this stroke, the value of the specific cutting resistance may be determined on the basis of the mean cutting power experimental magnitude  $\bar{P}_c$  (Fig. 2):

$$\bar{P}_c = \bar{P}_{cT} - \bar{P}_i \quad (1)$$

The mean cutting power  $\bar{P}_c$  in the saw frame machine cycle, which consists of the working stroke and the idle stroke of the saw frame may be described as:

$$\bar{P}_c = \frac{\bar{F}_c \cdot \bar{v}_c}{1000} \quad (2)$$

where the mean value of cutting speed  $\bar{v}_c$  is calculated from:

$$\bar{v}_c = \frac{2H_{RP} \cdot n_{RP}}{60 \cdot 1000} \quad (3)$$

Since the cutting process takes place in the working stroke, therefore the cutting power in that stroke is  $\bar{P}_{cw} = 2\bar{P}_c$  (Fig. 2) and the mean value of the cutting force in the working stroke  $\bar{F}_{cw}$  can be determined by the following formula:

$$\bar{F}_{cw} = 2\bar{F}_c = k_c \cdot A_{DT} \cdot n \quad (4)$$

where:  $A_{DT}$  – total cross-sectional area of the cut of the saw blade, which for a practical purpose according to Orlicz [6] may be evaluated from:

$$A_{DT} = \sum_{i=1}^{N_z} A_D = \bar{f}_z \cdot S_t \cdot \frac{H_p}{P} \quad (5)$$

and the mean value of feed per tooth is calculated as:

$$\bar{f}_z = \frac{1000 \cdot v_f \cdot P}{n_{RP} \cdot H_{RP}} \quad (6)$$

Taking into account Eqs (2)-(6) after recalculation the following equation is obtained:

$$k_c = \frac{6 \cdot 10^4 \cdot \bar{P}_c}{n \cdot H_p \cdot S_t \cdot v_f} \quad (7)$$

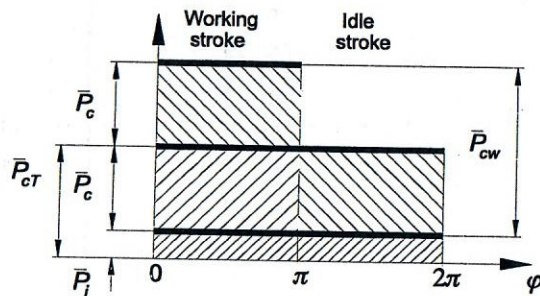

Fig. 2. Cutting powers in the saw frame machine cycle (working stroke + idle stroke)

If the mean value of the cutting power  $\bar{P}_c$  presented in Eq. (7), as distinct from a classical approach to specific cutting resistance on frame sawing machines [3, 6, 14], is determined not only as a function of the mean feed per tooth  $\bar{f}_z$  but first of all, as that of the overall set (kerf)  $S_t$  and a saw blade thickness  $s$ . In that case except for the changes of the total area of the cut the effect of friction conditions between a saw blade, kerf walls, and flanks would be considered. Hence, in order to distinguish the mentioned feature of cutting resistance from coefficients given in the literature it is postulated to call this parameter as specific – frictional cutting resistance  $k_{c\mu}$ . In consequence Eq. (7) assumes the following form:

$$k_{c\mu} = \frac{6 \cdot 10^4 \cdot \bar{P}_c (\bar{f}_z, S_t, s)}{n \cdot H_p \cdot S_t \cdot v_f} \quad (8)$$

### 3. Material and methods

Experimental investigation was carried out on the frame sawing machine PRW15M (Fig. 3). Specifications of the machine tool:  $n_{RP} = 685$  1/min,  $H_{RP} = 162$  mm,  $v_f = 0.2 - 0.5 - 1.0 - 1.5 - 2.0$  m/min,  $n = 5$  number of saws in the gang. Tests were conducted on the basis of an individual experiment design.

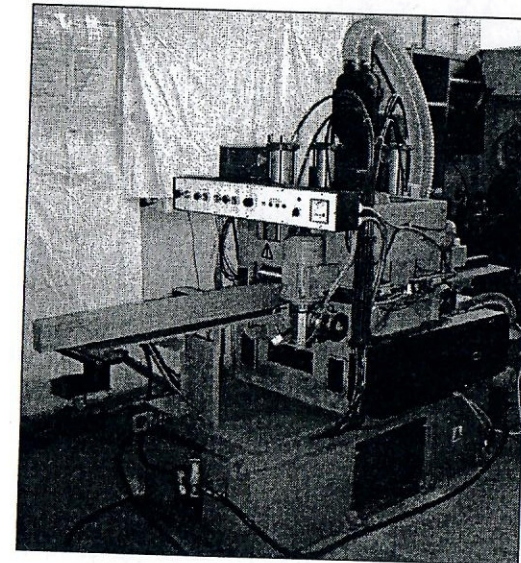

Fig. 3. Frame sawing machine PRW15M

Data of saw blades with stellite tipped teeth which were applied in tests:  $S_t = 1.25 - 1.4 - 1.7 - 2$  mm, saw blade thickness  $s = 0.8 - 0.9 - 1$  mm, a free length of the saw blade  $L_0 = 318$  mm, saw blade tension stresses  $\sigma_N = 300$  MPa, blade width  $b = 30$  mm, tooth pitch  $P = 13 - 15$  mm, tool side rake angle  $\gamma_f = 9^\circ$ , tool side clearance angle  $\alpha_f = 14^\circ$ . Blocks made of pine of  $H_p = 90$  mm with moisture content of 10.1–18.2% were cut. The above mentioned data was the set of input values and the average value of the cutting power  $\bar{P}_c$  was the output value. The cutting power was measured with a power transducer. The mean value of the idling power  $\bar{P}_i$  was determined directly before a cutting test.

## 4. Results and discussion

### 4.1. Specific-frictional cutting resistance

Specific – frictional cutting resistance was computed on the basis of the mean cutting power experimental values  $\bar{P}_c$  with the use of the CADEX: SPECTRA Software [23]. It should be emphasised that the character of cutting power alterations was linear and simultaneously in terms of quality compatible with variation courses for frame sawing machine kinematics in the traditional issue [14, 20]. On the grounds of the obtained experimental results a regression equation of the specific – frictional cutting resistance  $k_{c\mu}$  was formulated:

$$k_{c\mu} = \frac{1}{-0.00633 + 0.0151S_t + 0.00958s + 0.0662\bar{f}_z - 0.00358S_t^2 - 0.00987s^2 - 0.0185\bar{f}_z^2} \quad (9)$$

Characteristic approximation errors of Eq. (9) were as follows: multiple correlation coefficient  $R = 0.834$ ; maximal error  $\Delta z_{max} = 28$ , average error  $d = 6.64$  and mean square error  $M = 9.01$ .

Changes of the specific – frictional cutting resistance  $k_{c\mu}$  are shown in Fig. 4 and Fig. 5. The obtained results have confirmed the results of the preliminary tests [22] and they differ from values found in the literature [3, 6, 14, 15]. On the surfaces performing variations of the specific – frictional cutting resistance  $k_{c\mu}$  the minimum of it for the value of the average feed per tooth of  $\bar{f}_z = 0.17$  mm is present, by analogy to classic frame saw blades, for which it is observed for  $\bar{f}_z \cong 0.7$  mm [14]. It is supposed that for values up to  $\bar{f}_z \leq 0.17$  cutting conditions on minor cutting edges are responsible for the cutting resistance increase, but for larger values of the feed per tooth the cutting

conditions on the cutting edge play a decisive role. Additionally, by increasing the kerf value for the gullet area being constant, more chips are produced and simultaneously more of them are relocated between the saw blade and kerf walls. Furthermore, an increase in the cutting resistance observed for smaller values of the feed per tooth is characteristic of the same case as that of circular sawing [17] or bandsawing [18].

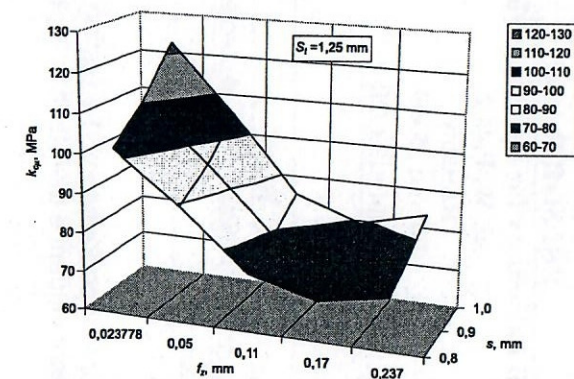

Fig. 4. Specific – frictional cutting resistance  $k_{c\mu} = f(s, \bar{f}_z)$  during re-sawing process of pine blocks of height of  $H_p = 90$  mm on the frame sawing machine PRW15-M with stellite tipped saws ( $S_t = 1.25$  mm)

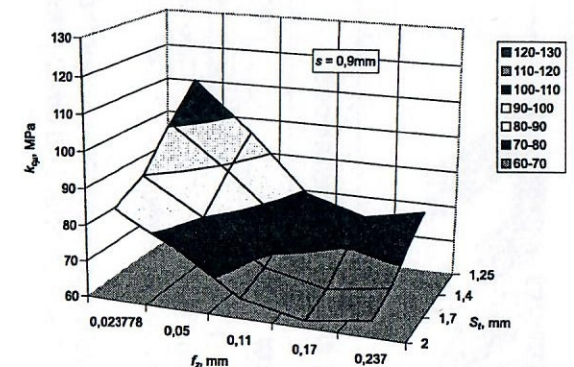

Fig. 5. Specific – frictional cutting resistance  $k_{c\mu} = f(S_t, \bar{f}_z)$  during re-sawing process of pine blocks of height of  $H_p = 90$  mm on the frame sawing machine PRW15-M with stellite tipped saws ( $s = 0.9$  mm)

Since sawing is performed with relatively small feed per tooth values (small chip thickness), this behaviour explains the large  $k_{c\mu}$  values. Moreover, for small values of the feed per tooth when its values slightly exceed the value of the cutting edge radius  $\rho_s$  ( $\bar{f}_z = a_p \approx \rho_s$ ) in the case of wood sawing there could be a situation similar to metal cutting, where cutting resistance consists of two components. The first of them plays a role only for small values of the thickness of the cut. This component for higher values of thickness of the cut is insignificant and the component being a function of the shear angle performs the main role. The shear angle becomes larger if the thickness of the cut increases, however, values of shear angle are not easy to determine in practice [2, 8]. The above mentioned phenomenon is accompanied by a reduction of the cutting resistance [8-11, 18]. Atkins [8] explains the existence of larger values of the cutting resistance for small values of feed as „a scale effect”. Nevertheless, during sawing the kerf is formed not only by one cutting edge, but by three simultaneously cutting edges (in the case of the plain tooth). Every cutting edge is characterized by different cutting conditions which are determined by differences in tooth geometry (Fig. 6) and different locations in relation to wood fibres (Fig. 7). For the cutting edge there is a case of perpendicular cutting and there are conditions of longitudinal – transverse cutting for minor cutting edges [6, 20]. In connection with this situation on every saw tooth cutting edge there appears different values of specific cutting resistances.

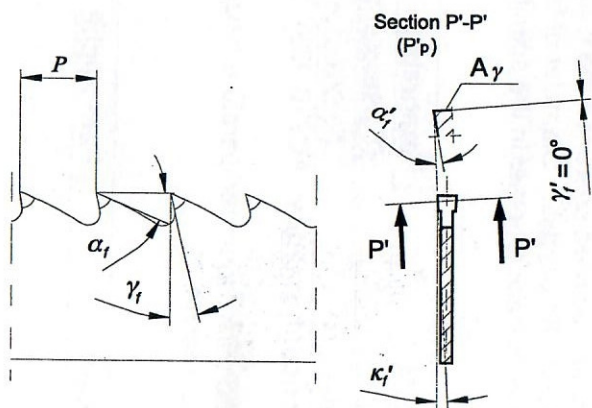

Fig. 6. Tooth geometry of a frame saw blade. Where:  $A_\gamma$  – face,  $P$  – pitch,  $\alpha_f$  – tool side clearance angle,  $\gamma$  – tool side rake angle,  $\alpha_f'$  – tool minor cutting edge clearance angle,  $\kappa_f'$  – tool minor cutting edge angle,  $\gamma_f'$  – tool minor cutting edge rake angle

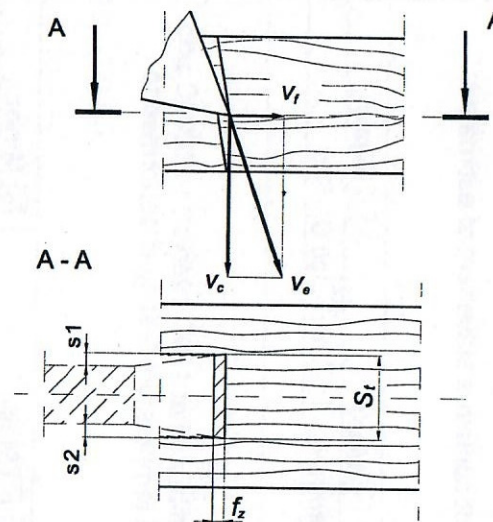

Fig. 7. Orientation of cutting edges in relation to wood fibres, geometric and kinematic quantities of sawing, where:  $v_e$  – resultant speed,  $s_1$  – set left,  $s_2$  – set right

#### 4.2. Distribution of specific – frictional cutting resistance on tooth edges

If  $\bar{f}_z > \rho_s$ , it may be assumed that the total specific – frictional cutting resistance  $k_{c\mu}$  is the sum of the specific cutting resistance on the cutting edge  $k_{cS}$  and the specific cutting resistance on minor cutting edges  $k'_{cS'}$ :

$$k_{c\mu} = k_{cS} + 2 \cdot k'_{cS'} \quad (10)$$

The specific – cutting resistance  $k_{c\mu}$  is precisely connected with the length of the cutting edge (overall set, kerf –  $S_t$ , see Fig. 5), therefore Eq. (10) may be rewritten as:

$$k_{c\mu} = k'_{cS} \cdot S_t + 2k''_{cS'} \cdot \bar{f}_z \quad (11)$$

where:  $k'_{cS} = \frac{k_{cS}}{S_t}$  – cutting resistance per unit of the active length of the cutting edge,  $N/mm^3$ ;  $k''_{cS'} = \frac{k'_{cS'}}{\bar{f}_z}$  – cutting resistance per unit of the active length of the minor cutting edge,  $N/mm^3$ .

Evaluation of the specific cutting resistance per unit of the active length of both the cutting edge and the minor cutting edge is possible only in the range of input values used in the tests. On the assumption that  $\bar{f}_z = \text{const.}$  and the right and left sets  $s_1 = s_2 = \text{const.}$  (Fig. 7), values of the specific – frictional cutting resistance  $k_{c\mu}$  are calculated from Eq. (9) for different values of the saw blade thickness  $s \in (0.8; 1.0)$ . Eventually, values of  $k'_{cs}$  and  $k''_{cs}$  are calculated from the system of linear equations formed on the basis of the Eq. (11).

Values of the specific cutting resistance per unit of the length of the cutting edge  $k'_{cs}$  are graphically shown in Fig. 8. Figure 9 presents magnitudes of the specific cutting resistance per unit of the active length of the minor cutting edge  $k''_{cs}$ .

The carried out distribution of the specific – frictional cutting resistance proves that the main cause of the cutting resistance increase on frame sawing machines, during re-sawing with narrow-kerf saws at the small values of feed per tooth, are adverse cutting conditions present on tooth minor cutting edges. The latter arises mainly from small values of the tool minor cutting edge rake angle  $\gamma'_f = 0^\circ$  and also the clearance angle  $\alpha'_f \approx 3^\circ$ , which is roughly equal to the tool minor cutting edge angle  $\kappa'_f$  (Fig. 6). Thus, large values of the specific cutting resistance per unit of the length of the minor cutting edge  $k''_{cs}$  accompany this phenomenon (Fig. 9). This explanation may also be used when analysing metal bandsawing phenomena, in which kinematics of the process is different. Nevertheless, for plain teeth, which are similar in the shape to swaged teeth, the character of cutting is similar.

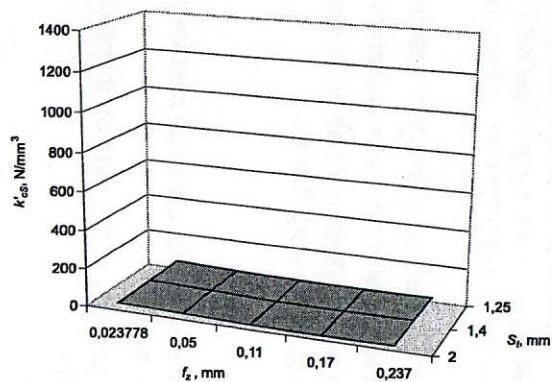

Fig. 8. Specific cutting resistance per unit of the length of the cutting edge  $k'_{cs}$  during re-sawing process of pine blocks of height of  $H_p = 90$  mm on the frame sawing machine PRW15-M with satellite tipped saws (saw blade thickness  $s \in (0.8; 1.0)$ )

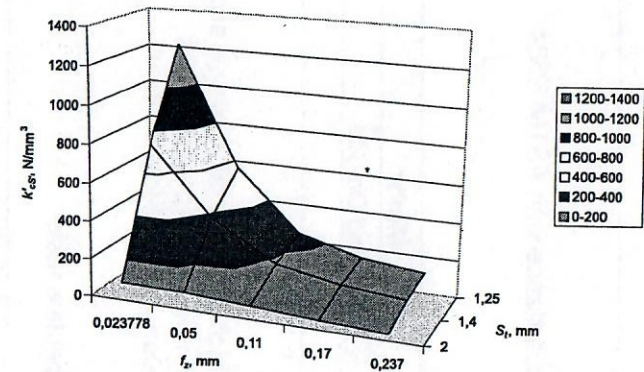

Fig. 9. Specific cutting resistance per unit of the length of the minor cutting edge  $k''_{cs}$  during re-sawing process of pine blocks of height of  $H_p = 90$  mm on the frame sawing machine PRW15-M with stellite tipped saws (saw blade thickness  $s \in (0.8; 1.0)$ )

## 5. Conclusions

Obtained experimental results and carried out theoretical analyses have revealed the following:

- Values of the specific cutting resistance for re-sawing process conducted on frame sawing machines with narrow-kerf saws are considerably larger than values given in the literature. It may be expected that analogous phenomena can accompany the cut-off processes with saws (circular sawing machines, band saws, reciprocating saws) independently of a kind of sawn material if kerf reduction occurs.

- In the whole range of changes of the feed per tooth  $\bar{f}_z$ , the specific cutting resistance per unit of the length of the cutting edge  $k'_{cs}$  is practically invariable. Furthermore, it is significantly smaller than the specific cutting resistance per unit of the active length of the minor cutting edge  $k''_{cs}$ , especially in the range of both small feeds per tooth and narrower kerfs.

- In order to distinguish the discussed in this study parameter of cutting resistance from coefficients given in the literature it is postulated to call it specific – frictional cutting resistance  $k_{c\mu}$ , for the reason that the latter takes into account not only changes of the total area of the cut, but also the effect of friction conditions between a saw blade, kerf walls and flanks.

### Acknowledgements

This research has been supported by the State Committee for Scientific Research in Poland as the 7 T07D 01217 research grant. The author is pleased to acknowledge MFLS Forezienne (France) for the saw blade preparation for the needs of the individual test design, GASS Sp. z o.o., Suwalki (Poland) and AKE Knebel (Germany) for providing mini gang saw blades for supplementary tests.

### References

- [1] P.F. OSTWALD, J. MUNOZ: Manufacturing processes and systems. John Wiley and Sons, Inc., 1997.
- [2] TAE JA KO, HEE SOOL KIM: Mechanistic cutting force model in band sawing. *International Journal of Machine Tools & Manufacture*, **39**(1999)8, 1185–1197.
- [3] J. LISIČAN et al.: Teoria a technika spracovania dreva. Matcentrum, Zvolen 1996.
- [4] J. LEMPELIUS: Thin boards have a high value. *European Woodworking, Holz-Zentralblatt* (2005), 42–44.
- [5] K. ORŁOWSKI, W. PRZYBYLSKI, R. WASIELEWSKI: Frame sawing machines for accurate wood re-sawing. Proc. of the 16<sup>th</sup> Int. Wood Machining Seminar, Matsue, Japan 2003, Matsue: Fac. Sci. a. Eng., Shimane Univ., vol. 1 Oral presentations, 248–256.
- [6] T. ORLICZ: Obróbka drewna narzędziami tnącymi. Skrypty SGGW-AR w Warszawie, Wydawnictwo SGGW-AR, Warszawa 1988.
- [7] PN-93/D-01008 (idt ISO 7294: 1983). Uzębienia pił do drewna. Zarys kształtu. Terminologia i oznaczenie.
- [8] A.G. ATKINS: Modelling metal cutting using modern ductile fracture mechanics: quantitative explanations for some longstanding problems. *Journal of Mechanical Sciences*, **45**(2003), 373–396.
- [9] J. KACZMAREK: Podstawy obróbki wiórowej, ścierniej i erozyjnej. Wydawnictwa Naukowo-Techniczne, Warszawa 1970.
- [10] W. GRZESIK: Podstawy skrawania materiałów metalowych. WNT, Warszawa 1998.
- [11] K. JEMIELNIAK: Obróbka skrawaniem. Oficyna Wydawnicza Politechniki Warszawskiej, Warszawa 1998.
- [12] PN-92/M-01002/04 (idt ISO 3002-4). Podstawowe pojęcia w obróbce wiórowej i ścierniej. Siły, energia i moc.
- [13] F. SCHOLZ, J. TROEGER: Modelling of cutting forces. Proc. of 17<sup>th</sup> Int. Wood Machining Seminar, Yuri Stakhiev Seminar, G. Lachenmayr and F. Scholz (ed.), Rosenheim 2005, Germany, University of Applied Sciences, Retru-Verlag e.K., Weyarn, Part 2: Posters, Cutting Process, 260–264.
- [14] A.I. AGAPOV: Dinamika processa pilenija drevesiny na lesopil'nych ramach. Kirovskij Politechničeskij Institut. Izd. GGU, Gor'kij 1983.
- [15] F.A. BOGDANOV, I.P. OSTROUMOV: Podgotovka i ekspluatacija ramnych pil. Lesnaja Promyšlennost', Moskva 1986.
- [16] G.F. PROKOFIEV: Intensifikacija pilenija drevesiny ramnymi i lentočnymi pilami. Lesnaja Promyšlennost', Moskva 1990.

- [17] B. ETTTEL, H.J. GITTEL: Sägen, Fräsen, Hobeln, Bohren. Die Spannung von Holz und ihre Werkzeuge, DRW-Verlag Weinbrenner GmbH & Co.KG, 2004.
- [18] C. ANDERSSON, J.-E. STÅHL, H. HELLBERGH: Bandsawing. Part II: detecting positional errors, tool dynamics and wear by cutting force measurement. *Journal of Machine Tools and Manufacture* **41**(2001), 237–253.
- [19] R. WASIELEWSKI: Pilarki ramowe z eliptyczną trajektorią prowadzenia pił i hybrydowym wyrównoważonym dynamicznie układem napędu głównego. Monografia nr 10, Wydawnictwo Politechniki Gdańskiej, Gdańsk 1999.
- [20] K. ORŁOWSKI: Materiałoszczędne i dokładne przecinanie drewna piłami. Seria Monografie nr 40, Wydawnictwo Politechniki Gdańskiej, Gdańsk 2003.
- [21] R. WASIELEWSKI, K. ORŁOWSKI: Hybrid dynamically balanced saw frame drive. *Holz als Roh- und Werkstoff*, **60**(2002), 202–206.
- [22] K. ORŁOWSKI, R. WASIELEWSKI, W. BLACHARSKI: Effects of workpiece thickness and a kind of a saw blade on the cutting power during sawing on the frame sawing machine. Proc. of the 1<sup>st</sup> Int. Conf.: Sawing and Machining of Wood Materials. The Effect of Workpiece on the Parameters of a Cutting Process, Brno 1998. Mendel Univ. of Agriculture and Forestry, Faculty of Forestry and Wood Technology, 23–28.
- [23] R. GÓRECKA: Teoria i technika eksperymentu. Politechnika Krakowska, Kraków 1998.

Received in May 2007