

## Hydraulic Loss Coefficients in 1D Flows

Jerzy M. Sawicki

Gdańsk University of Technology, Faculty of Civil and Environmental Engineering,  
ul. G. Narutowicza 11/12, 80-952 Gdańsk, Poland, e-mail: jsaw@pg.gda.pl

(Received December 13, 2006; revised March 30, 2007)

### Abstract

Determination of hydraulic losses is a very important problem, both from the cognitive and practical points of view. For the uniform and steady fluid streams these losses are described by the well known algebraic expressions, containing some experimental coefficients. In technical practice it is commonly assumed, that these coefficients can be applied also for more complex kinds of flow (non-uniform and even unsteady). However, the problem analysis shows that the proper level of conformity between the results of calculations and measurements can be obtained only after a considerable enlargement of the loss coefficient. Investigation of available characteristics of non-uniform and unsteady 1D velocity fields, presented in this article, leads to the conclusion that this enlargement is physically justified and in some cases it is possible to determine correction factors, which enable recalculation of “basic” coefficients into their new values, suitable for more complex models of 1D flows.

**Key words:** hydraulic loss, closed-conduits flows, water hammer, open-channels flow

### Notation

The following symbols are used in this paper:

- $a_c, a_p$  – velocity of disturbance propagation (for open-channel and pipe respectively);
- $A$  – auxiliary parameter;
- $B$  – stream width;
- $C$  – Chézy coefficient;
- $d, D$  – pipe diameter;
- $[D]$  – strain rate tensor;
- $D_{ij}$  – components of strain rate tensor;
- $e$  – internal energy;
- $f$  – auxiliary value;
- $\mathbf{f}$  – unit mass force;
- $F$  – Froude number;
- $Fr, Fb$  – auxiliary functions;

- $g$  – gravity acceleration;  
 $h$  – water depth;  
 $h_L$  – local energy loss;  
 $h_R$  – longitudinal energy loss;  
 $H_m$  – maximal pressure head;  
 $H_0$  – initial pressure head;  
 $i, j$  – indices of coordinates ( $i, j = x, y, z$ );  
 $i_{fc}, i_{fp}$  – friction slope (for open-channel and pipe respectively);  
 $i_0$  – bottom slope;  
 $I_C, I_S$  – auxiliary functions;  
 $J_0, J_1$  – Bessel functions of zero- and first-order respectively;  
 $k$  – auxiliary index;  
 $K$  – empirical coefficient;  
 $L$  – length;  
 $M$  – auxiliary function;  
 $n$  – Manning coefficient of roughness;  
 $N$  – power of energy dissipation;  
 $p$  – pressure;  
 $P$  – drag force;  
 $q_L$  – lateral inflow;  
 $Q$  – discharge of water;  
 $r$  – radius;  
 $R$  – pipe radius;  
 $R_H$  – hydraulic radius;  
 $Re$  – Reynolds number;  
 $S$  – stream cross-section area;  
 $S_M$  – auxiliary variable;  
 $t$  – time;  
 $T$  – temperature;  
 $\mathbf{u}$  – velocity;  
 $\mathbf{v}_C$  – velocity of body;  
 $v$  – mean velocity;  
 $V_C$  – volume of body;  
 $x, y, z$  – Cartesian coordinates;  
 $\alpha$  – angle;  
 $\alpha_s$  – coefficient of virtual mass;  
 $\beta$  – empirical coefficient of thermoelastic energy loss;  
 $\Delta$  – finite difference; Laplace operator;  
 $\varepsilon$  – thermal conductivity;  
 $\zeta_D$  – coefficient of local energy loss, calculated as for longitudinal resistance;  
 $\zeta_L$  – coefficient of local energy loss (experimental);



- $\lambda$  – corrected value of hydraulic loss coefficient;  
 $\lambda_S$  – hydraulic loss coefficient for steady and uniform flow;  
 $\mu$  – dynamic coefficient of fluid viscosity;  
 $\mu_T$  – dynamic coefficient of turbulent viscosity;  
 $\nu$  – kinematic coefficient of fluid viscosity;  
 $\nu_T$  – kinematic coefficient of turbulent viscosity;  
 $\rho$  – fluid density;  
 $\sigma$  – auxiliary parameter;  
 $\tau$  – auxiliary time variable;  
 $\tau_{0c}, \tau_{0p}$  – shear stress (for open-channel and pipe respectively);  
 $\varphi_c, \varphi_p$  – correction factor for hydraulic loss coefficient (for open-channel and pipe respectively);  
 $\chi$  – root of the equation;  
 $\omega$  – frequency.

## 1. Introduction

The family of simplified models of the fluid flows consists of a considerable number of different variants. A category of 1D models plays an especially important role. From the practical point of view one can distinguish two main groups of technical systems – open-channels and closed-conduits.

The problems of the first group, in the general non-uniform and unsteady case, can be described by the classical Saint-Venant equations, which can be written in the following form (Chow 1952, Sawicki 1987):

$$\frac{\partial h}{\partial t} + \frac{\partial(vh)}{\partial x} = q_L, \quad (1)$$

$$\frac{\partial v}{\partial t} + v \frac{\partial v}{\partial x} + g \frac{\partial h}{\partial x} = g(i_0 - i_{fc}). \quad (2)$$

For the closed conduits in turn we can use the equations (Puzyrewski and Sawicki 2000):

$$\frac{\partial(\rho S)}{\partial t} + \frac{\partial(\rho S v)}{\partial x} = 0, \quad (3)$$

$$\frac{\partial v}{\partial t} + v \frac{\partial v}{\partial x} + \frac{1}{\rho} \frac{\partial p}{\partial x} = g(i_0 - i_{fp}), \quad (4)$$

where the friction slopes (for open-channels and pipes respectively) are defined by the following expressions:

$$i_{fc} = \frac{\tau_0}{\rho g R_H}, \quad i_{fp} = \frac{4\tau_0}{\rho g D}. \quad (5)$$



The shear stress  $\tau_0$ , according to Newton's hypothesis, is combined with the normal derivative of the fluid velocity component, parallel to the boundary. However, in 1D models, when we do not describe the inner structure of the flow, this factor has been expressed by an algebraic term, containing an empirical coefficient of hydraulic losses. This fact has some important consequences, as the viscous term in the fluid flow governing equations has *a diffusive form* (i.e. contains second derivatives of velocity), whereas this algebraic term acts as *a source function* (Abreu and Almeida 2000, Sawicki and Wichowski 2001).

In technical handbooks one can find different expressions, describing the shear stress  $\tau_0$ . Probably the most typical are the following:

- for open-channels (Chow 1952):

$$\tau_{0c} = \frac{\rho g v^2}{C^2}, \quad (6)$$

- for closed-conduits (Puzyrewski and Sawicki 2000):

$$\tau_{0p} = \lambda \frac{g v^2}{8}. \quad (7)$$

Both formulas (6) and (7) have been derived for uniform and steady flows many decades ago. However, they still play a very important role in practice. Moreover, these expressions are formally simple and convenient, so in some moment somebody assumed that it could be very attractive to apply them also for non-uniform and steady flows, when:

$$v = v(x), \quad p = p(x), \quad h = h(x), \quad (8)$$

and even for non-uniform and unsteady flows, when:

$$v = v(x, t), \quad p = p(x, t), \quad h = h(x, t). \quad (9)$$

This assumption has been accepted for many years. However, during recent years it was experimentally stated that the results of calculations, carried out for "traditional" values of the hydraulic loss coefficient ( $\lambda$  or  $n$ , or equivalent), do not agree with the results of precise measurements. There exist a serious number of technical papers devoted to this question (Axworthy et al 2000, Brunone et al 1991, Zielke 1968). Some of them present practical models of a friction stress in fluid streams. An interesting classification of these models can be found in the paper (Bergant et al 2001). According to this suggestion we can distinguish the friction factor models:

- depending on the mean flow velocity;
- depending on the mean flow velocity and its local acceleration;



- depending on the mean flow velocity and its accelerations (local and advective);
- depending on the mean flow velocity and the diffusive term (second spatial derivative of velocity);
- depending on the mean flow velocity and its past changes (weighed in some different ways);
- depending on the instantaneous velocity profile.

The concept presented below belongs to the first class of the friction factor models.

## 2. Hydraulic Loss Coefficients for Complex 1D Flows – Traditional Attitude

### 2.1. General Remarks

There exist three important aspects of hydraulic models of flow:

- time-dependence (which yields two categories of motion – unsteady and steady);
- space-dependence (giving two cases – uniform and non-uniform motion);
- technical features (mainly: closed-conduits and open-channels).

Taking them into account, the problem considered in this paper should be discussed systematically for four different classes of flow:

- unsteady pipe flow;
- unsteady open-channel flow;
- steady but non-uniform pipe flow;
- steady but non-uniform open-channel flow.

### 2.2. Unsteady Pipe Flow

As the most typical case of the considered phenomenon one should recognize the water hammer. Especially spectacular evidence of the above mentioned discrepancy was found during the investigation of this kind of flow.

The problem can be illustrated by means of Figs. 1 and 2, where the envelopes of the overpressure head:

$$\Delta H_m(t) = \text{abs} [H_m(t) - H_0], \quad (10)$$

during the water hammer are shown, for two pipes – made of steel and PVC. There are three lines in each figure. A continuous one shows the envelope of the results of measurements, presented in the paper (Mitosek 1997), a dashed one shows the envelopes of numerical solution to the Eqs. (3) and (4) (Wichowski 1999), obtained for the “classical” value of  $\lambda_S$ , and a dotted line showing the envelopes of solutions for the corrected coefficient  $\lambda = 30 \lambda_S$ . Analyzing these diagrams one can easily state that the significant correction of the loss coefficient is really necessary.



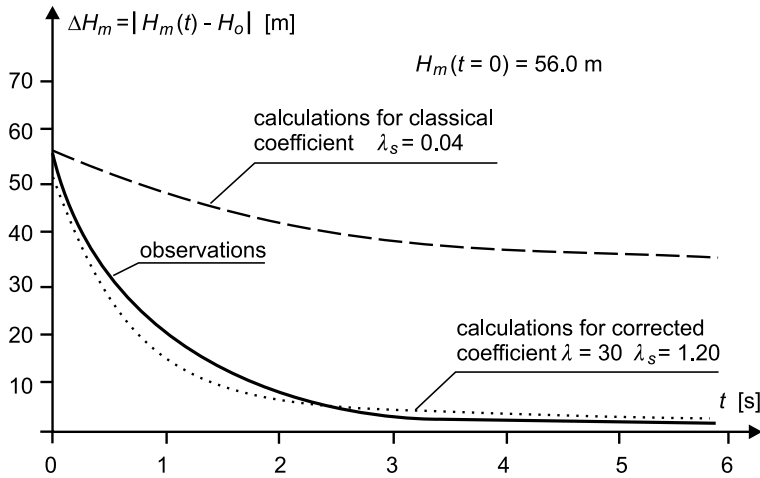

Fig. 1. Envelopes of the pressure fluctuations during the water hammer (steel pipe)

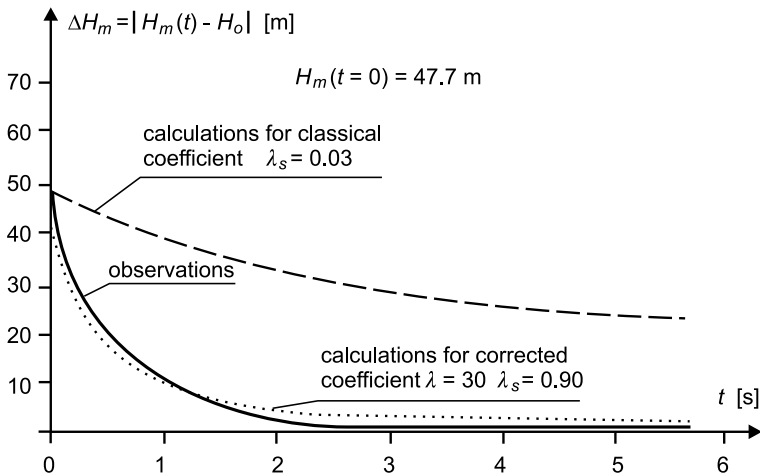

Fig. 2. Envelopes of the pressure fluctuations during the water hammer (PVC pipe)

### 2.3. Unsteady Open-Channel Flow

This very wide category of technical problems includes such important kinds of flow as the propagation of the flood waves.

Comparing the effects of numerical simulations with the results of measurements, one can observe a similar regularity – the proper level of conformity between calculations and observations can be obtained after correction of the “traditional” coefficient of roughness (Kveton and Dusicka 2005, Piwecki et al 1986).

Initially, this fact was put down to the methodological inaccuracies (description of the channel bed, formulation of the initial and boundary conditions, numerical

errors etc.), but in the light of the analogous effect observed in other classes of 1D models of flow, it would be purposeful to discuss also this phenomenon.

#### 2.4. Non-Uniform and Steady Pipe Flow

It is an evident statement that pipelines cross-sections are usually constant. For this reason non-uniform (although steady) flows in this category of technical objects are observed rather seldom. As typical examples of this kind of pipelines one could mention a diffuser (diverging pipe) and confuser (converging pipe). However, in practice, the length by such an elements is rather short and usually they are treated as pipe fittings. In consequence, the mechanical energy loss, caused by such an element, has the character of a local factor and can be calculated from the classical expression:

$$h_L = S_{LI} \frac{v_I^2}{2g} = S_{LT} \frac{v_T^2}{2g}, \quad (11)$$

where indices  $I$  and  $T$  show that the coefficient can be related both to the initial ( $I$ ) and terminal ( $T$ ) cross sections.

In order to assess the influence of the determination of the loss coefficient on the energy drop, let us use the second possible model – the technical generalization of Darcy-Weisbach formula, according to which (see Fig. 3):

$$dh_R = \lambda_S \frac{8Q^2}{\pi g d^5(x)} dx, \quad (12)$$

where  $\lambda_S$  should be calculated by means of commonly known hydraulic methods (especially: Nikuradse diagram or Colebrook-White formula). Generally this value varies along the non-uniform stream, but for fully developed turbulent flow it does not depend on the Reynolds number. In the evaluation presented below it was assumed that  $\lambda_S = \text{const}$  (Puzyrewski and Sawicki 2000).

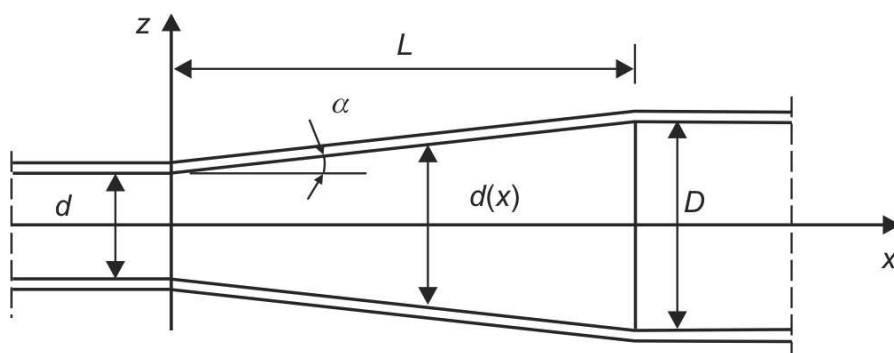

Fig. 3. Schematic diagram of a diffuser (diverging pipe)



The total energy loss for this case can be calculated by integration of Eq. (12):

$$h_R = \int_0^L dh_R. \quad (13)$$

For a diffuser we can write:

$$d(x) = d + 2x \tan \alpha. \quad (14)$$

Substituting Eqs. (12) and (14) into Eq. (13) and comparing the results of integration with Eq. (11), one can obtain the coefficient of local energy loss, expressed by the coefficient  $\lambda_S$ :

$$\zeta_{ID} = \frac{\lambda_S}{8 \tan \alpha} \left[ 1 - \left( \frac{d}{D} \right)^4 \right], \quad \zeta_{DT} = \frac{\lambda_S}{8 \tan \alpha} \left[ \left( \frac{D}{d} \right)^4 - 1 \right]. \quad (15)$$

If the traditional assumption, respecting the generalization of the loss coefficient, had been acceptable, we would have obtained the identity:

$$\zeta_{DI} = \zeta_{LI}, \quad \zeta_{DT} = \zeta_{LT}. \quad (16)$$

However, a simple calculation shows that this condition is not fulfilled. Using experimental values of  $\zeta_{LI}$ , determined by Lencaster (Walden and Stasiak 1971), we can calculate corrected values of  $\lambda$  which would fulfill the condition (16), which means that:

$$\lambda \left( \frac{D}{d}, \alpha \right) = \frac{8 \tan \alpha}{1 - \left( \frac{d}{D} \right)^4} \zeta_{LI}. \quad (17)$$

The results are shown in Fig. 4. As is seen there, also in this case one should use much higher coefficients of hydraulic loss (about 30 times), in order to obtain a conformity between theoretical calculations and technical measurements.

## 2.5. Non-Uniform and Steady Open-Channel Flow

Venturi flumes can probably serve as the best example of this category of fluid motion. Such objects are very willingly applied in technical practice, especially to measure the discharge of sewer treatment plants. The most typical solutions in this case are critical-depth Venturi flumes.

In order to obtain a properly designed shape of the water-free-surface in this flume, one should make use of the steady version of Eq. (2):

$$\frac{dh(x)}{dx} = \frac{i_0 - i_{fc}}{1 - F^2}, \quad (18)$$





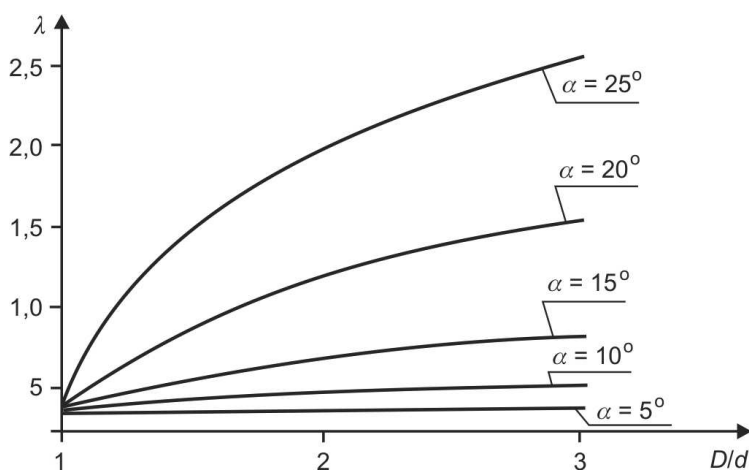

Fig. 4. Correction factor for diffusers (Eq. (17))

where the Froude number:

$$F = \frac{v}{\sqrt{gh}}. \quad (19)$$

As it results from practical calculations, also in this case the conformity between the theory and observations can be reached only for the increased value of the resistance coefficient. The Venturi flume can deliver a good example of this case (Sawicki 2001, Polak 2005) – in order to obtain the equivalence of calculated (Eq. 18) and measured free-surface profiles, one has to increase the resistance coefficient (by about 50–100%).

### 3. Description of Mechanical Energy Losses for the Flowing Fluid

#### 3.1. Significance of the Stream Walls

Considering deformability of the stream walls, one can observe a huge difference between closed-conduits and open-channels. For the first group of these technical problems the flexibility of walls is limited, so damping of the flow disturbances energy is caused by the fluid itself and by the wall material (mainly steel, cast iron, plastics or concrete). According to the traditional attitude, this factor has been described by elastic models for both these media. In consequence, the pressure wave velocity during the water hammer is expressed as follows:

$$a_p = \frac{1}{\sqrt{\rho \left( \frac{1}{E_c} + \frac{D}{r_s E_s} \right)}}. \quad (20)$$



However, in this way we can describe only one element of the influence of these walls – deformability. The second important element, viz. energy dissipation in the wall material, is not comprised by this model.

One has to remember that mechanisms of this dissipation in each of two considered media are completely different. In the flowing fluid we have to do with the viscous transfer of energy, whereas in the wall material – with the relaxative conversion of the mechanical energy into its thermal form (see Fig. 5).

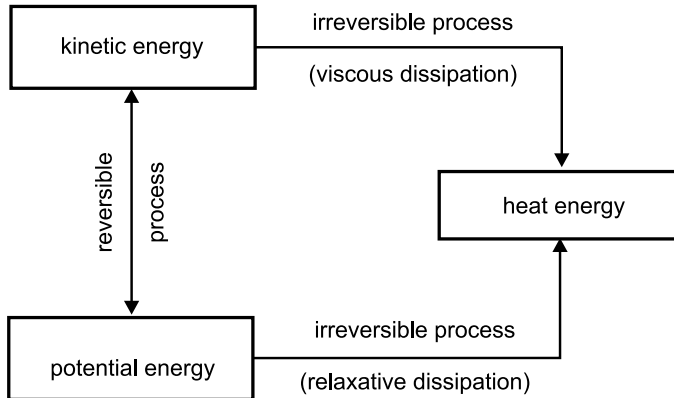

Fig. 5. Energy conversion during the fluid flow

If so, the total energy dissipation  $N_{dis}$  (viscous in the fluid  $N_v$  and relaxative in the wall material  $N_r$ ) could be expressed by the following relation (Sawicki and Wichowski 2001):

$$N_{dis} = N_v + N_r = \lambda \frac{v^2}{2D} + 2\beta \left| \frac{\partial H}{\partial t} \right|. \quad (21)$$

Talking about the second group of the considered technical problems, viz. open-channels, we must remember that the flexibility of the stream bed is practically close to zero (because of the Earth's crust scale), but the upper element of the stream perimeter – namely free-surface – does not practically exhibit any resistance against the water vertical motion. In effect, the velocity of flow disturbances propagation depends on the actual depth only (Chow 1952):

$$a_c = \sqrt{gh}. \quad (22)$$

Let us note that these differences in the expected intensity of disturbances energy damping find their reflection in the already discussed differences of the loss coefficients correction factors. These factors are much higher for the pipe flows (see the previous section) than for open-channels.

### 3.2. Thermal Conversion of Mechanical Energy

Viscous damping comprises two basic processes – transfer of mechanical energy in space and its conversion into heat energy. The first element has a diffusive character, whereas the second one acts as a source function. In consequence of the energy diffusion, the amplitude of disturbance decreases, together with the increase of its period. The source conversion of energy in turn causes only the drop of this amplitude. Both these factors are present in the equation of momentum conservation (Puzyrewski and Sawicki 2000):

$$\rho \frac{D\mathbf{u}}{Dt} = \rho \mathbf{f} - \nabla p + \mu \Delta \mathbf{u} \quad (23)$$

and in the equation of energy conservation, which can be written in the following form (including the equation of entropy balance):

$$\rho \frac{De}{Dt} = N_{dis} + \frac{p}{\rho} \frac{D\rho}{Dt} + \varepsilon \Delta T, \quad (24)$$

where the dissipative source of entropy:

$$N_{dis} = \mu \left\{ 4(D_{xy}^2 + D_{yz}^2 + D_{zx}^2) + \frac{2}{3}(D_{xx} - D_{yy})^2 + \frac{2}{3}(D_{xx} - D_{zz})^2 + \frac{2}{3}(D_{yy} - D_{zz})^2 \right\} \quad (25)$$

and  $D_{ij}$  ( $i, j = x, y, z$ ) denotes the components of the strain rate tensor:

$$D_{ij} = \frac{1}{2} \left( \frac{\partial u_i}{\partial x_j} + \frac{\partial u_j}{\partial x_i} \right). \quad (26)$$

The above relations quantitatively describe considered processes – reversible conversion of kinetic and potential energy (with a simultaneous change of the fluid density) and irreversible conversion of kinetic energy into its thermal form (although without any relaxative effects), together with the spatial diffusion of kinetic and thermal energy. The 1D model takes into account only the source dumping of the mechanic energy.

### 3.3. Possibilities of 1D Model Perfection

All the physical factors discussed show the simplicity of 1D models of the fluid flow. And among the simplifying assumptions one should seek possibilities of improvement of this tool. Practical comparison of theoretical results and experimental data should be the decisive argument for (or against) such improvements, but equally important are functional aspects of the considered equations.



From the formal point of view, eventual improvement of the existing models can be reached doubly:

- changing the form of these equations;
- keeping these relations in their present form.

The above distinction is of very important meaning. One should remember that the theoretical simulations of more complex fluid flows are carried out by numerical methods in technical practice. The number of commercial computer programmes, used by the specialists, is very serious. If the change of the governing equations form was necessary, all these programmes would be useless. Such a situation would be very attractive for the producers of software, but probably the present owners would not be delighted. This group of specialists would be interested in the second formal possibility – viz. in the maintaining of the present state (assuming that this state would have strong theoretical rudiments). The analysis of this question is the main goal of this article.

## **4. Correction of the Loss Coefficients**

### **4.1. Theoretical Premises**

According to the most correct attitude towards the considered problem, we should determine the shear stress  $\tau_0$ , using Newton's hypothesis, and then – calculate the loss coefficient by comparing the obtained relation with Eq. (6) or Eq. (7) respectively.

However, determination of real velocity fields could be possible in a limited number of rather simple cases (e.g. Hagen-Poiseuille solution for a circular pipe, Couette flow for two parallel walls). In the other cases one would be forced to use numerical methods, leading to approximate solutions – time-consuming, rather expensive and having rather limited general value.

More purposeful would be the application of the available information – solutions to the governing equations or evaluations of such solutions. This attitude has been chosen underneath.

### **4.2. Unsteady Flow in Closed-Circuits**

The number of analytical solutions to the unsteady equations of the fluid flow is not very high. Moreover, these solutions are related to very simple cases of flow – in regular systems and laminar. But it would be much better to obtain even a simplified evaluation of the resistance coefficient, than to be satisfied with its intuitive and purely experimental value.

An interesting solution of the considered flow category has been presented by Slezkin (Lojczanskij 1973). This solution describes a velocity field in a horizontal pipe, induced by a suddenly applied pressure drop:



$$\frac{\Delta p}{L} = \text{const.} \tag{27}$$

Longitudinal velocity profile  $u_x(r, t)$  can be expressed as follows (Lojczanski 1973, page 458, see also Fig. 6):

$$u_x(r, t) = \frac{R^2 \cdot \Delta p}{4\rho\nu L} \left[ 1 - \frac{r^2}{R^2} - 8 \sum_{k=1}^{\infty} \exp\left(-\frac{\nu\chi_k^2 t}{R^2}\right) \frac{J_0\left(\chi_k \frac{r}{R}\right)}{\chi_k^3 J_1(\chi_k)} \right], \tag{28}$$

where  $J_0$  is the Bessel function and  $\chi_k$  are the roots of the equation:

$$J_0(\chi_k) = 0. \tag{29}$$

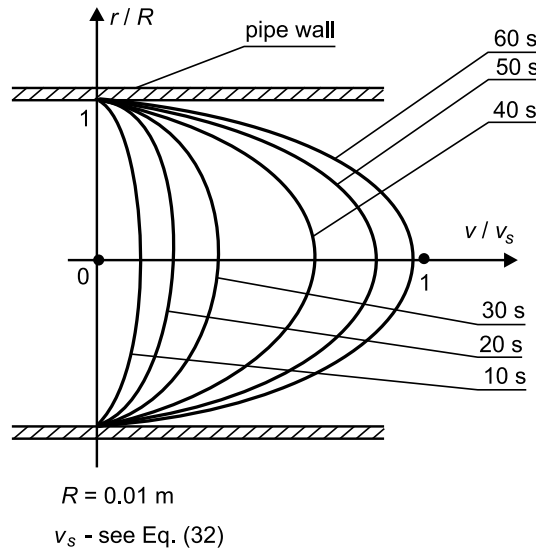

**Fig. 6.** Velocity profiles for the unsteady flow described by Eq. (28)

The mean velocity along the pipe equals (Lojczanski 1973):

$$v(t) = \frac{1}{S} \int_S u_x(r, t) dS = \frac{\Delta p R^2}{8\rho\nu L} (1 - S_M), \tag{30}$$

where:

$$S_M(t) = 32 \sum_{k=1}^{\infty} \frac{\exp\left(-\frac{\nu\chi_k^2 t}{R^2}\right)}{\chi_k^4}. \tag{31}$$

One can easily find out that for the increasing time ( $t \rightarrow \infty$ ) the time-dependent mean velocity  $v(t)$  tends on the terminal value, identical with that given by the classical Hagen-Poiseuille solution:

$$v_s = \frac{\Delta p R^2}{8\mu L}. \quad (32)$$

Rearranging the Eq. (30) we can write:

$$\Delta p = \frac{64\nu}{v_s D [1 - S_M(t)]} \frac{L \rho v^2(t)}{2}. \quad (33)$$

Using more traditional symbols:

$$\Delta p = \frac{\lambda_s}{1 - S_M(t)} \frac{L \rho v^2(t)}{2}, \quad (34)$$

we obtain a generalized version of the Darcy-Weisbach formula, where  $\lambda_s$  is a steady-state coefficient of hydraulic loss (e.g. after Nikuradse).

It is clear that the time-dependent coefficient  $\lambda(t)$ :

$$\lambda(t) = \frac{\lambda_s}{(1 - S_M)^2}, \quad (35)$$

is apparently greater than its traditional steady version (Fig. 7), which confirms the experimentally stated conclusion, discussed in this article.

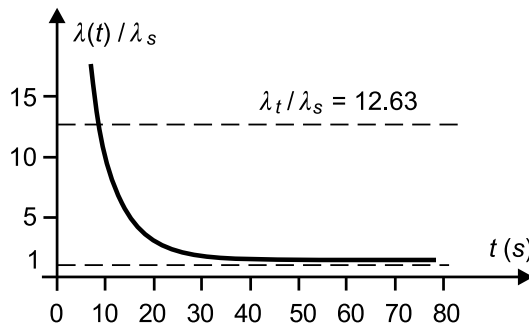

Fig. 7. Correction factor for the unsteady flow described by Eq. (35)

However the practical application of the function given by the Eq. (35) would be in contradiction with the main premise of this paper, viz. theoretically justified multiplication of a constant hydraulic loss coefficient. In order to find such a parameter, a mean value  $\lambda_T$  of the function  $\lambda(t)$  was determined. Necessary calculations were performed using numerical methods (because of the mathematical form of the considered functions), which yielded:

$$\frac{\lambda_T}{\lambda_S} = 12.63. \quad (36)$$

It is necessary to underline that this value practically does not depend on the technical parameters of flow (pressure drop, pipe diameter and length).

In order to obtain more information about the problem discussed, another available analytical solution has been considered, viz. the oscillating flow along a horizontal pipe, caused by the harmonic variation of the pressure drop:

$$\frac{\Delta p(t)}{L} = \frac{\Delta p_m}{L} \cos(\omega t). \quad (37)$$

This solution to the fluid-flow equations has the following form (Lojczanskij 1973):

$$u_x(r, t) = \frac{\Delta p_m}{\rho L \omega} \left\{ \sin(\omega t) \left[ 1 - F_b \text{bei} \left( r \sqrt{\frac{\omega}{\nu}} \right) - F_r \text{ber} \left( r \sqrt{\frac{\omega}{\nu}} \right) \right] + \right. \\ \left. + \cos(\omega t) \left[ F_b \text{ber} \left( r \sqrt{\frac{\omega}{\nu}} \right) + F_r \text{bei} \left( r \sqrt{\frac{\omega}{\nu}} \right) \right] \right\}, \quad (38)$$

where:

$$F_b = \frac{\text{bei}(A)}{\text{ber}^2(A) + \text{bei}^2(A)}, \quad (39)$$

$$F_r = \frac{\text{ber}(A)}{\text{ber}^2(A) + \text{bei}^2(A)}, \quad (40)$$

$$A = R \sqrt{\frac{\omega}{\nu}}. \quad (41)$$

Two symbols –  $\text{ber}(f)$  and  $\text{bei}(f)$  – denote the Kelvin functions, i.e. the real and imaginary parts of the Bessel function  $J_0(f\sqrt{i})$ , and can be expressed by the following infinite series:

$$\text{ber}(f) = 1 - \frac{f^4}{2^2 4^2} + \frac{f^8}{2^2 4^2 6^2 8^2} - \dots, \quad (42)$$

$$\text{bei}(f) = \frac{f^2}{2^2} - \frac{f^6}{2^2 4^2 6^2} + \frac{f^{10}}{2^2 4^2 6^2 8^2 10^2} - \dots \quad (43)$$

Examples of the considered velocity profiles are shown in Fig. 8.

Repeating the procedure applied above for Eq. (28), we can calculate the mean flow velocity  $v(t)$ , which is expressed by the following formula:

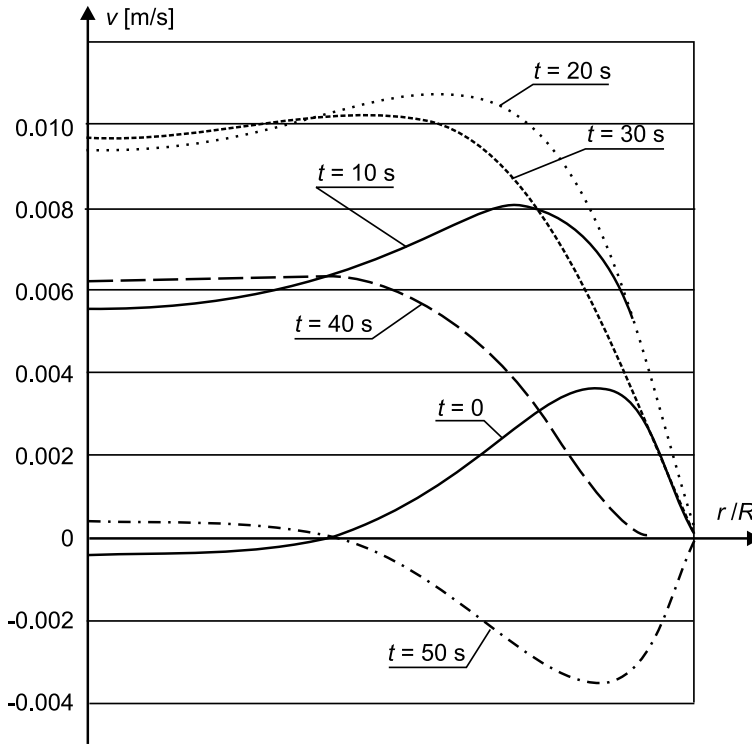

Fig. 8. Velocity profiles for the unsteady flow described by Eq. (38)

$$v(t) = \frac{\Delta p R^2}{\rho L \nu} [I_S \sin(\omega t) + I_C \cos(\omega t)] = \frac{\Delta p R^2}{8 \mu L} M, \quad (44)$$

where:

$$I_S = \int_0^R \left[ 1 - F_b \text{bei} \left( r \sqrt{\frac{\omega}{\nu}} \right) - F_r \text{ber} \left( r \sqrt{\frac{\omega}{\nu}} \right) \right] dr, \quad (45)$$

$$I_C = \int_0^R \left[ F_b \text{ber} \left( r \sqrt{\frac{\omega}{\nu}} \right) + F_r \text{bei} \left( r \sqrt{\frac{\omega}{\nu}} \right) \right] dr, \quad (46)$$

$$M(t, \omega) = I_S \sin(\omega t) + I_C \cos(\omega t). \quad (47)$$

Rearranging Eq. (44) we obtain (see Eqs. (33) and (34)):

$$\Delta p = \frac{\lambda_S}{M(t, \omega)} \frac{L \rho v^2(t)}{D^2}, \quad (48)$$



which means, that in the considered case we have the following relation, describing the time-dependent hydraulic loss coefficient:

$$\lambda(t) = \frac{\lambda_S}{M(t, \omega)} = \varphi_p \lambda_S. \quad (49)$$

The correction factor  $\varphi_p$  is a function of time  $t$  and a non-dimensional parameter:

$$\sigma = R^2 \frac{\omega}{\nu}. \quad (50)$$

An example of the numerically determined absolute value of the function  $\lambda(t)/\lambda_S$  is shown in Fig. 9.

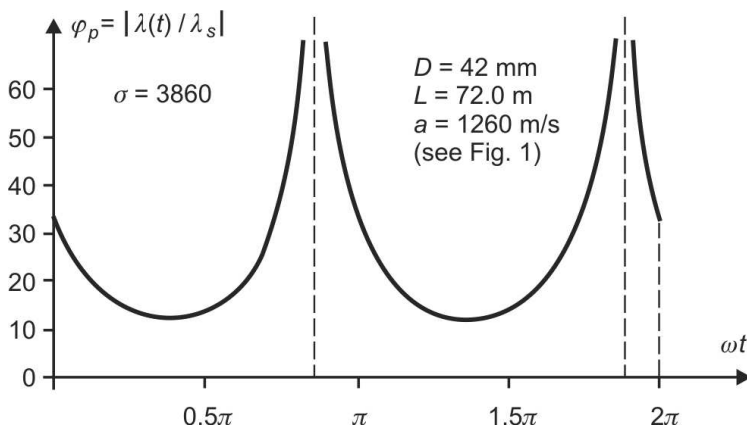

**Fig. 9.** Time-dependent correction factor for the unsteady flow described by Eq. (49)

Also in this case (see Eq. (35) and Fig. 7) the actual value of  $\lambda(t)$  tends to infinity when the mean velocity  $v$  tends to zero (as the indeterminacy  $0 \cdot \infty$  should give a finite value of the pressure drop – Eqs. (34) and (48)).

According to our procedure (see Eq. (36)) we should determine the time-averaged value of the correction factor  $\varphi_c$ . Numerical calculations lead to the conclusion that the considered correction factor is a function of  $\sigma$  and  $D/L$  (Fig. 10).

Now we can compare the obtained relation with the empirically stated correction factor  $\varphi_p$ . For the case shown in Fig. 1 (steel pipe) we have  $\sigma = 3860$ . Using the Fig. 9 we have the value  $\varphi_{pe} = 18$ . Considering a plastic pipe in turn (Fig. 2 –  $\sigma = 4020$ , as  $D = 45.2$  mm,  $L = 27.0$  m,  $a_c = 425$  m/s) we obtain  $\varphi_p = 19$ .

In both cases we have a surprisingly good similarity, as the experimental value was equal to  $\varphi_{pe} = 20$ .



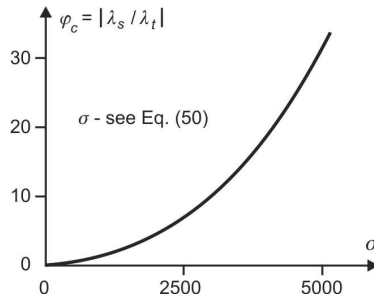

**Fig. 10.** Time-averaged correction factor for the unsteady flow described by Eq. (49)

### 4.3. Non-Uniform Flow Through Diffuser

In order to discuss the considered problem of the correction of the coefficient  $\lambda_s$  in the next flow category, let us make use of the results obtained previously (Fig. 4), which enable us to determine the corrected loss coefficient for the “diffuser-type” systems. However, this result has only a cognitive sense. From the practical point of view this case is not very interesting, as long diffusers (or confusers) rather seldom appear in hydraulic systems. Usually these elements are treated as local pipe fittings. But in fact, the main goal of considerations presented in this section was to show that also in this case the “steady-value” of  $\lambda_s$  should be increased.

### 4.4. Non-Uniform and Unsteady Open-Channel Flows

Regular shapes of the closed conduits gave us possibility to evaluate correction factor  $\varphi_p$  for two already considered cases (Fig. 8). Alas, the open-channel flows are much more complex, so we are not able to determine proper velocity fields which could be discussed.

In this situation one can use a general expression (Eq. (25)), which defines a power of mechanical energy dissipation (i.e. its conversion into heat energy). An important feature of the considered 1D non-uniform and unsteady flows in open channels is longitudinal variation of the main component of the fluid velocity, which can be replaced by its mean value:

$$u_x(x, y, z, t) \approx v(x, t). \quad (51)$$

This means that the unit power of dissipation (i.e. related to the fluid volume) can be presented as a sum of two factors:

$$N_d = N_{dl} + N_{dv}. \quad (52)$$

The first one takes into account non-uniformity of the flow, and according to Eq. (26) can be written as follows (for the turbulent motion):



$$N_{dl} = \frac{4}{3} \mu_T \left[ \frac{\partial v(x, t)}{\partial x} \right]^2. \quad (53)$$

Other terms in Eq. (25) are responsible for the “transversal” dissipation  $N_{dv}$ , which appear always (due to the transversal variation of velocity). In the technical practice these terms are usually calculated by means of the Chézy formula (Chow 1952), which yields:

$$N_{dv} = \frac{\rho g v^2}{C^2 h}. \quad (54)$$

If so, we can rewrite Eq. (52), obtaining:

$$N_d = \frac{\rho g v^2}{C^2 h} + \frac{4}{3} \mu_T \left[ \frac{\partial v}{\partial x} \right]^2. \quad (55)$$

According to this formula we can state that the non-uniform and unsteady dissipation is always more intensive than its “uniform” part, which qualitatively confirms our experimental conclusions, mentioned above.

In order to derive more quantitative relations, let us make use of the continuity equation, which for the open-channel flows has the form (Puzyrewski and Sawicki 2000):

$$\frac{\partial S}{\partial t} + \frac{\partial(vS)}{\partial x} = 0. \quad (56)$$

After simple rearranging we can write:

$$\frac{\partial v}{\partial x} = -\frac{1}{S} \frac{\partial S}{\partial t} - \frac{v}{S} \frac{\partial S}{\partial x}, \quad (57)$$

which enables us to rewrite Eq. (53) as follows:

$$N_{dl} = \frac{4}{3} \frac{\mu_T}{S^2} \left( \frac{\partial S}{\partial t} + v \frac{\partial S}{\partial x} \right)^2. \quad (58)$$

Dividing Eq. (52) by  $N_{dv}$  (Eq. (54)) we obtain an evaluation of the hydraulic loss correction factor for the considered open-channel flows:

$$\varphi_c = 1 + \frac{N_{dl}}{N_{vl}} = 1 + \frac{4C^2 h}{3B^2 g Re_0 v_0^2} \left( \frac{\partial S}{\partial t} + v \frac{\partial S}{\partial x} \right)^2. \quad (59)$$

The obtained formula is not simple enough to be applied in practice, but for those cases where we would be able (at least approximately) to describe the variation of the stream cross-section  $S(x, t)$ , it could be useful.



As an example let us consider a steady flow in a Venturi-flume, mentioned above. The gradient of its cross-section can be evaluated as follows:

$$\frac{\partial S}{\partial x} \approx \frac{h_0 B_0 - h_g B_g}{L}. \quad (60)$$

The Reynolds number for the initial cross-section of the flume equals:

$$Re_0 = \frac{Q}{B_0 \nu_T} = \frac{v_0 h_0}{\nu_T}. \quad (61)$$

The coefficient of turbulent viscosity can be calculated from the relation (Lauder and Spalding 1972):

$$\mu_T = 0.016 v_0 h_0. \quad (62)$$

For the first case (FG1) we have (Sawicki 2001):  $Q = 0.60 \text{ m}^3/\text{s}$ ,  $h_0 = 0.75 \text{ m}$ ,  $B_0 = 1.47 \text{ m}$ ,  $h_g = 0.35 \text{ m}$ ,  $B_g = 0.74 \text{ m}$ ,  $L = 1.30 \text{ m}$ ,  $v_0 = 0.54 \text{ m/s}$ ,  $\mu_T = 0.00648 \text{ m}^2/\text{s}$ ,  $Re_0 = 63$ ,  $C^2 = 2660 \text{ m/s}^2$ , so the Eq. (63) gives us:

$$\varphi_{c1} = 1.49. \quad (63)$$

For the second flume (FG2) we have:  $Q = 0.60 \text{ m}^3/\text{s}$ ,  $h_0 = 0.54 \text{ m}$ ,  $B_0 = 1.85 \text{ m}$ ,  $h_g = 0.40 \text{ m}$ ,  $B_g = 0.90 \text{ m}$ ,  $L = 1.30 \text{ m}$ ,  $v_0 = 0.60 \text{ m/s}$ ,  $\mu_T = 0.00518 \text{ m}^2/\text{s}$ ,  $Re_0 = 63$ ,  $C^2 = 1720 \text{ m/s}^2$ , which yields:

$$\varphi_{c2} = 1.17. \quad (64)$$

Also in this case, two theoretically calculated correction factors are very close to those obtained by means of experimental trial and errors method.

With a much more complex situation we can have to deal with during the unsteady flow, as the water level may vary with a very different intensity. However, analyzing the results of measurements of real flood waves, we can state that the velocity of natural changes of the water level can vary from 0.001 m/s for the small rivers (when the water discharge  $Q$  equals about 0.14 m<sup>3</sup>/s), to 0.00001 m/s for bigger rivers (when  $Q$  reaches 100 m<sup>3</sup>/s) (Kveton and Dusicka 2005, Szkutnicki 1996). This means that the influence of the flow time-variation on the correction factor  $\varphi_c$  is much weaker than that of longitudinal changes of the water level, as for the example presented above we have:

$$v \frac{\partial h}{\partial x} \approx 0.1 \text{ m/s}. \quad (65)$$

## 5. Conclusions

Resuming considerations presented in this article one can formulate the following final remarks:

1. the hydraulic loss coefficients are determined for the uniform and steady flows;
2. in the traditional attitude these coefficients are applied also for non-uniform and even unsteady 1D flows, without any corrections;
3. precise measurements show that this attitude cannot be accepted, as the effects of theoretical simulations differ from the experimental results;
4. in order to obtain an acceptable conformity between the theory and observations, one has to increase the coefficient of hydraulic loss – up to 30 times for closed-conduits and about 50–100% for open-channels; this level of correction has been determined by means of the trial and error method;
5. the important problem of the proper description of the mechanical energy dissipation is very intensively investigated; in consequence the classical forms of the governing equations of 1D fluid flow will be changed;
6. it is rather impossible to foresee the time perspective of this *eventual* change; moreover, even if this correction is introduced, *the traditional model will still be an attractive tool* in technical practice;
7. if so, the specialists, interested in mathematical simulations of 1D non-uniform and unsteady flows, would like to know answers to two important questions:
  - about the character of this experimentally stated necessity of hydraulic loss coefficients correction (is it physical, or numerical?);
  - about the practical determination of this correction;
8. analysis of some available pieces of information about the considered kinds of flow leads to the conclusion that the increase of the hydraulic loss coefficient is a physical consequence of the velocity field complexity; details of this analysis are shown in this article;
9. it is very interesting that the results of this analysis confirm the general level of the loss coefficient correction – quite high for the closed-conduits and rather moderate for the open-channels;
10. the quantitative methods of such correction, proposed in this article (see Fig. 10 for the unsteady pipe flow, Eq. (54) for the steady but non-uniform pipe flows and Eq. (63) for open-channels flows) are charged by many simplifications, but they give at least first approximations of the discussed correction factors; such an approximation is always better information than a purely intuitive multiplier.

## References

- Abreu J. M., Almeida A. B. (2000) Pressure transient dissipative effects: a contribution for their computational prediction, *Proc. of 8<sup>th</sup> Int. Conf. on Pressure Surges and Fluid Transients*, The Hague (The Netherlands), BHR Group Conf. Series No. 39.

- Armatyński M., Sawicki J. M. (2002) Determination of energy losses in unsteady flows, *Proc. of XXII School of Hydraulics* Lubniewo (Poland), IBW PAN, Gdańsk (in Polish).
- Axworthy D. H., Ghidaoni M. S., McInnis D. (2000) Extended thermodynamic derivation of energy dissipation in unsteady pipe flow, *J. Hydr. Eng.*, **4** (126).
- Bergant A., Simpson A. R., Vitkovsky J. (2001) Development in Unsteady Pipe Flow Friction Modeling, *J. of Hydraulic Research*, **3** (39).
- Brunone B., Golia U. M., Greco M. (1991) Some remarks on the momentum equation for fast transients, *Proc. of Int. Meeting on Hydraulic Transients and Water Column Separation, IAHR*, Valencia (Spain).
- Chow V. T. (1952) *Open-Channel Hydraulics*, McGraw-Hill Book Company, New York.
- Kveton R., Dusicka P. (2005) Terrain measurements and calibration of hydro-dynamical model of water work Drahovce-Madunice, *Proc. of Int. Symp. on Water Management and Hydraulic Engineering*, BOKU, Ottenstein (Austria).
- Lauder B. E., Spalding D. B. (1972) *Lectures in Mathematical Models of Turbulence*, Academic Press, New York-London.
- Loycynskiy L. G. (1973) *Fluid Mechanics*, Izdatelstvo Nauka, Moscow (in Russian).
- Mitosek M. (1997) Study of cavitation due to water hammer in plastic pipes, *J. Hydr. Eng.*, **7** (26).
- Piwecki T., Biernacki M., Sawicki J. M. (1986) A mathematical model of heat and mass transfer for an open-channel flow, *Proc. of Int. Symp. on Hydrological Processes in the Catchment* Cracow Technical University, Cracow (Poland).
- Polak U. (2005) *Determination of sewage discharge by means of throated flumes*, PhD Thesis, Cracow Technical University (in Polish).
- Puzyrewski R., Sawicki J. M. (2000) *Fundamentals of Hydromechanics and Hydraulics*, 3rd ed., PWN SA, Warsaw (in Polish).
- Sawicki J. M. (1987) Fundamental equations for free-surface turbulent plane flow, *Archiwum Hydrotechniki*, **34** (3–4).
- Sawicki J. M. (2001) Hydraulic investigations of Venturi flumes, *Arch. of Hydro-Eng. and Env. Mech.*, **48** (1).
- Sawicki J. M., Wichowski R. (2001) Simplified model of visco-relaxative energy losses in water hammer, *Proc. of 7th Symp. on Application of Fluid Mechanics in Env. Eng.*, Silesian Technical University, Wisła (Poland) (in Polish).
- Szkutnicki J. (1996). Experimental evaluation of the river roughness, *Scientific Papers: Hydrology and Oceanology*, **19**, IMGW, Warsaw (in Polish).
- Walden H., Stasiak J. (1971) *The mechanics of liquids and gases in sanitary engineering*, Arkady, Warszawa (in Polish).
- Wichowski R. (1999) Unsteady flow analysis In water supply networks, *Arch. of Hydro-Eng. and Env. Mech.*, **46** (1–4).
- Zielke W. (1968), Frequency dependent friction in transient pipe flow, *J. of Basic Engrng.*, **1** (90).

