

# INFLUENCE OF REDUNDANCY AND SHIP MACHINERY CREW MANNING ON RELIABILITY OF LUBRICATING OIL SYSTEM FOR THE MC-TYPE DIESEL ENGINE

**Roman Liberacki**

*Gdansk University of Technology  
ul. Narutowicza 11/12, 80-950 Gdańsk, Poland  
tel.: +48 58 3471850, fax: +48 58 3472430  
e-mail: romanl@pg.gda.pl*

## **Abstract**

*Influence of redundancy and ship machinery crew manning on reliability of typical lubricating oil system for the MC – type diesel engine has been considered. The results of reliability calculations for the system with redundancy and without redundancy have been presented. Moreover, three training levels of crew have been taken account in those calculations: high, average and low.*

**Keywords:** *reliability, redundancy, manning, lubricating system, diesel engine*

## **1. Introduction**

Reliability of the main engine is extremely important for ship's safety. That's why the Ship Classification Societies like: Lloyd Register of Shipping, Det Norske Veritas, Germanischer Lloyd, American Bureau of Shipping, Polish Register of Shipping etc. require redundancy in the most important systems on ships. One of them is the lubricating oil system. In practical applications pumps and filters are doubled.

Lloyd Register of Shipping rules for lubricating oil pumps are [1]:

*“Where lubricating oil for the main engine(s) is circulated under pressure, a standby lubricating oil pump is to be provided where the following conditions apply:*

*(a). The lubricating oil pump is independently driven and the total output of the main engine(s) exceeds 370 kW(500 shp).*

*(b). One main engine with its own pump is fitted and the output of the engine exceeds 370 kW (500 shp).*

*(c). More than one main engine each with its own lubricating oil pump is fitted and the output of each engine exceeds 370 kW (500 shp).*

*8.2.2. The standby pump is to be of sufficient capacity to maintain the supply of oil for normal conditions with any one pump out of action. The pump is to be fitted and connected ready for immediate use, except that where the conditions referred to in (c) apply a complete spare pump may be accepted. In all cases satisfactory lubrication of the engines is to be ensured while starting and manoeuvring.”*

For lubricating oil filters [1]:

*“Where the lubricating oil for main propelling engines is circulated under pressure, provision is to be made for the efficient filtration of the oil. The filters are to be capable of being cleaned without stopping the engine or reducing the supply of filtered oil to the engine. Proposals for an automatic by-pass for emergency purposes in high speed engines are to be submitted for special consideration.”*

The human element is also one of the most important contributory aspects to the causation and avoidance of system failures, and as the result of those failures - accidents. To produce valid results in reliability analysis it is necessary to assess the contribution of the human element to system failure. This contribution can be assessed using human reliability analysis (HRA) [2].

In a light of the above statement, the author decided to make approach to human reliability analysis in investigations.

## 2. Lubricating oil system for the MC – type diesel engine

The considered lubricating oil system, typical for the MC – type diesel engines, is shown on Fig. 1. Lubrication of engine bearings, camshaft bearings and piston cooling is carried out by the uni – lubricating oil system. Cylinder liners are lubricated by a separate cylinder lubricating oil system [3].

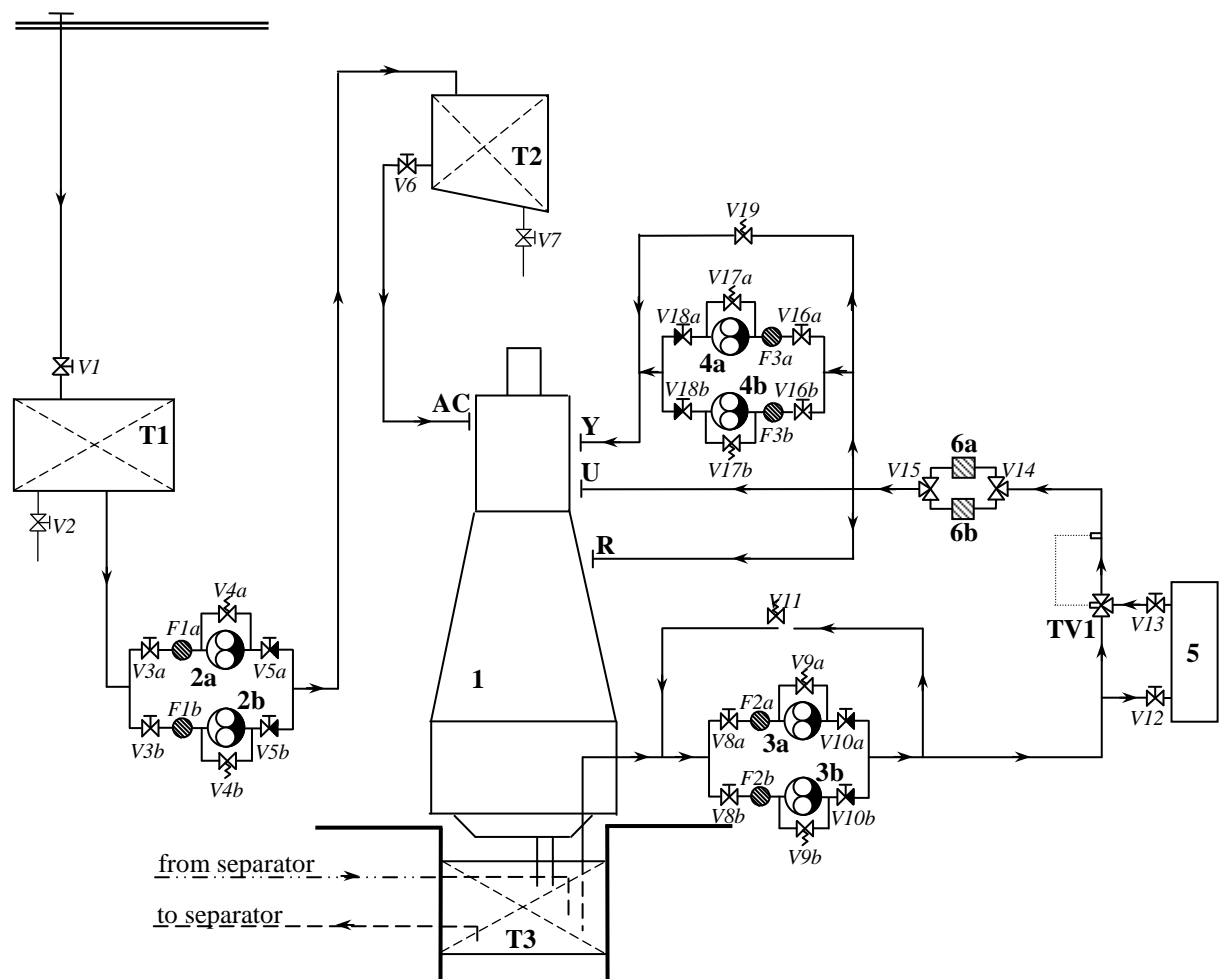

Fig. 1. Lubricating oil system for the MC – type diesel engine: 1 - diesel engine; 2a, 2b – cylinder lubricating oil transfer pumps; 3a, 3b - lubricating oil pumps; 4a, 4b – camshaft lubricating oil booster pumps; 5 – lubricating oil cooler; 6a, 6b – lubricating oil duplex filter; T1 – cylinder lubricating oil storage tank; T2 – cylinder lubricating oil service tank; T3 – lubricating oil bottom tank; TV1 – thermostatic valve; V... – valves; F... – suction filters

All the lubricating oil pumps are of the screw wheel type. The lubricating oil cooler is of the plate type heat exchanger. The duplex lubricating oil filter is installed. It has sufficient capacity to allow the specified full amount of oil to flow through each side of the filter. The oil temperature control system can, by means of a three – way valve unit, by – pass the cooler totally or partly [3].

Only the external lubricating oil system is shown on Fig. 1. The rest of the system is supplied with the engine and is called the internal lubricating oil system. Treatment of the lubricating oil for bearings is carried out by self cleaning separators.

### 3. Reliability model of the lubricating oil system

Reliability of the lubricating oil system is the probability that the system will function properly. The continuous work of the diesel engine will be possible. The reliability is a function of time, beginning at zero time. To assess the reliability of the system the fault tree method and the minimal cut sets method have been used. The minimal cut sets method is a simplified method, so the results of calculations are approximate. This method gives the lower boundary of the system reliability.

The required reliability data for technical items have been adopted from [4, 5]. The data - failure rates of selected technical items  $\lambda$  [h<sup>-1</sup>] are given in Tab. 1.

Tab. 1. Failure rates of technical items

Symbol	Item	Failure mode	Failure rate $\lambda$ [h <sup>-1</sup> ]
1	Diesel engine	-	-
2a, 2b 3a, 3b 4a,4b	Cylinder lubricating oil transfer pumps, Lubricating oil pump, Camshaft lubricating oil booster pumps	_1 - low output, _2 - fail while running, _3 - fail to start, _4 - critical leakage,	5.87E-6 55.34E-6 26.66E-6 3.46E-6
5	Lubricating oil cooler	_1 - critical leakage, _2 - insufficient cooling,	0.46E-6 ~0E-6
6a,6b	Lubricating oil duplex filter	_1 - inadmissible pressure drop, _2 - damaged mesh, _3 - critical leakage,	4.53E-6 0.12E-6 0.19E-6
T1 T2 T3	Cylinder lubricating oil storage tank, Cylinder lubricating oil service tank, Lubricating oil bottom tank,	_1 - critical leakage,	2.34E-6
TV1	Thermostatic valve	_1 - critical leakage, _2 - insufficient temp. control,	0.76E-6 2.43E-6
F1a, F1b F2a, F2b F3a, F3b	Suction filters	_1 - inadmissible pressure drop, _2 - damaged mesh, _3 - critical leakage,	4.53E-6 0.12E-6 0.16E-6
V11, V19	Regulating valves	_1 - critical leakage, _2 - insufficient pressure control,	0.76E-6 0.16E-6
V4a, V4b V9a, V9b V17a, V17b	Safety valves	_1 - critical leakage, _2 - fail to open, _3 - opens under to low pressure,	0.76E-6 0.16E-6 2.02E-6
V1, V2 V6, V7 V12, V13 V3a, V3b V8a, V8b V16a, V16b	Stop valves	_1 - critical leakage, _2 - plugged in open/close position,	0.76E-6 0.56E-6
V5a, V5b V10a, V10b V18a, V18b	Non - return stop valves	_1 - critical leakage, _2 - plugged in open/close position, _3 - back flow,	0.76E-6 0.56E-6 2.02E-6
V14, V15	Three way valves	_1 - critical leakage, _2 - plugged,	0.76E-6 0.56E-6
PI	Pipeline including sealing	_1 - critical leakage,	9E-6

The failure rates, given above, refer to calendar time. For redundant items it is necessary to take account that their active working time is only a part of the time (approximately 50 %).

The statistical reliability data in Tab.1. are mostly adopted from offshore installations. They are not fully representative for ship systems. The data have been used because it is extremely hard to get such data for ships. The achieved results of calculations based on the data are then of tentative character. Due to the data character - the exponential distribution has been used in the reliability calculations.

Technical state of system (reliability of the system) depends on human behavior. Avoiding of the machinery systems failures, especially in the sea, is a machinery crew task. Unfortunately a human being makes mistakes. That is why we should take into account a human error probability (HEP) in system reliability analysis.

Human Reliability Analysis (HRA) was developed primarily for the nuclear industry. Using HRA in other industries requires that the techniques be appropriately adapted. For example, because the nuclear industry has many built-in automatic protection systems, consideration of the human element can be legitimately delayed until after consideration of the overall system performance. Onboard ships, the human has more degrees of freedom to disrupt system performance. Therefore, a high-level task analysis needs to be considered at the outset of an Formal Safety Assessment (FSA). There are two main HRA quantitative techniques (HEART and THERP). As the data from all of these sources are based on non-marine industries, they need to be used with caution. A good alternative is to use expert judgement and one technique for doing this is Absolute Probability Judgement (APJ) [2].

The above mentioned techniques are very advanced. The preliminary human error probability assessment can be made using a very simple method ASEP - HRAP (Accident Sequence Evaluation Program - Human Reliability Analysis Procedure) published in 1987 by Swain [6]. Adaptation of the method in shipping one can find in [7]. The same method has been used in this study.

In the ASEP - HRAP technique the Basis Human Error Probability (BHEP) equals 0.03. BHEP contains both: human error of omission and human error of commission. If a potential for the error to be recovered exists, then the value of BHEP is multiplied by so called recovery factor (f) (mostly equals 0.1 or 0.01 depending on situation) [7]. Human error probabilities, taken account in model of lubricating oil system reliability, are shown in Tab. 2.:

*Tab. 2. Human error probabilities in the lubricating oil system manning*

Symbol	Human error	Human error probability
HEP_1	- no reaction or to late reaction to stop degrade of the system elements	0.03
HEP_2	- no reaction or to late reaction to an inadmissible pressure drop on a filter, (equipped with a pressure drop alarm device)	~ 0
HEP_3	- no reaction or to late reaction to inadmissible pressure drop on a filter, (not equipped with a pressure drop alarm device)	0.03
HEP_4	- no reaction or to late reaction to oil level low in a tank, (equipped with a level low alarm device)	~ 0

Three levels of crew qualification have been assumed in the model: high, average and low. According to TESEO (it. Tecnica Empirica Stima Errori Operatori) method [8, 9] the following assumptions have been made:

- for high crew qualification level the probability of human error equals 50 % of the value given in Tab. 2.,
- for low crew qualification level the probability of human error is three times higher then the value given in Tab. 2.

Additional assumptions to the model:

- the electric power supply is provided,
- the lubricating oil treatment system is efficient,
- all stop valves and non - return stop valves are opened (except V2, V7),
- all tanks are equipped with level low alarm devices,
- the lubricating oil duplex filter is equipped with a high pressure drop alarm device,
- all suction filters are not equipped with high pressure drop alarm devices,
- critical leakage means the engine has to be stopped immediately.

Lubricating oil system reliability with redundancy can be expressed as follows:

$$\begin{aligned}
 R_r(t) = & 1 - \{ HEP_{4T1} + \{ [1 - \exp(-\lambda_{V2\_1}t)] + [1 - \exp(-\lambda_{T1\_1}t)] \} \cdot HEP_{-1} + HEP_{4T2} + \{ [1 - \exp(-\lambda_{V7\_1}t)] \\
 & + [1 - \exp(-\lambda_{T2\_1}t)] \} \cdot HEP_{-1} + [1 - \exp(-\lambda_{V6\_1}t)] \cdot HEP_{-1} + \{ [1 - \exp(-\lambda_{V3a\_1}t)] + [1 - \exp(-\lambda_{V3b\_1}t)] + \\
 & [1 - \exp(-\lambda_{V5a\_1}t)] + [1 - \exp(-\lambda_{V5b\_1}t)] \} \cdot HEP_{-1} + \{ [1 - \exp(-\lambda_{F1a\_1}t)] \cdot HEP_{-3} + [1 - \exp(-\lambda_{2a\_1}t)] \cdot HEP_{-1} \\
 & + [1 - \exp(-\lambda_{2a\_2}t)] \cdot HEP_{-1} + [1 - \exp(-\lambda_{V4a\_3}t)] \cdot HEP_{-1} \} \cdot \{ [1 - \exp(-\lambda_{F1b\_1}t)] \cdot HEP_{-3} + [1 - \exp(-\lambda_{2b\_1}t)] \\
 & \cdot HEP_{-1} + [1 - \exp(-\lambda_{2b\_2}t)] \cdot HEP_{-1} + [1 - \exp(-\lambda_{2b\_3}t)] \cdot HEP_{-1} + [1 - \exp(-\lambda_{V4b\_3}t)] \cdot HEP_{-1} \} + \\
 & \{ [1 - \exp(-\lambda_{F1a\_3}t)] \cdot HEP_{-1} + [1 - \exp(-\lambda_{V4a\_1}t)] \cdot HEP_{-1} + [1 - \exp(-\lambda_{2a\_4}t)] \cdot HEP_{-1} \} \cdot \{ [1 - \exp(-\lambda_{V3a\_2}t)] \\
 & \cdot HEP_{-1} + [1 - \exp(-\lambda_{V5a\_3}t)] \cdot HEP_{-1} \} + \{ [1 - \exp(-\lambda_{F1b\_3}t)] \cdot HEP_{-1} + [1 - \exp(-\lambda_{V4b\_1}t)] \cdot HEP_{-1} + \\
 & [1 - \exp(-\lambda_{2b\_4}t)] \cdot HEP_{-1} \} \cdot \{ [1 - \exp(-\lambda_{V3b\_2}t)] \cdot HEP_{-1} + [1 - \exp(-\lambda_{V5b\_3}t)] \cdot HEP_{-1} \} + HEP_{4T3} + \\
 & [1 - \exp(-\lambda_{T3\_1}t)] \cdot HEP_{-1} + \{ [1 - \exp(-\lambda_{V11\_1}t)] + [1 - \exp(-\lambda_{V11\_2}t)] \} \cdot HEP_{-1} + \{ [1 - \exp(-\lambda_{V19\_1}t)] + \\
 & [1 - \exp(-\lambda_{V19\_2}t)] \} \cdot HEP_{-1} + \{ [1 - \exp(-\lambda_{F2a\_1}t)] \cdot HEP_{-3} + [1 - \exp(-\lambda_{3a\_1}t)] \cdot HEP_{-1} + [1 - \exp(-\lambda_{3a\_2}t)] \cdot \\
 & HEP_{-1} + [1 - \exp(-\lambda_{V9a\_3}t)] \cdot HEP_{-1} \} \cdot \{ [1 - \exp(-\lambda_{F2b\_1}t)] \cdot HEP_{-3} + [1 - \exp(-\lambda_{3b\_1}t)] \cdot HEP_{-1} + \\
 & [1 - \exp(-\lambda_{3b\_2}t)] \cdot HEP_{-1} + [1 - \exp(-\lambda_{3b\_3}t)] \cdot HEP_{-1} + [1 - \exp(-\lambda_{V9b\_3}t)] \cdot HEP_{-1} \} + \{ [1 - \exp(-\lambda_{F2a\_3}t)] \cdot \\
 & HEP_{-1} + [1 - \exp(-\lambda_{V9a\_1}t)] \cdot HEP_{-1} + [1 - \exp(-\lambda_{3a\_4}t)] \cdot HEP_{-1} \} \cdot \{ [1 - \exp(-\lambda_{V8a\_2}t)] \cdot HEP_{-1} + \\
 & [1 - \exp(-\lambda_{V10a\_3}t)] \cdot HEP_{-1} \} + \{ [1 - \exp(-\lambda_{F2b\_3}t)] \cdot HEP_{-1} + [1 - \exp(-\lambda_{V9b\_1}t)] \cdot HEP_{-1} + \\
 & [1 - \exp(-\lambda_{3b\_4}t)] \cdot HEP_{-1} \} \cdot \{ [1 - \exp(-\lambda_{V8b\_2}t)] \cdot HEP_{-1} + [1 - \exp(-\lambda_{V10b\_3}t)] \cdot HEP_{-1} \} + \\
 & \{ [1 - \exp(-\lambda_{F3a\_1}t)] \cdot HEP_{-3} + [1 - \exp(-\lambda_{4a\_1}t)] \cdot HEP_{-1} + [1 - \exp(-\lambda_{4a\_2}t)] \cdot HEP_{-1} + [1 - \exp(-\lambda_{V17a\_3}t)] \cdot \\
 & HEP_{-1} \} \cdot \{ [1 - \exp(-\lambda_{F3b\_1}t)] \cdot HEP_{-3} + [1 - \exp(-\lambda_{4b\_1}t)] \cdot HEP_{-1} + [1 - \exp(-\lambda_{4b\_2}t)] \cdot HEP_{-1} + \\
 & [1 - \exp(-\lambda_{4b\_3}t)] \cdot HEP_{-1} + [1 - \exp(-\lambda_{V17b\_3}t)] \cdot HEP_{-1} \} + \{ [1 - \exp(-\lambda_{F3a\_3}t)] \cdot HEP_{-1} + \\
 & [1 - \exp(-\lambda_{V17a\_1}t)] \cdot HEP_{-1} + [1 - \exp(-\lambda_{4a\_4}t)] \cdot HEP_{-1} \} \cdot \{ [1 - \exp(-\lambda_{V16a\_2}t)] \cdot HEP_{-1} + \\
 & [1 - \exp(-\lambda_{V18a\_3}t)] \cdot HEP_{-1} \} + \{ [1 - \exp(-\lambda_{F3b\_3}t)] \cdot HEP_{-1} + [1 - \exp(-\lambda_{V17b\_1}t)] \cdot HEP_{-1} + \\
 & [1 - \exp(-\lambda_{4b\_4}t)] \cdot HEP_{-1} \} \cdot \{ [1 - \exp(-\lambda_{V16b\_2}t)] \cdot HEP_{-1} + [1 - \exp(-\lambda_{V18b\_3}t)] \cdot HEP_{-1} \} + \\
 & \{ [1 - \exp(-\lambda_{V12\_1}t)] + [1 - \exp(-\lambda_{V13\_1}t)] + [1 - \exp(-\lambda_{5\_1}t)] + [1 - \exp(-\lambda_{5\_2}t)] \} \cdot HEP_{-1} + \{ [1 - \exp(-\lambda_{TV1\_1}t)] \\
 & + [1 - \exp(-\lambda_{TV1\_2}t)] \} \cdot HEP_{-1} + \{ [1 - \exp(-\lambda_{V14\_1}t)] + [1 - \exp(-\lambda_{V15\_1}t)] \} \cdot HEP_{-1} + \{ [1 - \exp(-\lambda_{6a\_1}t)] \cdot \\
 & HEP_{-2} + [1 - \exp(-\lambda_{6a\_2}t)] \cdot HEP_{-1} + [1 - \exp(-\lambda_{6a\_3}t)] \cdot HEP_{-1} \} \cdot \{ [1 - \exp(-\lambda_{6b\_1}t)] \cdot HEP_{-2} + \\
 & [1 - \exp(-\lambda_{6b\_2}t)] \cdot HEP_{-1} + [1 - \exp(-\lambda_{6b\_3}t)] \cdot HEP_{-1} + [1 - \exp(-\lambda_{V14\_2}t)] \cdot HEP_{-1} + [1 - \exp(-\lambda_{V15\_2}t)] \cdot \\
 & HEP_{-1} \} + [1 - \exp(-\lambda_{p1\_1}t)] \cdot HEP_{-1} \},
 \end{aligned} \tag{1}$$

Lubricating oil system reliability without redundancy can be expressed as follows:

$$\begin{aligned}
 R_s(t) = & 1 - \{ HEP_{4T1} + \{ [1 - \exp(-\lambda_{V2\_1}t)] + [1 - \exp(-\lambda_{T1\_1}t)] \} \cdot HEP_{-1} + HEP_{4T2} + \{ [1 - \exp(-\lambda_{V7\_1}t)] \\
 & + [1 - \exp(-\lambda_{T2\_1}t)] \} \cdot HEP_{-1} + [1 - \exp(-\lambda_{V6\_1}t)] \cdot HEP_{-1} + \{ [1 - \exp(-\lambda_{V3a\_1}t)] + [1 - \exp(-\lambda_{V5a\_1}t)] \} \cdot HEP_{-1} \\
 & + [1 - \exp(-\lambda_{F1a\_1}t)] \cdot HEP_{-3} + \{ [1 - \exp(-\lambda_{2a\_1}t)] + [1 - \exp(-\lambda_{2a\_2}t)] + [1 - \exp(-\lambda_{V4a\_3}t)] \} \cdot HEP_{-1} + \\
 & \{ [1 - \exp(-\lambda_{F1a\_3}t)] + [1 - \exp(-\lambda_{V4a\_1}t)] + [1 - \exp(-\lambda_{2a\_4}t)] \} \cdot HEP_{-1} + HEP_{4T3} + [1 - \exp(-\lambda_{T3\_1}t)] \cdot HEP_{-1} \\
 & + \{ [1 - \exp(-\lambda_{V11\_1}t)] + [1 - \exp(-\lambda_{V11\_2}t)] \} \cdot HEP_{-1} + \{ [1 - \exp(-\lambda_{V19\_1}t)] + [1 - \exp(-\lambda_{V19\_2}t)] \} \cdot HEP_{-1} \\
 & + [1 - \exp(-\lambda_{F2a\_1}t)] \cdot HEP_{-3} + \{ [1 - \exp(-\lambda_{3a\_1}t)] + [1 - \exp(-\lambda_{3a\_2}t)] + [1 - \exp(-\lambda_{V9a\_3}t)] \} \cdot HEP_{-1} + \\
 & \{ [1 - \exp(-\lambda_{F2a\_3}t)] + [1 - \exp(-\lambda_{V9a\_1}t)] + [1 - \exp(-\lambda_{3a\_4}t)] \} \cdot HEP_{-1} + [1 - \exp(-\lambda_{F3a\_1}t)] \cdot HEP_{-3} + \\
 & \{ [1 - \exp(-\lambda_{4a\_1}t)] + [1 - \exp(-\lambda_{4a\_2}t)] + [1 - \exp(-\lambda_{V17a\_3}t)] \} \cdot HEP_{-1} + \{ [1 - \exp(-\lambda_{F3a\_3}t)] + \\
 & [1 - \exp(-\lambda_{V17a\_1}t)] + [1 - \exp(-\lambda_{4a\_4}t)] \} \cdot HEP_{-1} + \{ [1 - \exp(-\lambda_{V12\_1}t)] + [1 - \exp(-\lambda_{V13\_1}t)] + [1 - \exp(-\lambda_{5\_1}t)] \\
 & + [1 - \exp(-\lambda_{5\_2}t)] \} \cdot HEP_{-1} + \{ [1 - \exp(-\lambda_{TV1\_1}t)] + [1 - \exp(-\lambda_{TV1\_2}t)] \} \cdot HEP_{-1} + \{ [1 - \exp(-\lambda_{V14\_1}t)] + \\
 & [1 - \exp(-\lambda_{V15\_1}t)] \} \cdot HEP_{-1} + \{ [1 - \exp(-\lambda_{6a\_1}t)] \cdot HEP_{-2} + [1 - \exp(-\lambda_{6a\_2}t)] \cdot HEP_{-1} + [1 - \exp(-\lambda_{6a\_3}t)] \cdot \\
 & HEP_{-1} \} + [1 - \exp(-\lambda_{p1\_1}t)] \cdot HEP_{-1} \},
 \end{aligned} \tag{2}$$

where:

t [h] - time,

$\lambda$  [ $h^{-1}$ ] - failure rates according to Tab.1.,

HEP - human error probabilities according to Tab. 2.

### 3. Results of the model investigations

Reliability values of lubricating oil system with and without redundancy of pumps and filters have been calculated in function of time and crew qualification levels. The results are shown on Fig. 2., Fig. 3., Fig. 4.

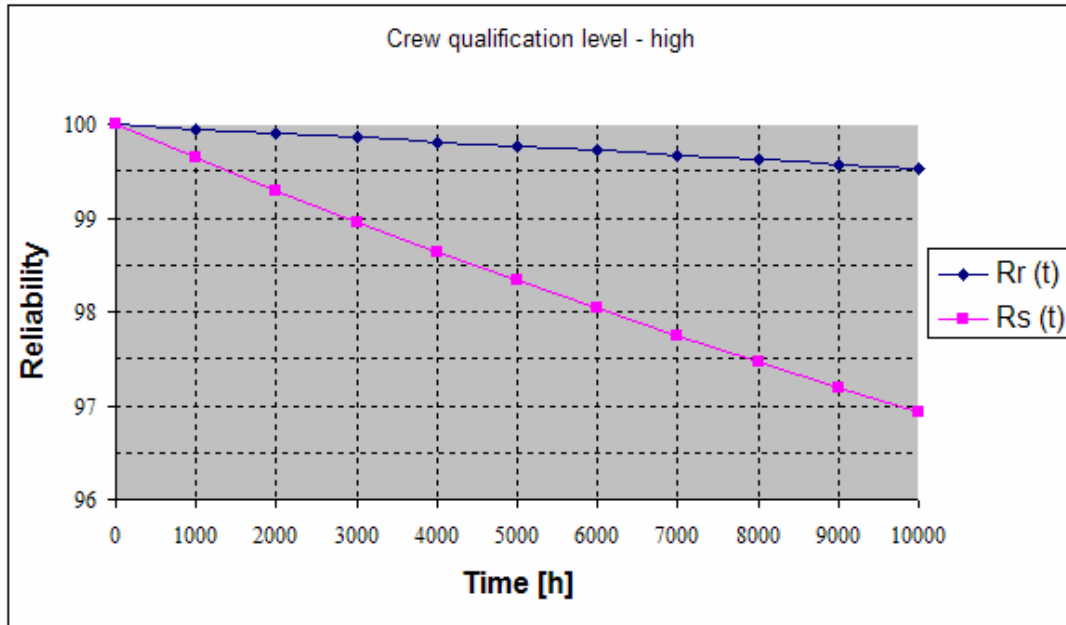

Fig. 2. Reliability function of lubricating oil system with redundancy  $R_r(t)$  and without redundancy  $R_s(t)$ , crew qualification level is high

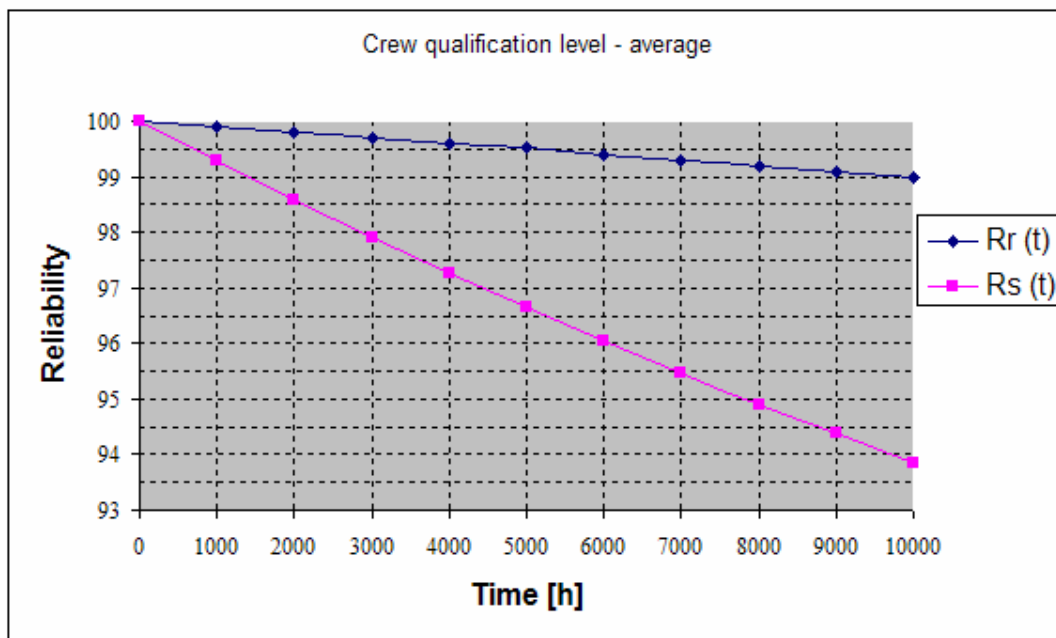

Fig. 3. Reliability function of lubricating oil system with redundancy  $R_r(t)$  and without redundancy  $R_s(t)$ , crew qualification level is average

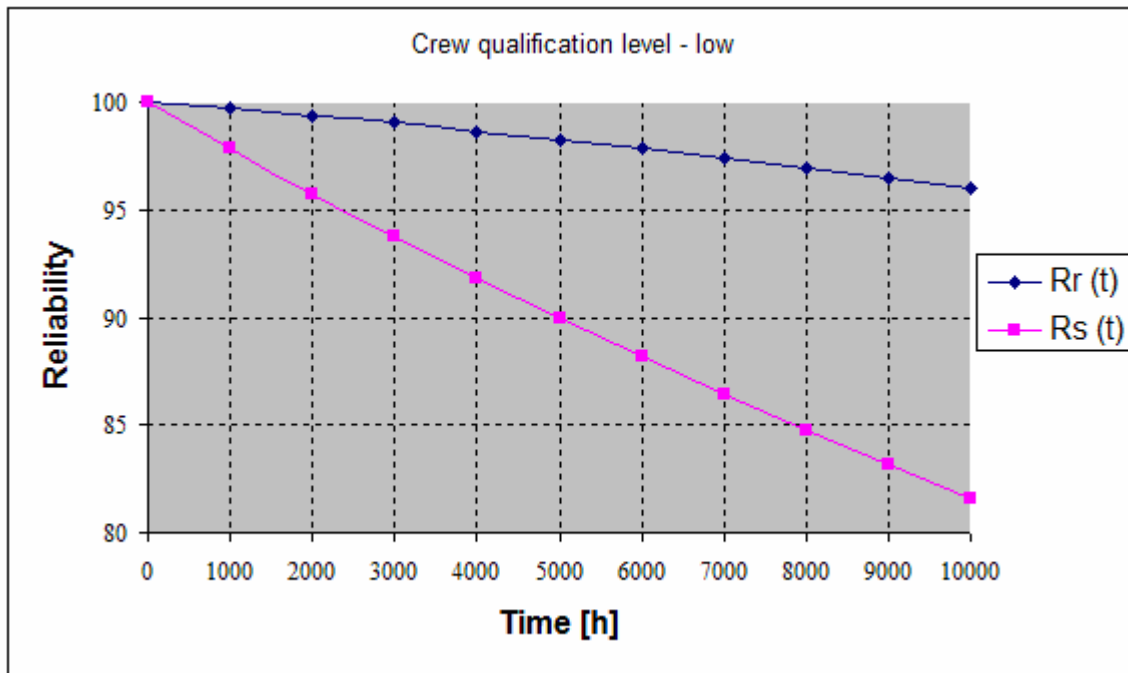

Fig. 4. Reliability function of lubricating oil system with redundancy  $R_r(t)$  and without redundancy  $R_s(t)$ , crew qualification level is low

#### 4. Conclusions derived from the model investigations

- ❑ Reliability of the lubricating oil system obviously depends on the reliability of relevant technical elements as well as on the crew qualification level – the reliability of human operator.
- ❑ The greater reliability of technical elements and human reliability the greater reliability of the system.
- ❑ Redundancy brings about the increase in the reliability of the lubricating oil system.
- ❑ The lower crew qualification level and lower reliability of technical elements the greater effect of redundancy to the reliability of the system.

Application of such models, like this one, is closely associated with data on reliability of technical elements used in shipbuilding. However they are unavailable in Poland. Perhaps they are saved in databases of classification societies like Det Norske Veritas or Lloyd Register. The other problem to solve is human error probabilities assessment. The first steps towards to deal with the problem have been already made by the author in [10].

#### References

- [1] Lloyd Register of Shipping, *Lloyd's Register Rules and Regulations - Rules and Regulations for the Classification of Ships, July 2005, incorporating Notice No. 1 - Main and Auxiliary Machinery - Machinery Piping Systems - Lubricating oil systems*, London 2005.
- [2] International Maritime Organization, *Guidelines for Formal Safety Assessment (FSA) for Use in the IMO Rule – Making Process*, MSC/Circ.1023 MEPC/Circ.392, London 2002.
- [3] MAN B&W Diesel A/S, *Engine Selection Guide, Two – stroke MC/MC-C Engines*, 6<sup>th</sup> Edition, January 2002.



- [4] OREDA, *Offshore Reliability Data*, 3<sup>rd</sup> Edition, DNV, Trondheim 1997.
- [5] Liberacki, R., Nowak, P., *Wyniki symulacji bezpieczeństwa napędowego statków serii B 488*, opracowanie wewnętrzne, Politechnika Gdańska, Gdańsk 1998.
- [6] Swain, A.D., NUREG/CR-4772, 1988.
- [7] Kosmowski, K.T., *Ocena niezawodności operatora w realizacji wybranych funkcji w procesie sterowania na przykładzie instalacji wytwarzania energii elektrycznej statków serii B 488*, Politechnika Gdańska, Gdańsk, 1997.
- [8] Radkowski, S., *Podstawy bezpiecznej techniki*, Politechnika Warszawska, Warszawa 2003.
- [9] Safety and Reliability Directorate UK Atomic Energy Authority, *Human Reliability Assessors Guide*, 1988.
- [10] Liberacki, R., *Modelowanie bezpieczeństwa środowiskowego statków*, rozprawa doktorska, Politechnika Gdańska, Gdańsk, 2005.