

ZBIGNIEW WALCZYK, Assoc.Prof.,D.Sc.
Gdańsk University of Technology and
The State Higher School
of Vocational Training, Elbląg

Influence of the steam within seals and glands of the turbine on its rotor motion stability

SUMMARY

In the paper assumptions for turbine seal modelling as well as the calculation results of the motion stability of a great-output turbo-set rotor are presented. The flow equation system was solved by using the linear perturbation method. On calculation of pressure distribution in the seal chambers it was possible to estimate values of the forces affecting the rotor in the seals.

Problems of turbo-set rotor dynamics were solved with the use of the transfer matrix method where influences of partial turbo-set systems (bearing oil film, foundation, turbine seals) were modeled by dynamic characteristics dependent on rotor rotational speed and vibration frequency. The theoretical results were partly confirmed by experimental investigations. The calculation results presented in the paper have been a part of the more thorough analysis of the great-output, energy-plant turbo-set [17,18].

INTRODUCTION

Unsatisfactory dynamic state of energy-plant turbo-sets can be explained by the phenomena occurring in the glands or turbine stage seals, which are frequently connected with the self-exciting vibrations. The steam turbine seals are one of many sources of significant influence on the rotor motion stability, apart from such as the slide rotor bearings, internal rotor damping or parametrical effects due to rotor stiffness asymmetry etc. The seal forces are not conservative and they depend on position and speed of the moving seal parts.

There are two kinds of seal forces. One of them is involved by pressure and friction of steam acting on the rotor parts in turbine labyrinth glands, or on a shrouding of rotor blade row. These forces are called „over-the-shrouding” forces. The second kind of the seal forces are circulation forces of blade row, which deal with the differences of the blade efficiency due to eccentricity of turbine stages (steam whirl – Thomas effect). The forces of high pressure glands and circulation forces of all turbo-set turbine cylinders should be taken into account.

The undesirable influence of turbine seal force can increase together with the increase of the turbo-set output which may reach the level of the so called „threshold output” (or „threshold capacity”) when the rotor motion stability is lost. Rotational speed of the rotor can have similar negative influence because an increase of the rotor speed can also lead to loss of the motion stability. It occurs at the rotor speed called the „limit rotor speed”.

It is very difficult to analyze the turbine seal forces because of the complex character of steam flow within seal chamber and through-out seal strips. Therefore the theoretical results should be verified experimentally.

The nature of the turbine labyrinth gland, over-the-shrouding and circulation forces and their approximate theoretical estimations were considered by many authors [1,2] [5,6] [7] [9] [10] [11,12,13] [19]. Some of them obtained contrary results. Especially the papers [5,6] are very important when the theoretical results are verified with the help of experimental investigations [4,8,16]. In many papers the problem of the seal force influence on the motion stability of the turbo-set rotor was discussed [7,12,13,17].

THEORETICAL MODEL OF THE SEALS

The purpose of further considerations is formulating an algorithm for calculation of the dynamic characteristics of the turbine seals. These characteristics are applied in the dynamic analysis method of the whole turbo-set [17,18] where the transfer matrix procedure is used in its part dealing with the rotors. In this paper the problem is limited to rotor transverse rotational vibrations. However it can be solved in a wider aspect by taking into account the coupled transverse-torsional-axial vibrations [18]. In the used transfer matrix method the following state vectors of the rotor cross-sections are applied :

$$\{w\} = \text{col}\{G, \Phi, M, T\} \quad (1)$$

where :

- G - complex rotor transverse deflection
- Φ - complex slope angle of rotor axis due to bending only (acc. to Timoshenko beam model)
- M - complex bending moment
- T - complex shearing force.

The transfer matrix is of the following general form :

$$D_k(\sigma) = D_k^r(\sigma) + D_k^*(\sigma) + D_k^{**}(\sigma) \quad (2)$$

where:

- $D_k^r(\sigma)$ - transfer matrix of the rotor element
- $D_k^*(\sigma)$ - transfer matrix of the seal forces of the turbine cylinder labyrinth glands and blade shrouding
- $D_k^{**}(\sigma)$ - transfer matrix of the blade row circulation forces
- k - index of rotor element
- $\sigma \in H$ - index of harmonic component
- H - set of harmonic components indices.

The main geometrical parameters of the seal are shown in Fig.1.

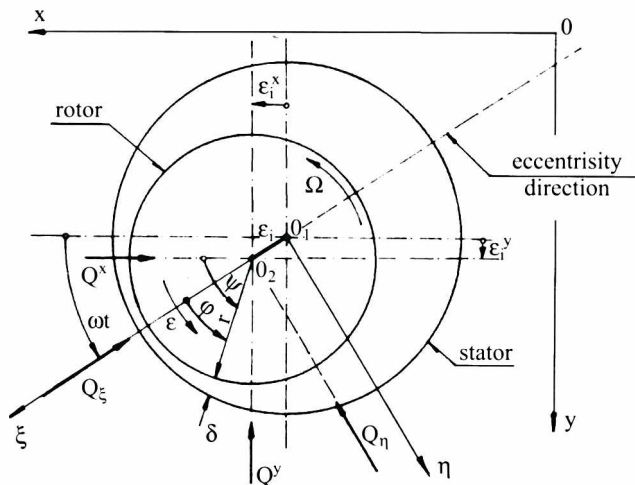

Fig.1. The cross-section of the seal with indicated main geometric parameters
 $Oxyz$ - global coordinate system $O_1\xi_1\eta_1$ - rotating system of coordinates
 O_1, O_2 - geometrical centre of gland stator and rotor part, respectively

Several assumptions are made to obtain the equations of continuity and circumferential momentum, as well as the equation of axial flow throughout the seal strips, with the applied contraction coefficient.

The assumptions are as follows :

- steam temperature is constant (case 1) or linearly changeable along the seal (case 2)
- the „wetted” seal chamber surfaces affect the steam stream by friction forces
- the steam is treated as the ideal gas
- the steam flow entering a chamber has the circumferential velocity being a part of that in the preceding seal chamber or that in space before the seal (before the first seal strip)
- the steam axial velocity in a seal chamber is neglected; it occurs only in a strip gap
- the movable seal part can perform translatory and angular motion (besides the basic rotational motion of the rotor).

The complex eccentricity of the seal strips can be expressed as follows (Fig.2b) :

$$\epsilon_i^c = \epsilon_i^x + j\epsilon_i^y + (1-l_i)(\vartheta_i^x + j\vartheta_i^y) = \epsilon_i^c + (1-l_i)\vartheta \quad (3)$$

for $i = 1, 2, \dots, (N_s - 1)$, and where (Fig.2b) :

- ϵ_1 - eccentricity of the first strip
- ϑ - slope angle of the seal
- N_s - number of the seal chambers
- $j = \sqrt{-1}$

The local size of the strip clearance is defined by :

$$\delta_i = \bar{\delta}_i - \epsilon_i \cos \varphi \quad (4)$$

where : $\bar{\delta}_i$ - mean (characteristic) strip clearance.

By taking into account the geometrical relationships of the seal (Fig.2.) the following formulas can be obtained :

$$\delta_i = \bar{\delta}_i - (P_i^x \cos \psi + P_i^y \sin \psi) \quad (5)$$

where :

$$P_i^x = \epsilon_i^x \sin \Sigma_i + [(1-l_i) \sin \Sigma_i + r_i \cos \Sigma_i] \vartheta^x \quad (6)$$

$$P_i^y = \epsilon_i^y \sin \Sigma_i + [(1-l_i) \sin \Sigma_i + r_i \cos \Sigma_i] \vartheta^y$$

Similar equations can be derived for the cross-section area of the seal chamber, f :

$$f_i = \bar{f}_i - F_i^x \cos \psi - F_i^y \sin \psi \quad (7)$$

where :

$$F_i^x = \frac{1}{2} \Xi_i b_i (\epsilon_i^x + \epsilon_{i+1}^x) \quad (8)$$

$$F_i^y = \frac{1}{2} \Xi_i b_i (\epsilon_i^y + \epsilon_{i+1}^y)$$

and :

Ξ - shape coefficient of the seal chamber cross-section .

The relative motion equations of the movable and stationary seal parts are as follows :

a)

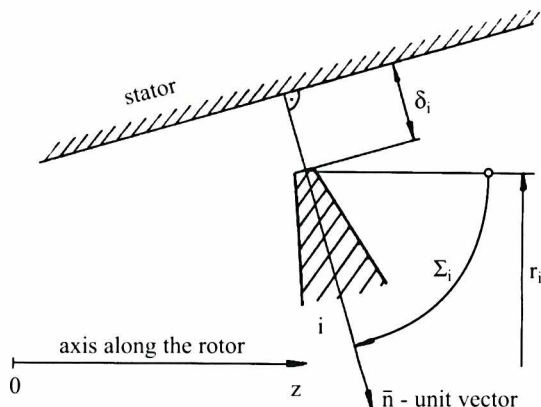

b)

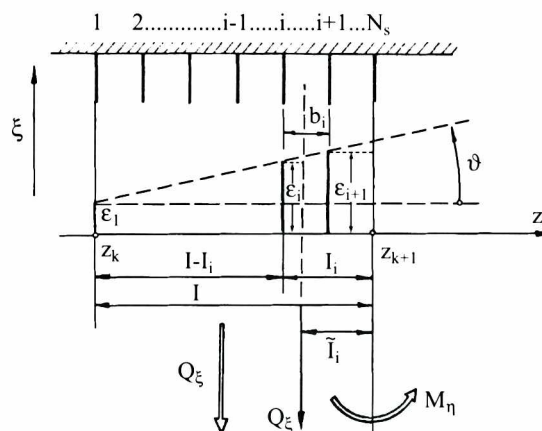

Fig.2. Axial cross-section of the seal in the plane of eccentricity:

a) geometrical parameters of the seal strip b) geometrical parameters of the seal chamber, and the seal forces.

$$\varepsilon_i^c = \sum_{\sigma \in H} \varepsilon_{i(\sigma)}^c e^{\Theta_{i(\sigma)} t} \quad (9)$$

$$\vartheta^c = \sum_{\sigma \in H} \vartheta_{i(\sigma)}^c e^{\Theta_{i(\sigma)} t}$$

where :

$\theta_{i(\sigma)} = \gamma + j\omega$ – eigenvalue in the case of free motion,

or

$\theta_{i(\sigma)} = j\Omega$ – rotor rotational speed in the case of forced motion.

By using the quantities shown in Fig.2b the following equations of the seal forces and moments can be obtained :

$$Q^x = \sum_{i=1}^{N_s-1} Q_i^x \quad Q^y = \sum_{i=1}^{N_s-1} Q_i^y \quad (10)$$

$$M^x = \sum_{i=1}^{N_s-1} \tilde{l}_i Q_i^y \quad M^y = - \sum_{i=1}^{N_s-1} \tilde{l}_i Q_i^x \quad (11)$$

where :

$$\tilde{l}_i = l_i - \frac{1}{2} b_i$$

The above defined forces originate from steam pressure in the chamber seal :

$$Q_i^x = \tilde{r}_i b_i \int_0^{2\pi} p_i \cos \psi \, d\psi$$

$$Q_i^y = \tilde{r}_i b_i \int_0^{2\pi} p_i \sin \psi \, d\psi \quad (12)$$

where :

p – pressure in the chamber
 $\tilde{r}_i = 0.5(r_i + r_{i+1})$ – mean radius of the seal chamber.

After application of the earlier described assumptions the basic equations of continuity and circumferential momentum, and the ideal gas state equation takes the following forms :

$$\frac{\partial}{\partial t} (f_i \rho_i)_i + \frac{\partial}{\partial s} (f_i \rho_i c_{u_i}) = w_i - w_{i+1} \quad (13)$$

$$\rho_i \frac{\partial}{\partial t} c_{u_i} + \rho_i c_{u_i} \frac{\partial}{\partial t} c_{u_i} + \frac{1}{f_i} w_{i+1} (c_{u_i} - c_{u_{i-1}}) =$$

$$= \frac{1}{f_i} \frac{\partial}{\partial s} (f_i p_i) + \left[\frac{\partial}{\partial s} T_i^{**} - \frac{\partial}{\partial s} T_i^* \right] \quad (14)$$

$$w_i^2 = \mu_i^2 \delta_i^2 (p_{i-1}^2 - p_i^2) \frac{1}{R T_i} \quad (15)$$

$$p_i = \rho_i R T_i \quad (16)$$

here :

c_u – circumferential component velocity
 w – steam discharge through seal gap, related to strip circumference unit length
 ρ – steam density

T – temperature
 R – gas constant
 μ – coefficient of discharge (contraction)
 T^*, T^{**} – friction forces exerted on wetted surfaces of the stationary and movable part of the seal chamber, respectively.

The quantities f, r, p, c_u are functions of the space variable s and time t .

DYNAMIC CHARACTERISTICS OF THE SEAL

The characteristics of the seal can be determined when the pressure distribution in the seal chambers is known. At first the auxiliary calculations should be performed. By integrating equation (13) the following relationship can be found :

$$\left(\bar{p}_i \right)^2 = \left(\bar{p}_{i-1} \right)^2 - \frac{W^2}{\left(2\pi r_i \bar{\delta}_i \mu_i \right)^2} \quad (17)$$

where the whole steam discharge through the seal is defined as :

$$W = \int_0^{2\pi} w_i r_i \, d\psi \quad (18)$$

Mean pressure values in the seal chambers can be calculated from (17) :

$$\left(\bar{p}_i \right)^2 = p_o^2 - \sum_{n=1}^i \frac{W^2}{\left(2\pi r_n \bar{\delta}_n \mu_n \right)^2} \quad (19)$$

Hence the whole seal discharge is the following :

$$W^2 = \frac{p_o^2 - p_{N_s}^2}{\sum_{i=1}^{N_s} \frac{1}{\left(2\pi r_i \bar{\delta}_i \mu_i \right)^2}} \quad (20)$$

where :

p_o, p_{N_s} – steam pressure before and behind the seal, respectively.

The basic equation system (13) ÷ (16) was solved by using the method of linear perturbation of the unknown quantities :

$$p_i = \bar{p}_i + \Delta p_i \quad \rho_i = \bar{\rho}_i + \Delta \rho_i$$

$$w_i = \bar{w}_i + \Delta w_i \quad c_{u_i} = \bar{c}_{u_i} + \Delta c_{u_i} \quad (21)$$

It is possible to transform the basic equation system to a new system of only two unknown functions :

- for pressure : $p_i(\psi, t)$, and
- for speed : $c_{u_i}(\psi, t)$.

On application of the perturbations (21) the new system of equations obtains the form :

$$\frac{\partial(\Delta c_{u_i})}{\partial \psi} + a_{1i} \frac{\partial(\Delta p_i)}{\partial t} + a_{2i} \frac{\partial(\Delta p_i)}{\partial \psi} =$$

$$= a_{3i} \Delta p_{i-1} + a_{4i} \Delta p_i + a_{5i} \Delta p_{i+1} +$$

$$+ a_{6i} \Delta \delta_{i+1} + a_{7i} \Delta \delta_i - a_{15i} \frac{\partial(\Delta f_i)}{\partial t} - a_{16i} \frac{\partial(\Delta f_i)}{\partial \psi} \quad (22)$$



$$\begin{aligned}
 a_{8i} \frac{\partial(\Delta c_{u_i})}{\partial t} + \frac{\partial(\Delta c_{u_i})}{\partial \psi} + a_{9i} \frac{\partial(\Delta p_i)}{\partial \psi} = \\
 = a_{10i} \Delta p_i + a_{11i} \Delta p_{i+1} + a_{12i} \Delta c_{u_i} + \\
 + a_{13i} \Delta c_{u_{i+1}} - a_{14i} \Delta \delta_{i+1} + a_{17i} \frac{\partial(\Delta f_i)}{\partial \psi}
 \end{aligned} \quad (23)$$

where :

$$\begin{aligned}
 a_{1i} &= \frac{\tilde{r}_i}{\bar{p}_i} & a_{2i} &= \frac{\bar{c}_{u_i}}{\bar{p}_i} & a_{3i} &= \frac{\tilde{r}_i}{\bar{f}_i \bar{p}_i} \omega_{1i} \\
 a_{4i} &= -\frac{\tilde{r}_i}{\bar{f}_i \bar{p}_i} (\omega_{2i} + \omega_{1i+1}) & a_{5i} &= \frac{\tilde{r}_i}{\bar{f}_i \bar{p}_i} \omega_{2i+1} \\
 a_{6i} &= \frac{\tilde{r}_i}{\bar{f}_i \bar{p}_i} \omega_{3i+1} & a_{7i} &= \frac{\tilde{r}_i}{\bar{f}_i \bar{p}_i} \omega_{3i} \\
 a_{8i} &= \frac{\tilde{r}_i}{\bar{c}_{u_i}} & a_{9i} &= \frac{1}{\bar{f}_i \bar{c}_{u_i}} \\
 a_{10i} &= \frac{\tilde{r}_i (\bar{c}_{u_i} - \bar{c}_{u_{i+1}})}{\bar{f}_i \bar{p}_i \bar{c}_{u_i}} \omega_{1i+1} \\
 a_{11i} &= \frac{-\tilde{r}_i (\bar{c}_{u_i} - \bar{c}_{u_{i+1}})}{\bar{f}_i \bar{p}_i \bar{c}_{u_i}} \omega_{2i+1}
 \end{aligned} \quad (24)$$

$$a_{12i} = \frac{1}{\bar{f}_i \bar{p}_i \bar{c}_{u_i}} (\tilde{r}_i \bar{w}_i - \Pi_i) \quad a_{13i} = \frac{-\tilde{r}_i \bar{w}_i}{\bar{f}_i \bar{p}_i \bar{c}_{u_i}}$$

$$a_{14i} = \frac{-\tilde{r}_i (\bar{c}_{u_i} - \bar{c}_{u_{i+1}})}{\bar{f}_i \bar{p}_i \bar{c}_{u_i}} \omega_{3i+1}$$

$$a_{15i} = \frac{\tilde{r}_i}{\bar{f}_i} \quad a_{16i} = \frac{\bar{c}_{u_i}}{\bar{f}_i} \quad a_{17i} = \frac{-\bar{p}_i}{\bar{f}_i \bar{p}_i \bar{c}_{u_i}}$$

In the above presented formulas the following quantities were applied :

$$\bar{w}_i = \frac{\bar{p}_{i-1}}{(\bar{p}_{i-1})^2 - (\bar{p}_i)^2} \quad \omega_{2i} = \bar{w}_i \frac{\bar{p}_i}{(\bar{p}_{i-1})^2 - (\bar{p}_i)^2}$$

$$\bar{\delta}_i \quad \Pi_i = \tilde{r}_i \bar{p}_i \left[\kappa_i^* B_i^* \bar{c}_{u_i} - \kappa_i^{**} B_i^{**} (u_i - \bar{c}_{u_i}) \right] \quad (25)$$

where :

- κ^*, κ^{**} - coefficients of the friction forces acting on the stationary and movable seal parts, respectively
- B^*, B^{**} - wetted perimeters of the stationary and movable seal parts, respectively
- u - circumferential velocity of the movable seal parts ($u_i = r_i \Omega$).

The excitation functions in (22) and (23) are the components of (5) and (7), {see also (9)}. They are time dependent.

$$\Delta \delta_i = -\left(P_i^x(t) \cos \psi + P_i^y(t) \sin \psi \right) \quad (26)$$

$$\Delta f_i = -\left(F_i^x(t) \cos \psi + F_i^y(t) \sin \psi \right)$$

The solution of the perturbation equations (22) and (23) can be expected in the following form :

$$\Delta p_i(\psi, t) = A_i(t) \sin \psi + B_i(t) \cos \psi \quad (27)$$

$$\Delta c_{u_i}(\psi, t) = C_i(t) \sin \psi + D_i(t) \cos \psi$$

where : A_i, B_i, C_i, D_i - another unknown time functions ($i = 1, 2, \dots, N_s$).

The mean value of the steam circumferential speed in the chamber depends on :

- the stator circumferential speed u_i - as the friction forces act on seal chamber surfaces
- the mean value of the steam circumferential speed in the preceding seal chambers

$$\bar{c}_{u_i} = \beta_i u_i + \eta_i \bar{c}_{u_{i-1}} \quad (28)$$

where :

β_i, η_i - appropriately matched coefficients (to tune the model).

By substituting (27) into (22) and (23) the equation system of the following matrix form can be obtained :

$$\bar{N}_1 \dot{\mathbf{v}} + \bar{N}_2 \mathbf{v} + \bar{N}_3 \mathbf{v} = \mathbf{u} \quad (29)$$

where :

$$\mathbf{v} = \mathbf{A} + \mathbf{j} \mathbf{B} \quad (30)$$

and

$$\mathbf{A} = \text{col} \{A_1, A_2, \dots, A_{N_s+1}\} \quad (31)$$

$$\mathbf{B} = \text{col} \{B_1, B_2, \dots, B_{N_s+1}\}$$

The quantity u which appears on the right side of (29) is the kinematic excitation of the steam in the seal chamber, being a linear combination of the quantities (9). The solution of (29) can be expected in the following form :

$$\mathbf{v} = \sum_{\sigma \in H} \mathbf{v}(\sigma) e^{\Theta(\sigma)t} \quad (32)$$



After substitution of (32) into (29) the following harmonic components of the unknown quantities can be found :

$$v(\sigma) = K_{1(\sigma)} \varepsilon_{1(\sigma)}^x + K_{2(\sigma)} \Phi_{1(\sigma)}^* \quad \text{and} \quad (33)$$

$$v(\sigma) = B(\sigma) + j \Lambda(\sigma) \quad \Phi_{1(\sigma)}^* = j \vartheta$$

The real form of the above shown equation is as follows :

$$B(\sigma) = K_{1(\sigma)}^x \varepsilon_{1(\sigma)}^x - K_{1(\sigma)}^y \varepsilon_{1(\sigma)}^y + K_{2(\sigma)}^x \Phi_{1(\sigma)}^{*x} - K_{2(\sigma)}^y \Phi_{1(\sigma)}^{*y} \quad (34)$$

$$\Lambda(\sigma) = K_{1(\sigma)}^y \varepsilon_{1(\sigma)}^x + K_{1(\sigma)}^x \varepsilon_{1(\sigma)}^y + K_{2(\sigma)}^y \Phi_{1(\sigma)}^{*x} + K_{2(\sigma)}^x \Phi_{1(\sigma)}^{*y}$$

where :

K - matrix of coefficients obtained by means of the conformal transformations of the solved equation system.

By substituting (21) into (12) the new expressions of the seal forces are obtained :

$$Q_i^x = \tilde{r}_i b_i \int_0^{2\pi} \Delta p_i \cos \psi \, d\psi$$

$$Q_i^y = \tilde{r}_i b_i \int_0^{2\pi} \Delta p_i \sin \psi \, d\psi \quad (35)$$

By using the obtained solutions (34) the above given formulas can be expressed as follows :

$$Q(\sigma)^x = \pi \sum_{i=1}^{N_g-1} \tilde{r}_i b_i B_{i(\sigma)} \quad Q(\sigma)^y = \pi \sum_{i=1}^{N_g-1} \tilde{r}_i b_i A_{i(\sigma)} \quad (36)$$

$$M(\sigma)^x = \pi \sum_{i=1}^{N_g-1} \tilde{r}_i b_i \tilde{l}_i A_{i(\sigma)} \quad M(\sigma)^y = -\pi \sum_{i=1}^{N_g-1} \tilde{r}_i b_i \tilde{l}_i B_{i(\sigma)}$$

for each harmonic component ($\sigma \in H$) separately.

The summation in the above given expressions can be replaced by the appropriate diagonal matrices :

$$R = \pi \operatorname{diag} [\tilde{r}_1 b_1, \dots, \tilde{r}_1 b_1, \dots, \tilde{r}_{N_g-1} b_{N_g-1}]$$

$$T = \pi \operatorname{diag} [\tilde{r}_1 b_1 \tilde{l}_1, \dots, \tilde{r}_1 b_1 \tilde{l}_1, \dots, \tilde{r}_{N_g-1} b_{N_g-1} \tilde{l}_{N_g-1}] \quad (37)$$

$$J = \operatorname{col} \{1, 1, \dots, 1\}$$

The forces (36) can be expressed in the following forms :

$$Q(\sigma)^x = J R B(\sigma) \quad Q(\sigma)^y = J R A(\sigma)$$

$$M(\sigma)^x = J T A(\sigma) \quad M(\sigma)^y = -J T B(\sigma) \quad (38)$$

The dynamic characteristics of the seal are as follows :

$$S_{(\sigma)}^{xx} = S_{(\sigma)}^{yy} = J R K_{1(\sigma)}^x \quad S_{(\sigma)}^{x\varphi^x} = -S_{(\sigma)}^{y\varphi^y} = -J R K_{2(\sigma)}^x$$

$$S_{(\sigma)}^{xy} = -S_{(\sigma)}^{yx} = -J R K_{1(\sigma)}^y \quad S_{(\sigma)}^{\varphi^x x} = S_{(\sigma)}^{\varphi^y y} = J T K_{1(\sigma)}^y \quad (39)$$

$$S_{(\sigma)}^{\varphi^x \varphi^x} = S_{(\sigma)}^{\varphi^y \varphi^y} = -J T K_{2(\sigma)}^y \quad S_{(\sigma)}^{x\varphi^y} = -S_{(\sigma)}^{y\varphi^x} = J R K_{2(\sigma)}^y$$

$$S_{(\sigma)}^{\varphi^x \varphi^y} = -S_{(\sigma)}^{\varphi^y \varphi^x} = -J T K_{2(\sigma)}^x \quad S_{(\sigma)}^{\varphi^y x} = -S_{(\sigma)}^{\varphi^x y} = J T K_{1(\sigma)}^x$$

With the use of the above shown characteristics the seal forces can be determined by the formulas :

$$Q^x = S^{xx} \varepsilon_1^x + S^{xy} \varepsilon_1^y + S^{x\varphi^x} \Phi^{*x} + S^{x\varphi^y} \Phi^{*y}$$

$$Q^y = S^{yx} \varepsilon_1^x + S^{yy} \varepsilon_1^y + S^{y\varphi^x} \Phi^{*x} + S^{y\varphi^y} \Phi^{*y} \quad (40)$$

$$M^x = S^{\varphi^x x} \varepsilon_1^x + S^{\varphi^x y} \varepsilon_1^y + S^{\varphi^x \varphi^x} \Phi^{*x} + S^{\varphi^x \varphi^y} \Phi^{*y}$$

$$M^y = S^{\varphi^y x} \varepsilon_1^x + S^{\varphi^y y} \varepsilon_1^y + S^{\varphi^y \varphi^x} \Phi^{*x} + S^{\varphi^y \varphi^y} \Phi^{*y}$$

The presented method makes it possible to obtain the characteristics of the „over-the-shrouding” seal forces and the forces of the turbine cylinder labyrinth glands.

MATRICES OF THE FORCES OF TURBINE BLADE ROW AND OF TURBINE CYLINDER LABYRINTH GLANDS

The transfer matrices of the seal forces of the turbine cylinder labyrinth glands and the „over-the-shrouding” forces of the blade row, applied in (2) are of a block structure :

$$D_{k(\sigma)}^* = \begin{bmatrix} 0 & 0 \\ d_{k(\sigma)}^* & 0 \end{bmatrix} \quad \text{where} \quad d_{k(\sigma)}^* = \begin{bmatrix} D_1 & D_2 \\ D_3 & D_4 \end{bmatrix}_{k(\sigma)} \quad (41)$$

The elements of above described matrix can be defined with the help of formulas (40) for each harmonic component ($\sigma \in H$) separately.

$$D_{1(\sigma)} = S_{(\sigma)}^{\varphi^x x} - j S_{(\sigma)}^{\varphi^x y} \quad D_{2(\sigma)} = S_{(\sigma)}^{\varphi^x \varphi^x} - j S_{(\sigma)}^{\varphi^x \varphi^y} \quad (42)$$

$$D_{3(\sigma)} = S_{(\sigma)}^{xx} - j S_{(\sigma)}^{xy} \quad D_{4(\sigma)} = S_{(\sigma)}^{x\varphi^x} - j S_{(\sigma)}^{y\varphi^x}$$

The transfer matrix of the blade row circulation forces, applied in (2), is also of the block structure :

$$D_{k(\sigma)}^{**} = \begin{bmatrix} 0 & 0 \\ d_{k(\sigma)}^{**} & 0 \end{bmatrix} \quad \text{where} \quad d_{k(\sigma)}^{**} = \begin{bmatrix} \hat{D}_1 & \hat{D}_2 \\ \hat{D}_3 & \hat{D}_4 \end{bmatrix} \quad (43)$$

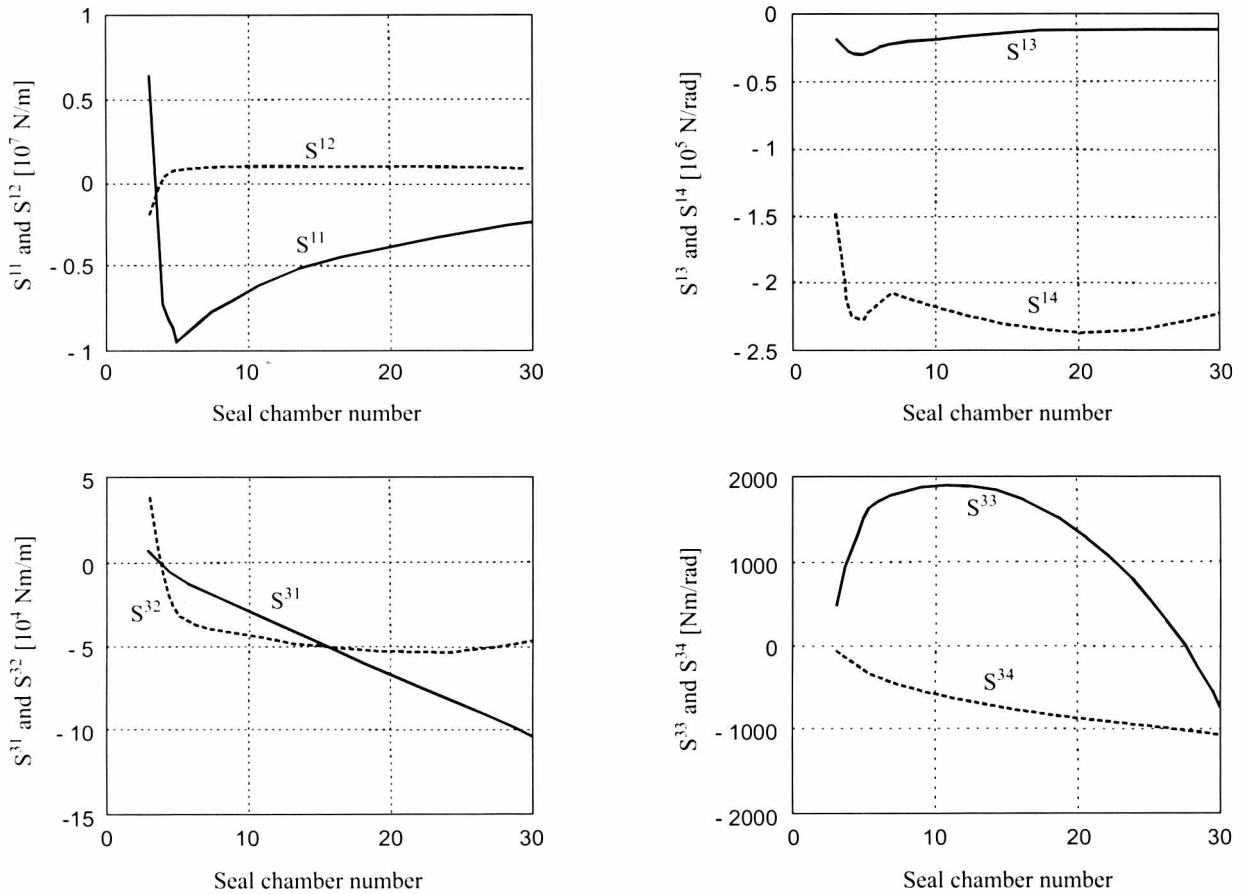

Fig.5. The dynamic characteristics of the seal calculated for the example No.1

Notation :

S^{11} [N/m] – the basic translatory characteristics (rigidity) S^{12} [N/m] – the coupling translatory characteristics
 S^{13}, S^{14} [N/rad] – the coupling translatory-rotary characteristics
 S^{31}, S^{32} [Nm/m] – the coupling rotary-translatory characteristics
 S^{33} [Nm/rad] – the basic rotary characteristics (rigidity) S^{34} [Nm/rad] – the coupling rotary characteristics.

The calculation results are presented in Fig.5.

In Fig.5 it can be observed that some characteristics change their signs which can lead to decreasing the rotor motion stability limit.

Example No 2

The elements of the matrices of the blade row circulation forces (2) of 200 MW energy-plant turbo-set were calculated and then used in the analysis of the turbo-set rotor motion stability. The rotor slide bearings and turbo-set foundation were also taken into account.

Calculated values of the circulation force dynamic characteristics are shown in Tab.1. The free vibration eigenvalues resulting from the rotor motion stability analysis are given in Tab.2 for two calculation variants.

Stability of the motion harmonic component is lost when the real part of the relevant eigenvalue is positive. In the case of **VARIANT 1**, i.e. when all turbo-set turbines are taken into consideration and the foundation damping is neglected, the 2nd motion harmonic component loses the stability ($\text{Re}(\lambda) = \gamma = 1.63$, Tab.2). More detailed investigations, in which the turbines are separately considered, show that the MP turbine ($\text{Re}(\lambda) = \gamma = 1.40$, Tab.2) is responsible for this motion stability loss. But in the case of **VARIANT 2**, i.e. when the foundation damping is taken into account the turbo-set rotor motion stability is theoretically ensured. The motion stability limit decreases when the turbo-set capacity (output) increases. In **VARIANT 1** the threshold capacity is below the operating power output of 200 MW.

Tab.1. The circulation force dynamic characteristics of 200 MW turbo-set {elements of matrix (43)}

| No of stage | HP turbine | | | | No of stage | MP turbine | | | | No of stage | LP turbine | | | |
|-------------|-------------|-------------|-------------|-------------|-------------|-------------|-------------|-------------|-------------|-------------|-------------|-------------|-------------|-------------|
| | \hat{D}_1 | \hat{D}_2 | \hat{D}_3 | \hat{D}_4 | | \hat{D}_1 | \hat{D}_2 | \hat{D}_3 | \hat{D}_4 | | \hat{D}_1 | \hat{D}_2 | \hat{D}_3 | \hat{D}_4 |
| | kN | Nm | kN/m | kN | | kN | Nm | kN/m | kN | | kN | Nm | kN/m | kN |
| 11 | 0 | 6921.1 | 0 | 247.2 | 1 | 0 | -4121.8 | 0 | -1957.9 | 4L | 0 | -0.23 | 0 | -508.6 |
| 10 | 0 | 5793.0 | 0 | 269.4 | 2 | 0 | -4089.2 | 0 | -1635.7 | 3L | 0 | -0.12 | 0 | -326.7 |
| 9 | 0 | 5114.5 | 0 | 284.1 | 3 | 0 | -3591.4 | 0 | -1257.0 | 2L | 0 | -0.75 | 0 | -1120.3 |
| 8 | 0 | 5370.4 | 0 | 298.4 | 4 | 0 | -2372.5 | 0 | -771.1 | 1L | 0 | -1.34 | 0 | -1805.8 |
| 7 | 0 | 5414.6 | 0 | 300.8 | 5 | 0 | -2173.9 | 0 | -706.5 | 1R | 0 | -1.34 | 0 | -1805.8 |
| 6 | 0 | 5784.1 | 0 | 321.3 | 6 | 0 | -1832.3 | 0 | -641.3 | 2R | 0 | -0.75 | 0 | -1120.3 |
| 5 | 0 | 5939.8 | 0 | 330.0 | 7 | 0 | -2176.1 | 0 | -761.6 | 3R | 0 | -0.12 | 0 | -326.7 |
| 4 | 0 | 5950.7 | 0 | 331.1 | 8 | 0 | -1801.5 | 0 | -1684.4 | 4R | 0 | -0.23 | 0 | -508.6 |
| 3 | 0 | 6310.3 | 0 | 350.6 | 9 | 0 | -1541.6 | 0 | -1580.1 | | | | | |
| 2 | 0 | 6526.2 | 0 | 362.6 | 10 | -19.0 | 0 | -2482.4 | 0 | | | | | |
| 1 | 0 | 6835.1 | 0 | 379.7 | 11 | -17.3 | 0 | -2610.7 | 0 | | | | | |

L – left R – right

Tab.2. Influence of the blade row circulation forces on the free vibration eigenvalues ($\lambda = \gamma + j\omega$) at 3000 rpm for different output levels :
Variant 1 – without damping in the turbo-set foundation **Variant 2** – with damping in the turbo-set foundation

| Variant | | 1 | | | | | | | | | | | | 2 | | | | | |
|--------------------|----|----------|----------|----------|----------|----------|----------|----------|----------|----------|----------|----------|----------|----------|----------|----------|----------|-------|-------|
| Output | MW | 0 | | 100 | | 200 | | | | | | 0 | | 100 | | 200 | | | |
| turbines | | HP | | HP | | HP | | MP | | MP | | LP | | HP | | HP | | | |
| | | MP | | MP | | MP | | MP | | LP | | MP | | LP | | | | | |
| Harmonic component | | γ | ω | γ | ω | γ | ω | γ | ω | γ | ω | γ | ω | γ | ω | γ | ω | | |
| | | 1/s | rad/s | 1/s | rad/s | 1/s | rad/s | 1/s | rad/s | 1/s | rad/s | 1/s | rad/s | 1/s | rad/s | 1/s | rad/s | | |
| 1 | | -3.33 | 124.6 | -1.38 | 127.6 | -0.58 | 130.6 | -3.40 | 124.6 | -0.43 | 130.6 | -3.33 | 124.6 | -5.10 | 131.5 | -3.39 | 113.0 | -3.22 | 113.3 |
| 2 | | -6.81 | 147.8 | -3.32 | 149.9 | 1.63 | 151.3 | -6.75 | 147.8 | 1.40 | 151.3 | -6.79 | 147.9 | -8.22 | 151.2 | -5.28 | 153.4 | -1.29 | 155.5 |
| 3 | | -15.04 | 154.9 | -16.05 | 154.8 | -16.58 | 155.2 | | | | | | | | | | | | |
| 4 | | -20.18 | 196.2 | -20.18 | 196.2 | -20.16 | 196.2 | | | | | | | | | | | | |
| 5 | | -20.37 | 190.8 | -23.24 | 190.4 | -25.91 | 191.2 | | | | | | | | | | | | |
| 6 | | -25.88 | 231.1 | -25.88 | 231.2 | -25.89 | 231.2 | | | | | | | | | | | | |
| 7 | | -42.68 | 197.4 | -44.68 | 195.4 | -47.52 | 193.1 | | | | | | | | | | | | |
| 8 | | -63.17 | 279.7 | -62.54 | 279.9 | -62.01 | 279.9 | | | | | | | | | | | | |
| 9 | | -52.48 | 384.8 | -52.44 | 384.8 | -52.40 | 384.8 | | | | | | | | | | | | |
| 10 | | -65.89 | 421.0 | -65.91 | 421.1 | -65.94 | 421.1 | | | | | | | | | | | | |

CONCLUSIONS

- In the paper the method was presented for calculating the dynamic characteristics of the seal forces of the turbine cylinder labyrinth glands as well as the „over-the-shrouding” and blade row circulation forces. Application of the method was exemplified by some calculations performed with the use of a specially elaborated computer program .
- In many cases the analysis of the turbo-set rotor dynamic properties showed that only if all machine subsystems and all non-conservative forces (including fluid-structure interaction forces) are taken into consideration the problem of rotor motion stability can be solved with good agreement between results of the experimental and theoretical investigations.
 Therefore it can be concluded that :
 - ♦ in the considered problems significant correlation appears between the turbo-set output and rotor motion stability due to phenomena occurring within the turbine seals
 - ♦ the phenomena occurring in several first gland chambers (where steam pressure is relatively high) have the most important influence on rotor motion stability
 - ♦ the moment of momentum of the steam flow before the first seal chamber and „carry-over” effect inside the gland has distinct influence on the seal dynamic characteristics
 - ♦ rotor motion stability can be lost not only at the first (lowest) vibration form as the external and internal damping in the partial turbo-set systems (rotor, foundation, bearing oil film forces) have great influence on this stability.

aised by Jan Kiciński, Prof.,D.Sc.

ENCLATURE

- ...a₁₇ - auxiliary coefficients
- width of steam chamber cross-section
- wetted perimeters of the seal
- tangential (circumferential) velocity of steam in seal chamber
- transfer matrix
- cross-section area of seal chamber
- auxiliary parameter of seal chamber geometry dealing with transverse cross-section change of the seal channel
- rotor deflection
- set of harmonic components indices

- $j = \sqrt{-1}$
- k - index of rotor element
- l - length
- L - seal axial length
- M - moment of steam force in the seal
- \mathcal{M} - complex bending moment
- N_s - number of seal strips
- p - steam pressure
- P - auxiliary parameter of seal chamber geometry dealing with change of seal clearance value
- Q - steam force in the seal
- r - radius of seal slot (clearance) location
- R - gas constant
- s = r · φ - space variable index
- S - seal dynamic characteristics
- t - time
- T - steam temperature
- \mathcal{T} - complex shearing force
- u - tangential velocity of rotor side surface
- w - unitary intensity of steam flow in the seal
- {w} - state vector of rotor cross-section
- W - steam flow intensity in the seal
- A, B, N₁, N₂, N₃, K, R, T, J, v, u - auxiliary matrices
- β - seal model „tuning” coefficient dealing with circumferential flow velocity of medium into the seal
- γ - damping parameter [γ = Re(θ)]
- δ - seal chamber height
- ε - rotor displacement in the seal
- ε^c - complex displacement (eccentricity)
- θ - slope angle of seal axis
- η - seal model „tuning” coefficient dealing with exchange of medium momentum between seal chambers („carry-over effect”)
- θ - complex eigenvalue
- κ*, κ** - coefficients of steam friction forces in the seal
- μ - contraction coefficient
- ρ - steam density
- σ - index of harmonic component
- Σ - angular position of seal strip
- ψ, φ - angular coordinates
- Φ - complex slope angle of rotor axis
- Φ* - total complex slope angle of rotor axis
- ω - free vibration frequency [ω = Im(θ)]
- ω₁, ω₂, ω₃, Π - auxiliary coefficients
- Ω - rotor rotational speed

Upper indices

- (\sim) - mean value
- ($\hat{\cdot}$) - value at the rotor centre position

1. Alford J.S.: *Protection of labyrinth seals from flexural vibration*. J. of Eng. for Power. April 1964
2. Alford J.S.: *Protecting turbo machinery from self-excited rotor whirl*. J. of Eng. for Power. October 1965
3. Graf M.B., Wong T.S., Greitzer E.M., Marble F.E., Tan C.S., Shin H., Wisler D.: *Effects of Nonaxisymmetric Tip Clearance on Axial Compressor Performance and Stability*. J. of Turbomach. V.120, October 1998
4. Kosowski K., Piwowarski M.: *The experimental rig for investigations of aerodynamic forces causing self-exciting vibration in turbo machinery systems*. Second Int. Scien. Technic. Conf.: Explo-Diesel and Gas Turbine'01. Gdańsk-Międzdroje-Copenhagen. 2001
5. Kostyuk A.G.: *Circulation forces over the shrouding and their influence on the threshold capacity of large turbine units*. (in Russian). Teploenergetika, 1975, No 3
6. Kostyuk A.G.: *Analysis of the unsteady flow in turbine labyrinth seals*. (in Russian). Teploenergetika, 1986, No 12
7. Krämer E.: *Selbsterregte Schwingungen von Wellen infolge von Querkraften*. Brennst. Wärme Kraft, 1968, No 7, Vol. 20
8. Kurahashi M., Inoue Y., Abe T., Fujikawa T.: *Spring and damping coefficients of the labyrinth seals*. Intern. Conf. on Vibration in Rot. Mach. Cambridge, 1980
9. Lomakin A.A.: *The calculation of the rotor critical speed and protective conditions of the dynamical rotor stability of the hydraulic turbine considering the labyrinth seal forces*. (in Russian). Energomashinostr. 1958, No 4
10. Piltz E.: *Belastungen von Dampfturbinenlaufrädern bei Auslenkungen der Welle*. Konstruktion, 1972, No 24
11. Piltz E.: *Einfluss von Dampfbelastungen auf die Stabilitätsgrenze einer einstufigen Modellturbine*. Konstruktion, 1973, No 25
12. Pollman E., Termuehlen H.: *Turbine rotor vibrations excited by steam forces (steam whirl)*. Paper nr 75-WA/Pwk-11. ASME, 1975
13. Pollman E., Schwerdtfeger H., Termuehlen H.: *Flow excited vibrations in high-pressure turbines (steam whirl)*. J. of Eng. for Power. April 1978
14. Thomas H.J.: *Unstable oscillations of turbine rotors due to steam leakage in the clearances of the sealing glands and the buckets*. Bull. de l'AIM 71. 1958, No 11/12
15. Thomas H.J.: *Grenzleistungsprobleme bei thermischen Turbomaschinen*. Mitt. VGB 51. 1981, No 4
16. Thomas H.J.: *Zur Laufstabilität einfacher Turborotoren, besonders bei Spalrerregung*. Konstruktion, 1978, No 30
17. Walczyk Z.: *Dynamics of the energy-plant rotating machines*. (in Polish). Mechanics LXIV. Technical University of Gdańsk. Gdańsk, 1992
18. Walczyk Z.: *Dynamics of the energy-plant turbo-sets. Fundamental and coupling vibrations*. (in Polish). Technical University of Gdańsk. 2001
19. Wohlrab R.: *Einfluss der Lagerung auf die Laufstabilität einfacher Rotoren mit Spalrerregung*. Konstruktion, 1976, No 28

Miscellanea

Cooperation of museology experts

In the end of February this year the Central Maritime Museum in Gdańsk hosted two international meetings of museology experts. The first of them was devoted to protection of common heritage of Baltic countries. Cooperation in cataloguing historical wrecks and similar antique objects was discussed. Such activity has been already carried out in Germany, Sweden and Poland. The difficulties met in that area are a.o.: location of underwater archeological sites and their protection, as well as acceptance of common qualifying criteria of the finds from the point of view of their historical value. In different countries opinions on the problem are not the same.

The second meeting in which apart from Poles also Spaniards, Germans and Portuguese took part was a conference of the group of experts in museum management, which has realized the EU project on elaboration of an Internet data base of European maritime museums, or - in other words - international virtual display of exhibits from maritime museums in Gdańsk, Bilbao, Bremerhaven and Lisbon. The German Shipping Museum coordinates this project.



Jubilee scientific conference JURATA 2001

For Polish shipbuilding industry the year 2001 was 55th of ship designing and 50th of R&D activity, as well as 30th anniversary of establishment of the Ship Design and Research Centre (CTO), Gdańsk. On this occasion CTO supported by the marine technology faculties of technical universities in Gdańsk and Szczecin, Polish Register of Shipping, as well as Gdańsk Shipyard, Gdynia Shipyard, Northern Shipyard in Gdańsk, Polish Navy and the Gdańsk Shiprepair Yard Remontowa, organized the jubilee scientific conference titled :

JURATA 2001

which - with participation of 130 Polish shipbuilding specialists - was held on 22-23 September 2001 at Jurata on Hel Peninsula. 55 papers prepared for the conference were assigned to 6 topical groups :

- Hydromechanics
- Structural mechanics
- Designing
- Engineering processes
- Equipment
- Research and Education.

14 papers on **hydromechanics** dealt a.o. with : modelling of flow around ship body and propeller, ship manoeuvrability qualities, modelling of ship motions and loads in waves, problems of ship model testing and launching in difficult conditions.

6 papers were devoted to **structural mechanics**, which dealt a.o. with : fatigue life of structural elements, damages to ship hulls and strength assessment of their structures, structural vibration analyses during the entire ship production process as well as structural safety of liquid-filled tanks.

8 papers dealt with **designing**. Their authors attracted participants' attention a.o. to changes and development trends in ship design process and importance of scientific research for the process, application of simulation techniques and role of certification for designing, as well as to some aspects of floating dock design, and a CAD software for ship automation systems.

In the area of **engineering processes** 12 papers were presented dealing with such problems as : accuracy of technological operations, application of novel materials in shipbuilding, analyses of steel grades and optimization of cathodic protection means, testing of structural materials, pipe routing optimization, application of sandwich panels to ship structures and organization of their manufacturing and quality assurance.

7 papers devoted to ship **equipment**, were focussed on problems of application of a cycloidal rudder (VCR) and hydrostatic drives, investigations of ship propulsion operation and measurements of shipborne noise, installation of computer systems on-board ships, new generation of shipboard winches as well as designing of deck cranes.

In 8 papers concerning problems of **research and personnel education** for shipbuilding Faculty of Ocean Engineering and Ship Technology, Gdańsk University of Technology, Ship Design and Research Centre of Gdańsk and Polish Register of Shipping, presented their achievements obtained so far as well as current activities in that area.