

Interference in Power system for traction drive with PMSM

Abstract. The paper deals with the significant results of the research of the current harmonic spectrum in traction drive with permanent magnet synchronous motors (PMSM). The research was done in the experimental workplace with a real traction drive for wheel vehicles. The spectrums were analyzed by the specialized device on the basis of a central measuring station. The knowledge of marked subharmonic components of stator winding currents is the most significant finding of this research. The frequencies of these components are given by frequency multiples of mechanical speeds. The subharmonic components also pass to DC current at the traction inverter input site. This fact is particularly important from the viewpoint of legislative requirements to electromagnetic compatibility (EMC) of drive with railway interlocking devices.

Streszczenie. W artykule przedstawiono główne wyniki badań widma częstotliwościowego prądu obciążenia trakcyjnego układu napędowego z silnikami PMSM przeprowadzonych na stanowisku eksperymentalnym wyposażonym w trakcyjny silnik pojazdu szynowego. Najbardziej istotnym wynikiem pomiarów jest znajomość kluczowych harmoniczných prądu obciążenia, których częstotliwość jest równa wielokrotności prędkości obrotowej silnika. Niektóre harmoniczne przenikają także do sieci zasilającej prądu stałego, co jest kluczowe z punktu widzenia zagadnień kompatybilności elektromagnetycznej. (**Interferencje w trakcyjnym układzie napędowym z silnikami PMSM**)

Keywords: Harmonic Spectrum, Traction Drive, Converter, Public Transport

Słowa kluczowe: widmo częstotliwościowe, napęd trakcyjny, przekształtnik, transport publiczny

Introduction

Nowadays the development of power converters has brought the new conceptions of electric traction drives and also the new conceptions of vehicles. These drives provide high quality to drive systems from the viewpoint of traction, dynamics and energy. Concurrently the problems of side noise effects of power converters have been opened due to this development. These effects are interrelated with high dv/dt and di/dt of power semi-conductor elements used in these converters. The magnitude and type of drive noise effects depend on many elements. It specifically concerns the whole concept of vehicle traction circuits, power converter construction, vehicular electro-equipment assembly, traction circuit parameters (R, L, C), algorithm of control and PWM generation and so on.

The harmonic spectrums of input currents from driving wheel vehicles are analyzed for the reason of possible parasitic effects on railway interlocking devices due to traction circuit operation. In the operation of traction circuits it is necessary to reduce the input current of a vehicle, particularly the harmonic components with frequencies used by interlocking devices. Under the Czech Republic conditions it is necessary to use the particular frequencies, 50 Hz, 75 Hz and 275 Hz. The standards specify the limits of effective values of harmonic components at the defined frequencies. The magnitude limit of harmonic components at traction circuit input is in the range of tens to hundreds of mA. The examples: the track circuit 3111 with receiver EFCP for 75 Hz is limit of 500 mA, the other details are in [1-7]. The problems of interference effects of AC traction drives to feeding network and surrounding devices is very problematic both from viewpoint of theory and experiments. The analytical description of examined systems is solved in [8]. The works were focused on research (on the experimental workplace and simulation) from viewpoint of practical traction applications.

Experimental Workplace

Traction drives with PMSM are most often utilized for an individual drive of wheels or axels in a wheel vehicle. Each drive has to have an own inverter with power switched elements [9]. The inverter input circuit has voltage character and is created by the LC-network. These days at the Department of Electrical and Electronic Engineering and Signaling in Transport at the Jan Perner Transport Faculty (JPTF), University of Pardubice, the research of special characteristics of traction drives with PMSM from the viewpoint of noise effects in low-frequency areas are

performed. The selected significant results of these works are presented in this paper. For research of traction drives, JPTF is equipped with the special laboratory containing traction PMSM: nominal power 58 kW, nominal speed 650 rpm, nominal torque 852 Nm, nominal phase current 122 A, nominal frequency 238 Hz, number of poles 44, the other details are in [10]. The main circuit diagram of this workplace is shown in Fig. 1 and Fig. 2.

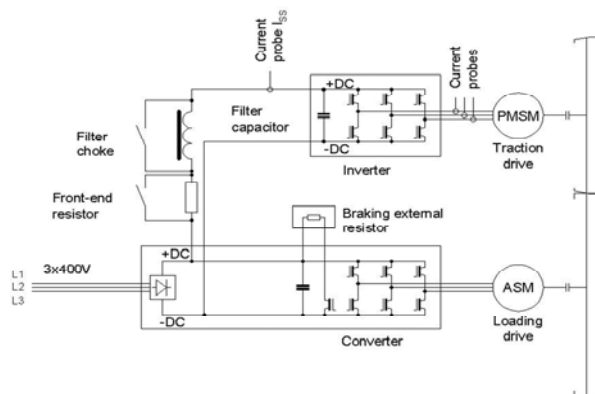

Fig. 1: The power circuit diagram and construction of the experimental workplace

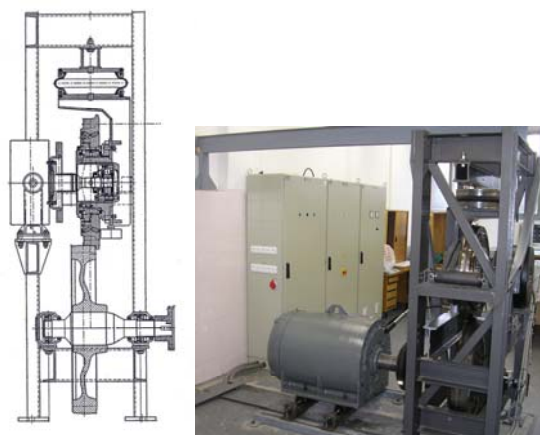

Fig. 2: The construction of the experimental workplace

During research many measurements were done. Their aim was to map out harmonic spectrum of the stator phase currents and currents at the inverter input filter choke of the

traction motor with PMSM at various conception of power circuit diagram and control strategies and effects of these conceptions.

Research of spectrums

The waveform of currents in phases of traction motor and current in input dc circuit of drive were scanned and consequently evaluated at the measurements. The currents were scanned by separated probes (100 kHz). The records and data evaluations were done by the special device with sampling frequency 20 kHz by the Škoda Electric. The PWM inverter switching frequency was 5 kHz. The majority of the measurements were done on a slow ramp represented by a frequency ramp of a converter for an asynchronous motor (load). The PMSM was operated with a torque feedback control.

The analyses of measured waveforms are based on 3D graphs with the time axis (Time), the frequency axis of harmonic component (Frequency) and the axis of effective values of corresponding harmonic component of measured current in mA and A respectively (I_{ef}). The overall view of the frequency spectrum of current in phase of PMSM is shown in Fig. 3. The spectrum map was measured with the load torque (T) of the traction motor at 20 % of nominal values. The fundamental harmonic component of current, whose value is increases following the ramp up to a nominal value 238 Hz, is the most noticeable. The frequency then decreases once again following the ramp.

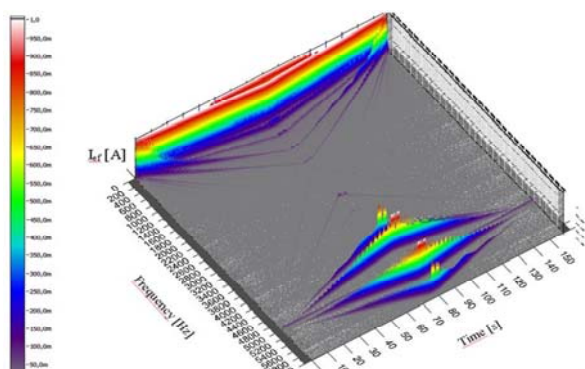

Fig. 3: The spectrum map of phase current of traction motor for T = 20 % and filter parameters L = 5.7 mH, C = 4.7 mF – to 6 kHz

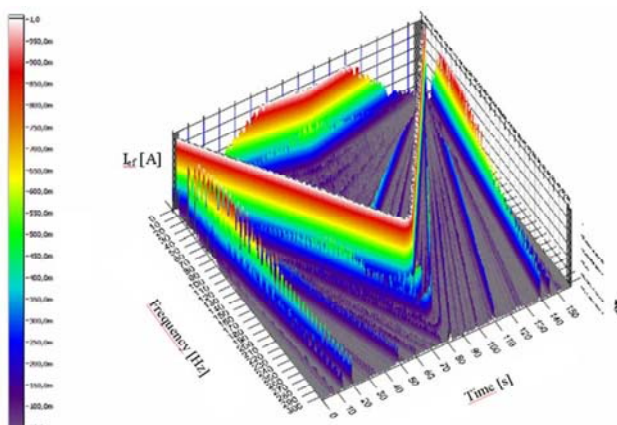

Fig. 4: The spectrum map of phase current of traction motor for T = 20 % and filter parameters L = 5.7 mH, C = 4.7 mF - to 305 Hz

The representation of frequencies related to the PWM frequency of inverter (5 kHz) is evident from the spectrum

map. The frequencies are given by sum and difference of the PWM frequency and double the frequency of fundamental harmonic of current, and further by the sum and difference of PWM frequency and quadruple the frequency of fundamental harmonic of current. The current spectrum in this area is obviously related to the algorithm of PWM generation with variable relative time of switching of inverter transistors in one period of fundamental harmonic, and with the fact that the currents of phases motor are summated in a shared neutral point. Further the 3rd, 5th and 7th harmonic values are presented in the current spectrum. The high effective values of the subharmonic components are also obvious from the spectrum map. The 3rd, 5th and 7th harmonic and also the marked representation of subharmonic components are obvious again in the spectrum detailed in Fig. 4.

The spectrum map of current in the inverter input filter contains only components of low frequencies. Any current component with frequency derived from PWM frequency does not pass in front of the filter, Fig. 5.

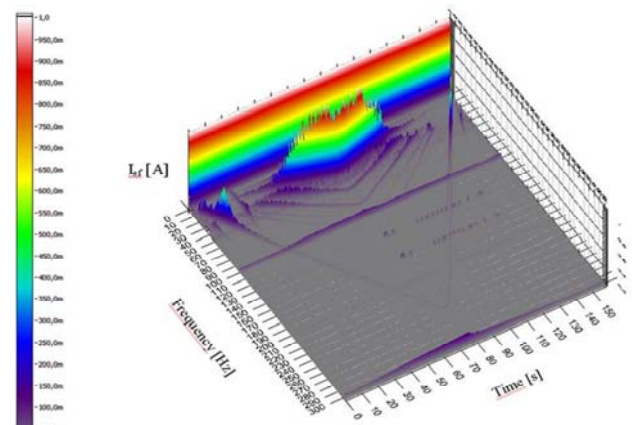

Fig. 5: The spectrum map of current of inverter input filter choke for T = 20 % and filter parameters L = 5.7 mH, C = 4.7 mF – to 305 Hz

In this spectrum, the marked presentation of subharmonic components is evident. The frequencies of these subharmonic components correspond at the certain speed of drive with resonant frequency of inverter input filter $f_{rez} = 30.7$ Hz. For this reason it does not pass by filter operation to their damping but on the other hand to their amplification.

For the most significant effect found out in the research, it was necessary to consider the origin of significant subharmonic components in current spectrums of motor phase. These subharmonic components are transmitted also to the harmonic spectrum of drive DC input currents (through inverter and inverter input filter). It was found out that these subharmonic components originate independently from the magnitude of motor load torque and from drive mode. Near to resonant frequency of inverter input filter, these components are significantly increased and the magnitudes of their effective values are not the same in individual phases of the motor.

The research proceeded to another step whose aim was to map out in more details the causes of origin and effect of subharmonic components in currents of traction drive with low-speed PMSM. The finding of frequency values of significant components in motor currents and in choke currents of inverter input filter was the first step. From research it is obvious that the subharmonic component with the highest effective value has double frequency compared with the frequency of mechanical turns of the motor (it is generated by effect which is repeated twice per mechanical

turn). The findings are unfavorable for this reason, that if low-speed PMSMs are constructed as multipoles and if these drives generate subharmonic components with frequencies from the frequency value of mechanical turns, the harmonic component will have very low frequencies. If the components with these frequencies are presented in input current of drive, their elimination by inverter input filter from the viewpoint of its higher resonant frequency will be very difficult probably.

The frequency detail of the spectrum map of the current of the inverter input filter choke is shown in Fig. 6.

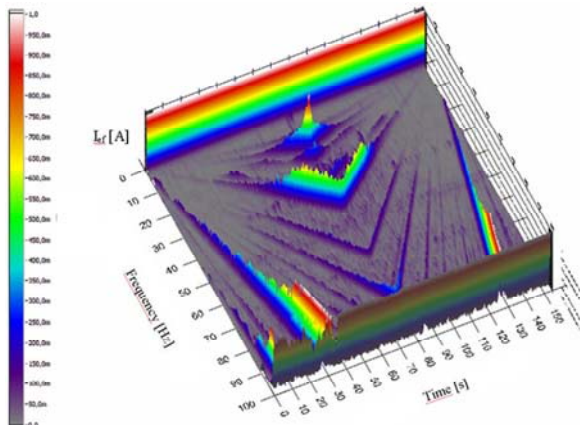

Fig. 6: The spectrum map of current in input filter of inverter for $T=70\%$ and filter parameters $L=1.0\text{ mH}$, $C=4.7\text{ mF}$, detail up to 100 Hz

The frequencies of subharmonic components of current of motor phase and current of input filter choke are not totally the same by effect of the inverter operation; however they have negligible values. For the purpose of authentication the experiments were done (at which the harmonic analysis of induced voltage were done), such that the subharmonic components of drive currents are generated by the effect of fluctuation of an effective value of voltage.

During these experiments, two phase-to-phase induced voltages of stator of traction PMSM were scanned. The phase-to-neutral voltages were not possible to measure because the motor has no central external terminal. The experiment was done so that PMSM was switched off from feeding and its measured induced voltages were terminal voltages at this free-current state. The curve of induced voltage at free idle running of the motor in its reversing state, when the effect of pulse torques occurring in the mechanical or electrical part of the experimental workplace were eliminated, was recorded.

The findings of this experiment are crucial for close localization of the origin of subharmonic components of the drive currents.

The subharmonic components (whose frequencies in large scale correspond with the frequencies of subharmonic components of drive currents) are also significantly interpreted in induced voltages. The subharmonic component with the highest effective value and also with the lowest frequency is a component whose frequency is equal to double the frequency of mechanical turns. The component with this frequency has the highest effective value even in spectrum of phase currents. The other significantly presented subharmonic components are components with frequencies given by multiples of frequency of the highest subharmonic component.

The variation of induced voltage is very slow. However, the effect of this variation to motor currents and also to the drive DC input current is significant from the viewpoint of their harmonic spectrum in the context of the legislative requirements to parameters of currents taken by railway vehicles.

The crucial elimination of determined subharmonic components, which are external to the motor in the electrical part of drive, is very difficult. However finished works indicate that it is necessary to choose resonant frequency of inverter input filter suitably so that it was out of the area of frequencies of the most marked subharmonic components in the whole field of drive speed. This fact moves the resonant frequency of the filter to higher values. For example: the area of resonant frequencies is approximately from 90 up to 120 Hz at the testing drive. This designed filter allows a wider spectrum of harmonic components however the filter resonance with significant subharmonic components would be very adverse.

It is very probable on the basis of these experiments that the reason of origin of subharmonic components is connected with the structure of motor solution: The asymmetry by unequal number of stator and rotor poles, unequal magnetic flux of individual pairs of permanent magnet poles, irregular distribution of permanent magnets over the circumference of the rotor in various directions or motor slot harmonics, whose effects increase just at multipolar low-speed drives are possible theoretical causes.

Conclusion

A lot of measurements have been done at the experimental workplace with various parameters of input filter with the goal to find out effects on harmonic spectrum of drive currents.

- Effect of symmetry of currents in phases of motor - the asymmetry is the most significant, only at selected multiples of subharmonic components with frequency slightly overcrossing the 1st harmonic value. The asymmetry is not significant and it does not even reach 10% at the most unfavorable cases.
- Effect of motor load on harmonic spectrums – The increasing of magnitude of the 1st harmonic leads to exist significant increasing of the 3rd harmonic in the current of motor phase as well. The increasing of motor load by increase of magnitude of components with frequency 300 Hz and by increase of magnitude of subharmonic components in proximity to the filter resonant frequency, finds expression in filter choke current at input inverter.
- Effect of inclusion of a front-end resistor on current spectrum of filter choke - There is a significant attenuation of harmonic components. From this, it is evident that the harmonic spectrum of input current, which a vehicle takes from DC network, will be dependent on the quality of this network i.e. on network ohmic resistors.
- Effect of motor/generator mode - The mode has effect neither on the current spectrum of motor nor on current of input filter choke.
- Effect of inverter dead time on the harmonic spectrum of drive currents, led to the safety time being extended from 4 μs to 8 μs . This extension of dead time found expression in phase current of the motor by frequent increasing of the 5th and the 7th harmonic. The extension of inverter dead time did not occur in the spectrum of input filter choke.

The detection of the existence of unwanted subharmonic components with appreciable effective values of currents at the drive (with low-speed traction PMSM), and the conditions which influence the characteristics of harmonic spectrums of drive currents and the qualification

of the range of possible causes of the origin of these subharmonics, are results of described experiments.

The existence of unwanted subharmonic components can bring serious effects for operation of traction drive. They are not possible to filter by the input filter converter from the viewpoint of low frequency of subharmonic components.

Acknowledgement

The research is supported by the Technology Agency of the Czech Republic under the grant "The research of the driving properties and the control of the drives of the traction rail vehicles with independently rotary wheels", No. TA01030391. The authors thank to TAČR for financial support.

REFERENCES

- [1] J. Novák, J. Šimánek, O. Černý, R. Doleček. EMC of frequency controlled electric drives, *Radioengineering*, vol. 17, no. 4, pp. 101 - 105, December 2008.
- [2] J. Lettl, S. Fígl. Electromagnetic compatibility of matrix converter system, *Radioengineering*, vol. 15, no. 4, pp. 58 - 64, December 2006.
- [3] W. Shepherd, L. Zhang. *Power Converter Circuits*, Taylor and Francis, USA, New York, 2004, ISBN 0-8247-5054-3.
- [4] J. Meng, W. Ma. Power converter EMI analysis including IGBT nonlinear switching transient model. *IEEE Trans. Industrial Electronics*, vol. 53, no. 5, pp. 1577-1583, 2006.
- [5] S. C. Le, J. H. Park. Transfer function-based modelling for voltage oscillation phenomena in PWM motor drives with long feeding cables. *International Journal of Electronics*, vol. 97, pp. 457-473, 2010.
- [6] Standard EN 50121-3-1 Railway applications - Electromagnetic

compatibility, Part 3-1: Rolling stock - Train and complete vehicle

- [7] HILL, R. J., FRACCHIA, M., POZZOBON, P., SCIUTTO, G. A frequency domain model for 3 kV DC traction DCside resonance identification, *Power Systems, IEEE Trans. on*, vol.10, no.3, pp.1369-1375, Aug 1995
- [8] T. Ogawa, S. Wakao, J. Taufiq, K. Kondo, N. Terauchi "Theoretical analysis of cancellation of DC-link current harmonics in the inverter-controlled DC electric railcar", In *Proceedings of the 12th European Conference on Power Electronics and Applications (EPE 2007)*, Denmark, ISBN 978-92-75815-10-8.
- [9] L. Hao. *Permanent magnet AC motor drive system Analysis, design and Application*. VDM Verlag Müller, Germany, 2008, ISBN 978-3-639-07420-8.
- [10] R. Doleček, J. Novák, O. Černý. "Traction Permanent Magnet Synchronous Motor Torque Control with Flux Weakening". *Radioengineering*, vol. 18, no. 4, pp. 601 - 605, December 2009.

Autors: Radovan Doleček, Doc., Jan Perner Transport Faculty, University of Pardubice, Studentská 95, 532 10 Pardubice, Czech Republic E-mail: radovan.dolecek@upce.cz; Ondřej Černý, Ph.D., Jan Perner Transport Faculty, University of Pardubice, Studentská 95, 532 10 Pardubice, Czech Republic E-mail: ondrej.cerny@upce.cz; Jaroslav Novák, Prof., Jan Perner Transport Faculty, University of Pardubice, Studentská 95, 532 10 Pardubice, Czech Republic E-mail: jaroslav.novak@upce.cz; Ing. Mikołaj Bartłomiejczyk Ph. D., Politechnika Gdańska, Wydział Elektrotechniki i Automatyki, Katedra Inżynierii Elektrycznej Transportu, ul. Sobieskiego 7, 80-216 Gdańsk, E-mail: mbartlom@ely.pg.gda.pl