

APARATURA

BADAWCZA I DYDAKTYCZNA

Laboratory bioreactor with pH control system for investigations of hydrogen production in the dark fermentation process

BARTOSZ SZULCZYŃSKI, KAROLINA KUCHARSKA, MARIAN KAMIŃSKI

GDAŃSK UNIVERSITY OF TECHNOLOGY, FACULTY OF CHEMISTRY, DEPARTMENT OF PROCESS
ENGINEERING AND CHEMICAL TECHNOLOGY

Keywords: hydrogen, bioreactor, dark fermentation, pH control system, *Enterobacter aerogenes*

ABSTRACT:

The work presents the construction of a low-cost research bioreactor equipped with a pH control system. The developed bioreactor was applied for hydrogen production in the dark fermentation process using *Enterobacter aerogenes* ATCC 13048. Presented paper compares the results obtained during the process without and with pH regulation for different feed materials: glucose, energetic poplar hydrolysates, acid whey and glycerol. It has been shown that the use of the proposed bioreactor design to study the dark fermentation process is fully justified and purposeful. It has also been observed that the use of pH regulation resulted in a longer log phase of about 12 hours, which increased the amount of hydrogen produced.

Laboratoryjny bioreaktor z systemem kontroli pH do badań nad wytwarzaniem wodoru w procesie ciemnej fermentacji

Słowa kluczowe: wodór, bioreaktor, fermentacja ciemna, system regulacji pH, *Enterobacter aerogenes* ATCC 13048

STRESZCZENIE:

W pracy przedstawiono konstrukcję niskokosztowego bioreaktora badawczego wyposażonego w system kontroli i regulacji pH. Zaprezentowano jego wykorzystanie do badania produkcji wodoru w procesie fermentacji ciemnej z zastosowaniem *Enterobacter aerogenes* ATCC 13048. W pracy porównano wyniki uzyskane przy prowadzeniu procesu bez i z regulacją pH dla różnych materiałów wsadowych: glukozy, hydrolizatów topoli energetycznej, serwatki kwaśnej i glicerolu. Wykazano, że wykorzystanie zaproponowanej konstrukcji bioreaktora do badania procesu fermentacji ciemnej jest w pełni zasadne i celowe. Zaobserwowano również, że zastosowanie regulacji pH powoduje wydłużenie fazy wzrostu wykładniczego o około 12 godzin, co pozwala na zwiększenie ilości wytworzonego wodoru.

1. INTRODUCTION

Hydrogen is widely advocated as an energy carrier for the future [1]. Pure hydrogen does not occur naturally on Earth in large quantities. Therefore, it usually requires a primary energy input to produce hydrogen fuel on an industrial scale. Methods of hydrogen production include fossil fuel reforming (e.g. methane), coal gasification, water electrolysis, photocatalysis, or dark fermentation. The last mentioned method enables a low energy input production of hydrogen from renewable feedstocks [2-6]. Various materials may serve as substrates for hydrogen production, including: glucose, whey, glycerol, energetic poplar, cornstalk, or rice straw. However, efficient fermentative hydrogen production from the above-mentioned substrates is a process sensitive to various parameters, including the composition of the fermentation feed, substrate concentration, oxygen concentration and temperature. Very important process parameter is pH. During bacterial growth, changes in pH occur, as organic acids are produced causing a decrease in pH which affects hydrogen production efficiency. For this reason, the study of the hydrogen production process in the dark fermentation requires a series of fermentations to investigate the influence of these parameters on the hydrogen production efficiency. This work presents a construction of low-cost bioreactor, equipped with a pH control system, suitable for application in the optimization and

screening research of dark fermentation. The effect of pH regulation on the hydrogen production efficiency is presented and discussed.

2. EXPERIMENTAL

2.1 Bioreactor system

The construction of the bioreactor is presented in Figure 1. It is based on a 1200 mL flat-bottomed unjacketed glass vessel. It is hermetically sealed with a 12 mm Teflon® plate cover, silicone rubber o-ring and screwed using aluminum clamps. The vessel is thermally insulated and also protected from external light. Control and regulation of the process temperature (ambient to 280°C) and rotational speed of the stirrer (0-1500 rpm) is ensured by a magnetic stirrer with ceramic-coated plate (Sunlab SU1150, Germany). The temperature signal is transmitted to the stirrer using a Pt1000 sensor.

Anaerobic conditions are ensured by deoxidation using a nitrogen gas stream prior to the fermentation start-up. The compressed nitrogen is introduced using a stainless steel capillary closed with a porous sinter. The concentration of dissolved oxygen in the liquid is monitored using handheld meter (pHenomenal® OX 4100 H, Germany) equipped with galvanic oxygen probe (pHenomenal® OXY11-3, Germany) working in range to 20 mg·L⁻¹ with resolution of 0.1 mg·L⁻¹. The presented bioreactor construction allows for the collection of gaseous and liquid samples.

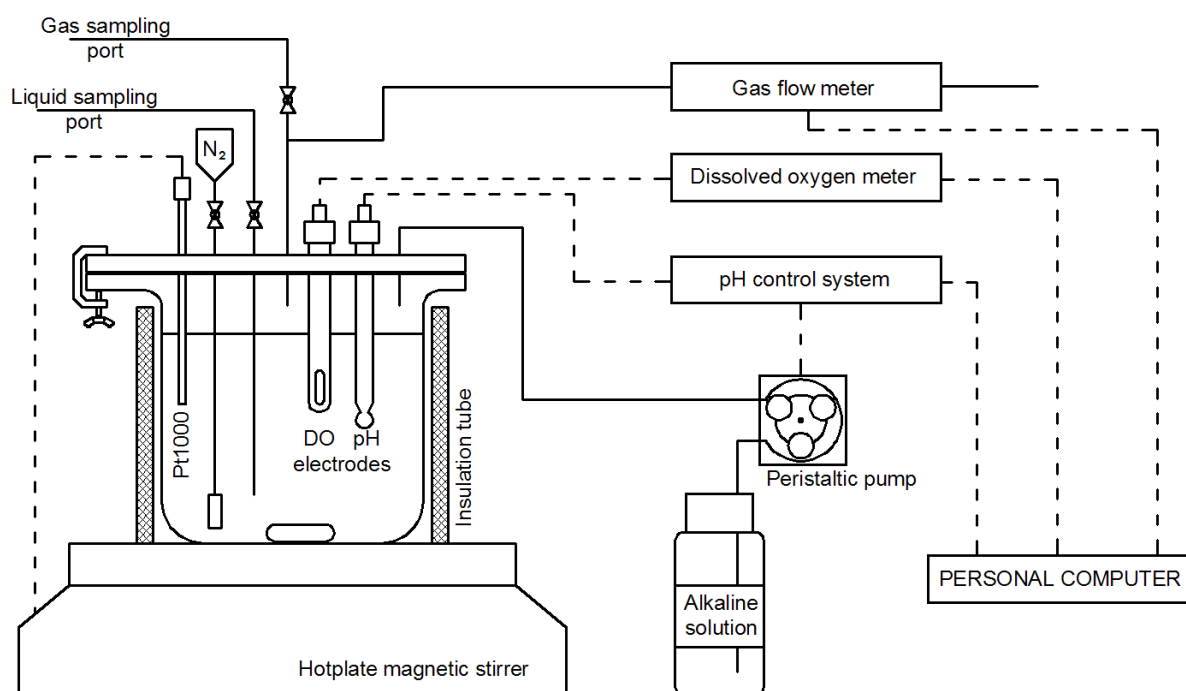

Figure 1 Bioreactor system

Capillary tubes terminated with valves with Luer connectors were used for this purpose. This solution allows for a quick sampling into the syringe, which enables the sample preparation for further stages of analysis (e.g. gas chromatography for hydrogen concentration determination or high-performance liquid chromatography). One of the important parameters describing the dark fermentation process is the amount of gases produced by bacteria. Due to the small capacity of the bioreactor, the amount of gas released is relatively small. For this reason, the volumetric gas flow meter (Agilent Technologies ADM2000, USA) was used. It measures flow rates from 0.5 to 1000 mL·min⁻¹ with accuracy of about ±3%. According to the data presented in Table A.3, the average gas flow rate during the process is in range from 0 to 5 mL·min⁻¹. pH control and regulation is implemented using a self-constructed system. Process parameters (i.e. dissolved oxygen, released gas volume and pH) are sent to the personal computer, where they are presented in the form of graphs and saved using software written in C# (Microsoft Visual Studio). The software also allows integration of the generated gas volume during the process. Data transmission between the devices and the computer is carried out using RS-232 – TTL converters and Arduino MEGA 2560 board, which is responsible for collecting, preparing and transferring data to the computer in online mode.

2.2 pH control system

The scheme of the pH regulation system is presented in Figure 2. It is based on the Arduino platform. As the control unit, the Arduino Mega 2560 board was used. The signal generated by the pH electrode is transmitted to converter module (Gravity: Analog pH Sensor / Meter Pro Kit, DFRobot, China). In this module, the electrode signal is converted to the 0...5 V range signal, which is transmitted to the Arduino Mega 2560 analog-to-digital converter (10 bit). The use of this board allows you to carry out measurements on up to 16 channels. Additionally, thanks to the four independent built-in USART interfaces, it is possible to simultaneously monitor the pH, as well as to receive data from the dissolved oxygen meter and the gas volume meter.

pH regulation is achieved by appropriately prepared software, which allows calibration of the system with the use of pH-standard solutions. As an executive element, low capacity peristaltic pumps were used. The pump doses the alkaline solution (during the pH is decreasing), which is introduced using a capillary located in the bioreactor cover. Adjustment of the volume of the dosed base solution to the bioreactor was obtained using a variable rotation speed of the electric motor driving the pump. For this purpose, Pulse Width Modulation (PWM) technique linked with N-MOSFET transistor was used. The scheme of the program implementing the pH regulation is shown in the Figure 3.

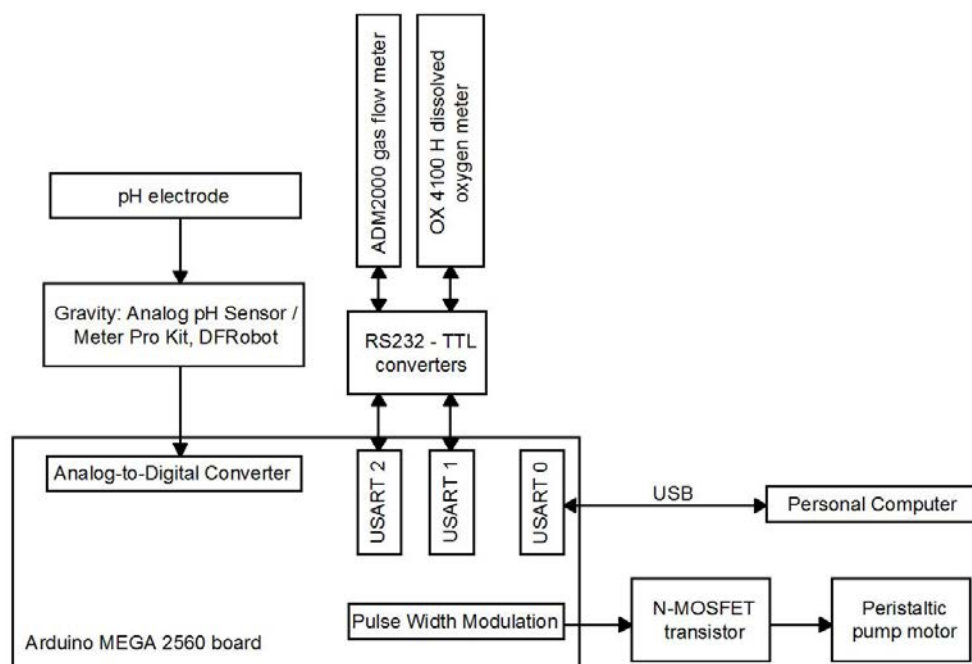

Figure 2 Block diagram of pH control system

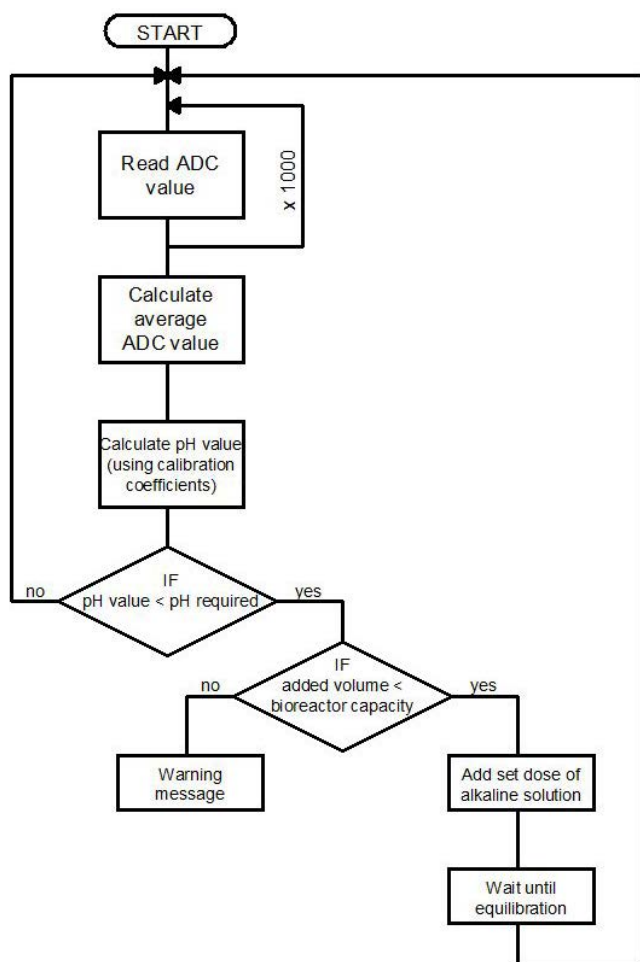

Figure 3 Software block diagram of pH control system

The user can manipulate the settings: required pH value, the volume dispensed once to the bioreactor and the minimum time between successive dosages (this time is necessary for entering the system into equilibrium state after adding the base solution to the bioreactor). The user enters the initial volume of the liquid in the bioreactor. The software counts the total volume of the dosing solution, and if it approaches the total volume of the bioreactor (1200 mL), it informs the user and does not allow for further addition of a base solution to the bioreactor.

2.3 Dark fermentation

Enterobacter aerogenes ATCC 13048 (Selectrol TCS Biosciences Ltd.) was used for hydrogen production in the dark fermentation process in sterile 1200 mL glass bioreactors with initial working volume equal to 1 liter under regulated pH conditions and non-regulated pH conditions for comparison purposes. The initial fermentation broth was composed of Thioglycollate Peptone Water (Biomaxima) and glucose, energetic poplar hydrolysates, acid whey or glycerol (concentration

of carbon source equal to 5.5 g per L). The initial pH of the fermentation broth was adjusted to 7.00 with 1 M NaOH. Bioreactors were inoculated with 50 mL of *Enterobacter aerogenes* ATCC 13048 culture in a liquid breeding at the optical density $OD_{\lambda=600nm} = 2.400 \pm 0.125$. Processes were carried out in triplicates. The presented results are randomized. Anaerobic conditions were created by purging the reactors with sterile nitrogen gas for 60 min. Operational set-points were as follows: 37°C, 320 rpm, 7.00 ± 0.10 for temperature, agitation and pH, respectively. Fermentation time of 72 h was applied, as it corresponds to the late logarithmic death phase of *Enterobacter aerogenes* ATCC 13048 culture [7-9] temperature, pre-treatment time and granulation. For this purpose, experiments were carried out in accordance to the Box-Behnken design for four factors. In the saccharification process of the pre-treated biomass, cellulolytic enzymes immobilized on diatomaceous earth were used. Based on the obtained results, a mathematical model for the optimal conditions of alkaline pre-treatment prediction is proposed. The optimal conditions of alkaline pre-treatment are established as follows: granulation 0.75 mm, catalyst concentration 7%, pre-treatment time 6 h and temperature 65°C if the saccharification efficiency and cost analysis are considered. An influence of the optimized pre-treatment on both the chemical composition and structural changes for six various lignocellulosic materials (energetic willow, energetic poplar, beech, triticale, meadow grass, corncobs).

3. RESULTS AND DISCUSSION

Hydrogen production experiments are based on the mesophilic dark fermentation [10, 11] technique carried out periodically in triplicates under anaerobic conditions. Hydrogen production is a sensitive process, because it strongly depends on many factors, including the composition of the fermentation feed, substrate concentration, oxygen concentration and temperature. Selected process parameters were monitored during the experiment. The values of temperature and oxygen concentration during the fermentation process are presented in Appendix (Tables A.1, A.2, respectively). Changes occurring in the fermentation broth in pH-controlled and pH-non-controlled systems are presented in Table 1 for different feed materials.

Table 1 Changes in pH occurring during dark fermentation for different feed materials

Time [h]	Glucose pH un-controlled	pH, ± 0.02				
		Glucose	Blank	Energetic poplar	Whey	Glycerol
		pH controlled				
0	7.05	7.05	7.02	7.05	7.05	7.05
1	7.05	7.05	7.04	7.05	7.05	7.04
2	7.04	7.04	7.02	7.04	7.04	7.05
3	7.05	7.05	7.02	7.05	7.05	7.01
4	6.78	7.01	7.03	7.01	7.01	7.05
5	6.24	7.06	7.03	7.05	7.04	7.05
6	6.18	7.02	7.05	7.05	7.05	7.04
7	5.92	7.01	7.03	7.04	7.01	7.05
16	5.90	7.00	7.05	7.05	7.06	7.01
18	5.78	7.05	7.05	7.01	7.00	7.04
20	5.76	7.05	7.05	7.06	7.01	7.05
24	5.62	7.04	7.04	7.02	7.00	7.01
28	5.59	7.05	7.05	7.01	7.05	7.06
32	5.54	7.01	7.01	7.00	7.05	7.02
36	5.41	7.05	7.06	7.05	7.05	7.05
48	5.04	7.05	7.02	7.05	7.05	7.05
52	4.99	7.04	7.01	7.04	7.04	7.04
68	5.02	7.05	7.00	7.05	7.05	7.05
72	4.89	7.01	7.05	7.01	7.01	7.01

The changes in the optical density $OD_{\lambda=600nm}$ of *Enterobacter aerogenes* ATCC 13048 cultures in bioreactors as well as the course of hydrogen volume generation were investigated and compared. The results are presented in Figures 4 and 5, respectively. Supplementary material concerning the accretion of total gas volume is provided in appendix (Table A.3.).

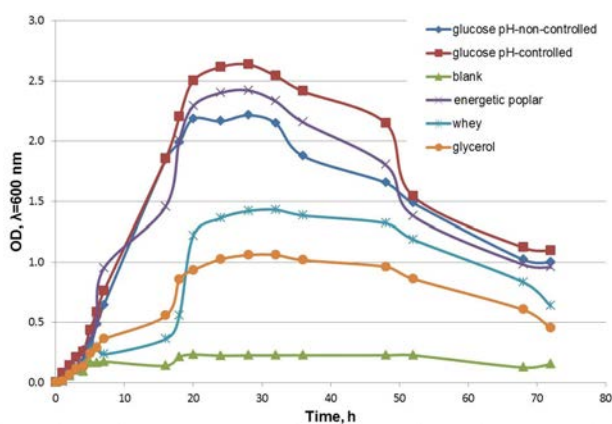

Figure 4 Changes in optical density of bacterial cultures occurring during *E. aerogenes* ATCC 13048 growth during the dark fermentation process for different feed materials

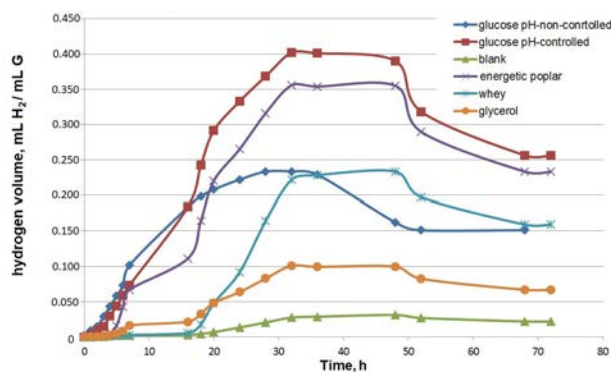

Figure 5 Changes in volume of hydrogen generated in dark fermentation for different feed materials

The process of microbial growth over time can be represented by the bacterial growth curve, with clearly distinguishable four phases, i.e. the phase of primary inhibition when there is adaptation to new environmental conditions; exponential growth phase when the number of cells increases rapidly; stable growth phase – approximately the number of cells forming and dying at a given moment. This phase occurs when the food sources start to deplete and/or the concentration of metabolic products increases to a level that is harmful to the bacteria themselves; the terminal

phase when the cell death processes dominates. In Figure 4, changes in the optical density during microbial culture can be clearly observed and all mentioned phases occurred. It can be observed, that the stable growth phase is longer when the pH control system is applied in glucose broths. Using non-glucose sole carbon sources i.e. whey, glycerol or lignocellulosic biomass feedstock, causes an elongation of the primary inhibition phase. Data presented in Figure 5 correspond to the course of bacterial growth (Fig. 4.). The amount of hydrogen in the overall gas stream (mL H₂/mL G) increases and decreases proportionally to the microbial growth phase. Therefore, it can be concluded that there is a strong relationship between the growth of microbial culture (Fig. 4), which is directly affected by the use of the pH control system and the efficiency of hydrogen production.

Optimal growth conditions of *Enterobacter aerogenes* ATCC 13048 [12] are declared in the pH range of 6.8-7.2. During bacterial growth, changes in pH occur, as acetic, succinic and formic acids [13-17] are formed causing further decrease in pH. The analysis of the hydrogen production curve by *Enterobacter aerogenes* ATCC 13048 revealed, that the efficiency of hydrogen formulation can be increased, when the pH is controlled and set at 7.00 and glucose is used as a sole carbon source. It can also be observed, that the log phase lasts ca. 12 h longer when pH-control system is applied in glucose-based broths. Therefore, pH-control conditions were applied during the dark fermentation of energetic poplar hydrolysates, obtained according to [7], acid whey solution or glycerol solution. Certain differences can be observed for dark fermentation of different feed materials.

4. CONCLUSIONS

The paper presents the construction of a low-cost research bioreactor equipped with a pH control system. The design of the bioreactor is based on easily accessible elements, which makes it extremely easy to adapt its equipment to carry out specific biotechnology processes. The presented system allows monitoring and control of the basic parameters of the fermentation process i.e. temperature, dissolved oxygen concentration, pH and generated gas volume. Thanks to the Arduino platform, the above-mentioned parameters are sent to the personal computer, presented graphically and stored. Such an approach makes the presented bioreactor suitable for didactics purposes.

In the proposed bioreactor type, a series of studies on the production of hydrogen during the dark fermentation has been carried out. It has been shown that the use of the proposed bioreactor design is fully justified and purposeful. Due to the possibility of visualization of the changes in the process parameters in the on-line mode and a simple gas and liquid sampling system, the execution of screening or optimization studies becomes extremely simple. Presented studies of dark fermentation process using *Enterobacter aerogenes* ATCC 13048, indicates a large dependence of the volume of hydrogen on pH of the fermentation broth. Providing the correct pH range using a pH control system results in a longer log phase of about 12 hours, which increased the total amount of hydrogen produced.

Acknowledgements: This work was carried out within the framework of the project "Studies of alkaline hydrolysis of lignocellulosic biomass and conversion conditions of hydrolyzed products to biogases", supported financially by the National Science Center through the grant UMO-2014/13/B/ST8/04258.

Conflicts of Interest: The authors declare no conflict of interest. The founding sponsors had no role in the design of the study; in the collection, analyses, or interpretation of data; in the writing of the manuscript, and in the decision to publish the results.

REFERENCES

- [1] Rubio M. G. A., Jaojaruek K., Hydrogen – The Future Fuel, *Adv Automob Eng*, 4 (2015), 116.
- [2] Dincer I., Acar C., Review and evaluation of hydrogen production methods for better sustainability, *Int J Hydrogen Energy*, 40 (2015), 11094-11111.
- [3] Pakarinen O., Lehtomäki A., Rintala J., Batch dark fermentative hydrogen production from grass silage: The effect of inoculum, pH, temperature and VS ratio, *Int J Hydrogen Energy*, 33 (2008), 594-601.
- [4] Gadhe A., Sonawane S. S., Varma M. N., Enhanced biohydrogen production from dark fermentation of complex dairy wastewater by sonolysis, *Int J Hydrogen Energy*, 40 (2015), 9942-9951.
- [5] Hu C. C., Giannis A., Chen C. L., Qi W., Wang J. Y., Comparative study of biohydrogen production by four dark fermentative bacteria, *Int J Hydrogen Energy*, 38 (2013), 15686-15692.
- [6] Reilly M., Dinsdale R., Guwy A., Mesophilic biohydrogen production from calcium hydroxide treated wheat straw, *Int J Hydrogen Energy*, 39 (2014), 16891-16901.
- [7] Kucharska K., Łukajtis R., Słupek E., Cieśliński H., Rybarczyk P., Kamiński M., Hydrogen Production from Energy Poplar Preceded by MEA Pre-Treatment and Enzymatic Hydrolysis, *Molecules*, 23 (2018), 1-21.
- [8] Łukajtis R., Rybarczyk P., Kucharska K., Konopacka-Łyskawa D., Słupek E., Wychodnik K., Kamiński M., Optimization of saccharification conditions of lignocellulosic biomass under alkaline pre-treatment and enzymatic hydrolysis, *Energies*, 11 (2018), 886.
- [9] Łukajtis R., Kucharska K., Hołowacz I., Rybarczyk P., Wychodnik K., Słupek E., Nowak P., Kamiński M., Comparison and Optimization of Saccharification Conditions of Alkaline Pre-Treated Triticale Straw for Acid and Enzymatic Hydrolysis Followed by Ethanol Fermentation, *Energies*, 11 (2018), 639.
- [10] Krishnan S., Singh L., Sakinah M., Thakur S., Nasrul M., Otieno A., Wahid Z. A., An investigation of two-stage thermophilic and mesophilic fermentation process for the production of hydrogen and methane from palm oil mill effluent, *Environ Prog Sustain Energy*, 36 (2017), 1322-1336.
- [11] Kucharska K., Hołowacz I., Konopacka-Łyskawa D., Rybarczyk P., Kamiński M., Key issues in modeling and optimization of lignocellulosic biomass fermentative conversion to gaseous biofuels, *Renew Energy*, 129 (2018), 384-408.
- [12] Reungsang A., Sittijunda S., O-Thong S., Bio-hydrogen production from glycerol by immobilized *Enterobacter aerogenes* ATCC 13048 on heat-treated UASB granules as affected by organic loading rate, *Int J Hydrogen Energy*, 38 (2013), 6970-6979.
- [13] Nath K., Muthukumar M., Kumar A., Das D., Kinetics of two-stage fermentation process for the production of hydrogen, *Int J Hydrogen Energy*, 33 (2008), 1195-1203.
- [14] Chaganti S. R., Kim D. H., Lalman J. A., Dark fermentative hydrogen production by mixed anaerobic cultures: Effect of inoculum treatment methods on hydrogen yield, *Renew Energy*, 48 (2012), 117-121.
- [15] Slezak R., Grzelak J., Krzystek L., Ledakowicz S., The effect of initial organic load of the kitchen waste on the production of VFA and H₂ in dark fermentation, *Waste Manage*, 68 (2017), 610-617.
- [16] Bundhoo M. A. Z., Mohee R., Inhibition of dark fermentative bio-hydrogen production: A review, *Int J Hydrogen Energy*, 41 (2016), 6713-6733.
- [17] Singh L., Wahid Z. A., Siddiqui M. F., Ahmad A., Rahim M. H. A., Sakinah M., Application of immobilized upflow anaerobic sludge blanket reactor using *Clostridium* LS2 for enhanced biohydrogen production and treatment efficiency of palm oil mill effluent, *Int J Hydrogen Energy*, 38 (2013), 2221-2229.

APPENDIX

Table A.1 Changes in temperature occurring during dark fermentation for different feed materials

Time [h]	Temperature, °C					
	Glucose pH uncontrolled	Glucose	Blank	Energetic poplar	Whey	Glycerol
0	37.2	37.0	37.0	37.0	37.0	37.0
1	37.1	36.9	37.3	36.8	36.8	36.7
2	36.8	37.2	36.4	37.1	36.9	36.6
3	37.1	37.1	36.7	37.0	36.9	36.7
4	37.4	36.8	36.4	36.7	37.0	36.9
5	36.5	37.1	36.6	37.0	36.8	36.9
6	36.8	37.4	36.7	37.3	36.7	37.0
7	37.0	36.5	36.6	36.4	36.6	36.9
16	37.3	36.8	36.7	36.7	36.7	36.8
18	36.4	36.5	36.9	36.4	36.8	36.9
20	36.7	36.7	36.9	36.6	36.8	36.9
24	36.4	36.8	37.0	36.7	36.9	37.0
28	36.6	36.9	36.9	36.8	36.9	36.8
36	36.8	37.0	36.8	36.9	36.8	36.9
48	36.9	37.0	36.9	36.9	36.7	36.9
68	36.7	36.7	36.7	36.9	36.8	36.9
72	37.5	37.1	37.5	37.1	37.1	37.1

Table A.2 Changes in oxygen concentration occurring during dark fermentation for different feed materials

Time [h]	Concentration of oxygen, mg O ₂ /L					
	Glucose pH uncontrolled	Glucose	Blank	Energetic poplar	Whey	Glycerol
0	0.0	0.0	0.0	0.0	0.0	0.0
1	0.0	0.0	0.0	0.1	0.0	0.0
2	0.0	0.0	0.0	0.0	0.0	0.0
3	0.0	0.0	0.0	0.0	0.0	0.0
4	0.0	0.1	0.0	0.2	0.0	0.0
5	0.0	0.0	0.0	0.1	0.0	0.0
6	0.0	0.2	0.0	0.1	0.1	0.0
7	0.1	0.1	0.0	0.1	0.1	0.0
16	0.0	0.1	0.1	0.1	0.1	0.1
18	0.0	0.0	0.1	0.1	0.0	0.1
20	0.0	0.0	0.1	0.3	0.0	0.1
24	0.0	0.0	0.1	0.3	0.0	0.1
28	0.0	0.0	0.1	0.3	0.0	0.1
36	0.1	0.0	0.1	0.3	0.0	0.1
48	0.0	0.1	0.1	0.2	0.0	0.1
68	0.2	0.0	0.1	0.1	0.1	0.0
72	0.2	0.1	0.1	0.1	0.1	0.0

Table. A.3 Changes in accretion of gas volume occurring during dark fermentation for different feed materials

Time [h]	Glucose pH uncontrolled	Accretion of gas volume ± 40 ml, ml				
		Glucose	Blank	Energetic poplar	Whey	Glycerol
		pH controlled				
0	0.00	0.00	0.00	0.00	0.00	0.00
1	24.98	25.20	0.09	12.32	0.59	1.77
2	87.22	86.99	3.28	14.32	1.42	2.82
3	121.13	124.20	4.20	20.23	5.10	9.95
4	241.51	235.73	11.68	32.25	8.6	20.79
5	318.44	336.31	13.11	125.30	10.23	33.95
6	376.41	412.72	14.04	301.20	11.40	53.14
7	385.22	476.08	14.13	433.23	15.26	96.36
16	411.25	653.00	14.35	594.23	26.55	103.88
18	434.21	688.88	15.76	626.88	49.30	113.27
20	462.14	728.89	17.06	663.29	65.12	120.06
24	511.05	769.68	21.07	700.41	137.60	138.75
28	555.52	799.22	36.40	727.29	228.99	158.34
36	562.12	870.13	59.20	791.82	436.81	198.35
48	571.03	876.16	64.30	797.31	462.13	203.09
68	596.28	899.20	75.50	818.27	506.63	211.35
72	596.44	899.22	76.30	818.29	507.42	212.70