

Limited selectivity of amperometric gas sensors operating in multicomponent gas mixtures and methods of selectivity improvement

M. DMITRZAK^{1,2*}, P. JASIŃSKI¹, G. JASIŃSKI¹

¹ Faculty of Electronics, Telecommunications and Informatics, Gdansk University of Technology, ul. G. Narutowicza 11/12, 80-233, Gdansk, Poland

² PM Ecology sp. z o. o., Letniskowa 28A, 80-299, Gdansk, Poland

Abstract. In recent years, smog and poor air quality have become a growing environmental problem. There is a need to continuously monitor the quality of the air. The lack of selectivity is one of the most important problems limiting the use of gas sensors for this purpose. In this study, the selectivity of six amperometric gas sensors is investigated. First, the sensors were calibrated in order to find a correlation between the concentration level and sensor output. Afterwards, the responses of each sensor to single or multicomponent gas mixtures with concentrations from 50 ppb to 1 ppm were measured. The sensors were studied under controlled conditions, a constant gas flow rate of 100 mL/min and 50 % relative humidity. Single Gas Sensor Response Interpretation, Multiple Linear Regression, and Artificial Neural Network algorithms were used to predict the concentrations of SO₂ and NO₂. The main goal was to study different interactions between sensors and gases in multicomponent gas mixtures and show that it is insufficient to calibrate sensors in only a single gas.

Key words: gas sensor; amperometric sensor; cross-sensitivity; multiple linear regression; artificial neural networks

1. Introduction

Poor air quality has not only a significant impact on the health of the human population, particularly in urban areas, but also on the economy, increasing medical costs, cutting lives short and reducing productivity. Air pollution is also very dangerous to vegetation and ecosystems. It has a devastating effect on water and soil, contributing to the destruction of fauna and flora. The most harmful air pollutants for the ecosystem are ozone, ammonia and nitrogen oxides which introduce an excess of nutrient nitrogen. Nitrogen oxides and sulphur dioxide lead to soil, rivers and lake acidification and acid rain, resulting in biodiversity loss.

Despite reductions in emissions and ambient concentrations, air quality still remains poor in multiple areas, when it comes to Europe. According to the European Environment Agency [1], the premature deaths attributed to PM_{2.5}, NO₂ and O₃ were 412,000, 71,000 and 15,100 people, respectively, in 2016. The countries with the highest numbers of premature deaths and years of life lost are Germany, Italy, Poland, France, Spain and the United Kingdom.

For environmental protection, it is very important to measure the level of pollution in the air. On the market, there is a wide range of commercial gas sensors. The most popular are metal oxide semiconductor sensors (MOX) whose output signal is based on a change of conductivity of the oxide that is caused by a reaction with volatile compounds [2]. Unfortunately, this type of sensor has poor selectivity and is sensitive to almost any volatile substances. Its sensitivity can be enhanced by changing the grain size and porosity, and adding impurities and dopants, but it decreases with higher humidities of the

environment [3]. MOX sensors also have low reproducibility due to their manufacturing process [4]. They are not single-gas selective and one MOX sensor is not able to detect a gas concentration in a gas mixture [5]. Such sensors, due to their low cost and availability, are often used in multisensor arrays; so-called electronic noses (e-nose) [6-8].

A very interesting solution is the use of ZnO and TiO₂ nanostructures for NO₂ detection [9]. TiO₂ can detect low concentrations of this gas, but its sensitivity is very dependent on the humidity of the atmosphere. ZnO is less sensitive to changes in humidity, but it is not able to accurately determine the concentration of NO₂. It is characterised by fast desorption and thus the combination of TiO₂ and ZnO structures allows the detection and disappearance of NO₂ gas in a short time. The effect of air humidity on the sensitivity of the sensors can be minimised with the help of dehumidifiers.

Application of a graphene sensing layer allows very low concentrations of toxic gases to be measured. It has been demonstrated that graphene sensors are able to detect every single molecule of nitrogen dioxide [10, 11].

Current research focuses on gas-sensitive materials and pattern recognition development [12]. It has been revealed that a multisensor array in combination with machine learning algorithms is a promising way to get a fast analysis of, e.g. air contaminants or food flavours and odours, so it can be used to verify its quality [7, 13-16].

Gas detection and classification is a major problem in many industries. One method that works well with these types of tasks is to use a neuro-fuzzy network [17]. The modified Takagi-Sugeno-Kang network structure proposed by Osowski, Brudzewski and Tran Hoai is suitable for solving regression and classification problems with multidimensional data.

*e-mail: marta.dmitrzak@pmecology.com

Amperometric sensors are more selective and stable, and have a fast recovery time. This type of gas sensor consists of an electrolyte and three electrodes. The gas molecules are reduced or oxidised at the working electrode, while the opposite reaction takes place at the counter electrode. The output signal is measured as a current generated by a reaction between the gas and an analyte [18].

A very important parameter of gas sensors is cross-sensitivity caused by interfering gases. Information provided by manufacturers in data sheets is declared only for selected conditions and often differ from the real-life properties of the sensors. Cross-interference is often a cause of false sensor readings [19]. That is why a laboratory evaluation of sensor properties is needed. For example, it is very hard to differentiate nitrogen dioxide and ozone because these types of molecules get reduced at electrodes that are made of gold or carbon at much the same potentials [20].

Interpretation of the responses of a gas sensor is usually done using a simple method, hereinafter referred to as Single Gas Sensor Response Interpretation (SGS). In this approach, the gas concentration is calculated only on the basis of the target sensor and its declared sensitivity to this gas type. This method does not give accurate results, because the presence of other gases often increases or reduces the target sensor response. Therefore, in order to do the calibration properly, we should also use sensors of other gas types and take into account their interaction. Presumably, better performance can be achieved by setting up algorithms such as Multiple Linear Regression or Artificial Neural Networks and training them in multicomponent mixtures.

The first objective of this study was to determine how gas sensors react to the presence of the gases they are constructed to detect, including in other gases including multicomponent gas mixtures. The second task of the work was to prove that due to the sensors' cross-sensitivities, calibration of sensors in gas mixtures rather than in single gases provides better results. The main goal was to study different interactions between sensors and gases in multicomponent gas mixtures and show that it is insufficient to calibrate sensors in only a single gas. The text contains exemplary results for SO₂ and NO₂.

2. Experimental

The measurements were performed in a custom-designed chamber having a volume of 240 cm³. Six commercially available amperometric gas sensors were placed in this chamber. The results for sensors manufactured by one of the leaders in gas sensing technology, namely S1-H₂S, S2-O₃, S3-NO, S4-SO₂, S5-NO₂ and S6-CO which detect H₂S, O₃ and NO₂, NO, SO₂, NO₂ and CO, respectively, are described in this text. Amperometric sensors have to be controlled by a potentiostatic circuit to

work properly at a fixed potential. Ten custom-designed electronic modules forming the measuring system were used for sensor response acquisition. More details of the developed systems were presented elsewhere [21, 22]. The sensor response was measured by custom-written PC software once per minute and saved to a text file.

The gas-delivery system consisted of four Brooks GF40 mass flow controllers (MFCs) connected to the computer via an RS-485 interface (Fig. 1). The flow rate range of MFCs was: 250 sccm, 250 sccm, 12 sccm and 12 sccm with accuracy ±1% of set point at 35–100% of its range, or ±0.35% of full scale at 2–35% of its range. The flow of gas was programmed with the Medson software. The desired gas mixture was obtained by mixing and diluting gases from reference cylinders with synthetic air. In order to make the gas mixtures, four ALPHAGAZ™ cylinders containing high-purity gases were used (Table 1). The measurements were carried out under controlled gas concentrations, a constant air flow rate of 100 ml/min and 50% relative humidity conditions.

For the sensitivity calculation, the synthetic air gas was used for about 3 hours, then the sensors were flushed alternately with synthetic air and a fixed value of specific toxic gas concentration (from 50 ppb to 1 ppm) for 4 hours. Multicomponent gas mixtures were measured for 2 pairs of two toxic gases, SO₂ and NO₂, SO₂ and NO, NO₂ and NO. Between changes of the type of the toxic gases, the sensors were flushed with synthetic air to clear any residual toxic gas from the measurement chamber.

Two experimental sequences were used. The first sequence consisted of synthetic air alternately with 1 ppm of the first toxic gas, 1 ppm of the second toxic gas, and 1 ppm of both gases at the same time. The second sequence consisted of synthetic air alternately with the first and second toxic gas in a balance of 250 ppb : 750 ppb, 500 ppb : 500 ppb, and 750 ppb : 250 ppb. These sequences were repeated two times. Concentrations of SO₂ and NO₂ have been determined, NO was used as a disturbing gas.

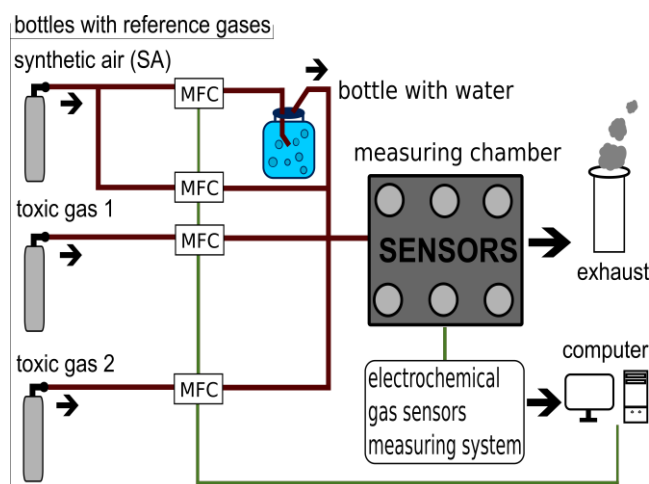

Fig. 1. Structure of the measuring stand.

Table 1
Data of used gas cylinders.

Type of gas	Components / Nominal concentration	Uncertainty ± [%]	Quality
Synthetic air	80% N ₂ , 20% O ₂	1	N 50
SO ₂	10 ppm SO ₂	3	N 45
NO ₂	10 ppm NO ₂	3	N 25
NO	50 ppm NO	3	N 25

3. Methods

After dispensing a gas into the chamber, it was possible to set up training algorithms to quantify the components of the mixture. Prediction of the gas concentration was carried out by three methods: Single Gas Sensor Response Interpretation (SGS), Multiple Linear Regression (MLR), and Artificial Neural Networks (ANN). Scripts written in Python and MATLAB were used to make such analyses.

The total dataset consisted of 900 measurement points which was divided into 60% for the training set, with the remaining 40% being a testing set. The training set contained 540 points: 180 and 360 points were measured in single and binary gases, respectively. The test data was collected a few months after the training data.

3.1. Single Gas Sensor Response Interpretation (SGS).

The first method allowed us to predict the 'ideal sensor' toxic gas concentration, namely, assuming that the sensor is ideal and reacts only with the target gas. Values were obtained by (1):

$$C_{SGS} = \frac{I_{sens}}{S_{calc}}, \quad (1)$$

where I_{sens} - sensor response in nA; S_{calc} - calculated sensitivity.

This model uses only one independent variable, which is the response of the sensor, divided by its sensitivity.

3.2. Multiple Linear Regression (MLR).

This is very similar to Simple Linear Regression, but it takes more than one explanatory variable. It includes all sensor responses with calibration parameters according to (2):

$$C_{MLR} = \beta_0 + \beta_1 x_1 + \beta_2 x_2 + \dots + \beta_6 x_6, \quad (2)$$

where $\beta_{0...6}$ - calibration parameters; $x_{1...6}$ - sensor response (independent variables).

The performance of prediction can be significantly improved by finding the linear relationship between one dependent variable, which represents the gas concentration and several independent variables (sensor responses).

3.3. Artificial Neural Networks (ANN).

In this work, a Multi-layer Perceptron model was used to quantify the toxic gas concentration. The number of neurons in the input layer was equal to the number of sensors ($N = 6$), and output layer consisted of 1 neuron (target gas concentration). The number of hidden layers ($l = 2$) and hidden neurons ($n = 7$) was experimentally chosen to achieve the best accuracy determined by performance metrics, however similar results were obtained for other network architectures.

The Levenberg-Marquardt backpropagation algorithm was used to train the networks. The initial weights have been selected randomly. Tanh transfer function was used to activate neurons.

3.4. Model performance.

The performances of all of the algorithms were determined by several criteria, such as coefficient of determination (R^2), Root Mean Squared Error (RMSE) and Mean Absolute Error (MAE), which are shown in Table 2. The higher R^2 , the better the model, in contrast to RMSE and MAE (which is less sensitive to outliers than RMSE) values.

Table 2

Evaluation metrics of model performance; n is a number of measurement points, y is a vector of reference values, p is a vector of values of predicted concentrations, and i is an actual measurement point

Metric	Symbol	Formula
Coefficient of determination	R^2	$1 - \frac{\sum_{i=1}^n (y_i - p_i)^2}{\sum_{i=1}^n (y_i - \bar{y})^2}$
Root Mean Squared Error	RMSE	$\sqrt{\left(\frac{1}{n}\right) * \sum_{i=1}^n (y_i - p_i)^2}$
Mean Absolute Error	MAE	$\left(\frac{1}{n}\right) * \sum_{i=1}^n y_i - p_i $

4. Results

The sensitivity of the sensors was investigated by measuring their response with a gradually increased concentration of target gases. Fig. 2 and Fig. 3 present time courses of sensors' responses to different SO₂ and NO₂ concentrations. Usually, for most sensors, an increased presence of each gas caused an increased response of all sensors. For example, the presence of SO₂ resulted in a significant response from the SO₂ sensor, but also from the H₂S sensor. Such behaviour confirms the lack of selectivity of this kind of sensors.

15-minute averages of the curve parts once the response stabilised (i.e. before the new gas concentration was introduced into the chamber) were used to calculate the response of the sensors to a given concentration of SO₂ and NO₂ according to (1), which is graphically presented in Fig. 4 and Fig 5, respectively. The

experiment was repeated for all toxic gases (not shown here). The sensors' response almost linearly depended on the concentration of the measured gases. The slope of the response was used to calculate the sensor's sensitivity (Table 3). Generally, the obtained numbers are within the range declared by the manufacturer. As can be seen, the measured sensitivity of S1-H₂S and S5-NO₂ slightly differ from the information on their datasheets.

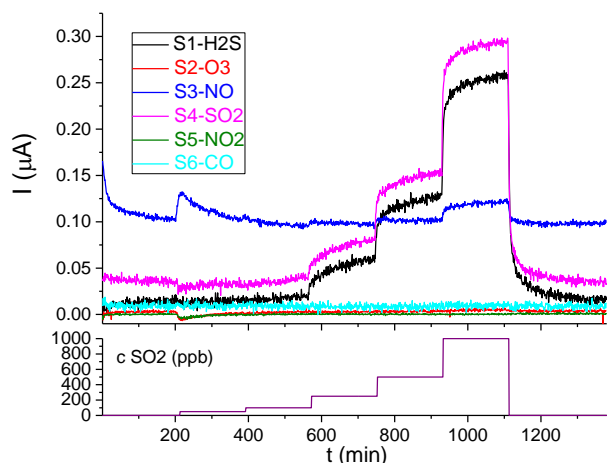

Fig. 2. Sensors response to different concentrations of SO₂.

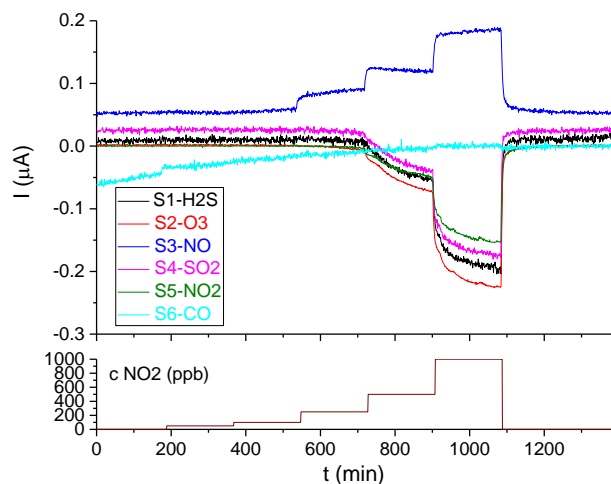

Fig. 3. Sensors response in given concentrations of NO₂.

Table 3

Comparison of calculated sensors' sensitivity values and sensitivities provided by datasheets.

Sensor model	Calculated sensitivity [nA/ppm]	Datasheet sensitivity [nA/ppm]
S1-H ₂ S	1120.08 ± 26.92	1450 ÷ 2150
S2-O ₃	-322.47 ± 5.74	-650 ÷ -225
S3-NO	544.55 ± 78.53	500 ÷ 850
S4-SO ₂	278.70 ± 4.08	275 ÷ 475
S5-NO ₂	-166.13 ± 20.05	-450 ÷ -175
S6-CO	278.73 ± 9.89	220 ÷ 375

Fig. 6 represents sensors' response to the alternating presence of synthetic air and toxic gases. Calibration of the sensor is necessary to find a correlation between the concentration level and sensor output. The calculated sensitivities from Table 3 allowed the current responses of sensors to toxic gas concentration levels to be converted, which is illustrated in Fig. 7. The obtained curves show cross-sensitivity of sensors to the presence of NO₂ or SO₂.

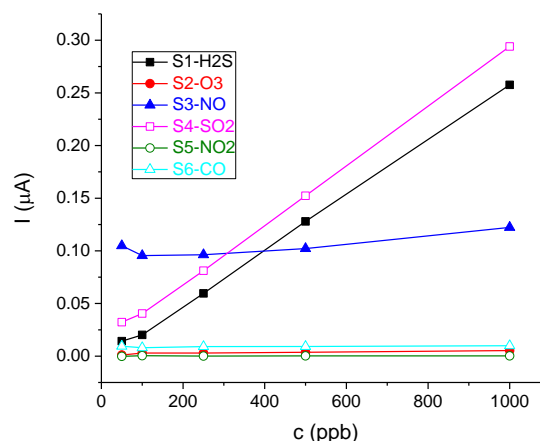

Fig. 4. Sensors responses in given concentrations of SO₂.

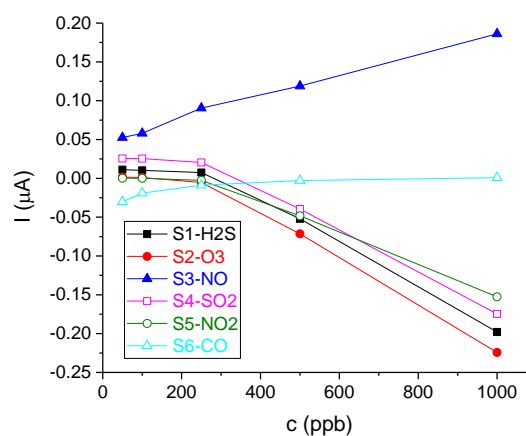

Fig. 5. Sensors responses in given concentrations of NO₂.

Table 4

Sensors' responses to SO₂ only NO₂ alone and to mixture of them.

Sensor model	Response to 1 ppm of SO ₂ [ppm]	Response to 1 ppm of NO ₂ [ppm]	Response to 1 ppm of SO ₂ and 1 ppm of NO ₂ [ppm]	Calculated response to 1 ppm of SO ₂ and 1 ppm of NO ₂ [ppm]
S1-H ₂ S	0.15	-0.16	-0.01	-0.01
S2-O ₃	0.00	0.70	0.76	0.70
S3-NO	0.04	0.23	0.27	0.27
S4-SO ₂	0.91	-0.75	0.11	0.16
S5-NO ₂	0.00	0.92	1.03	0.92
S6-CO	0.00	0.01	0.01	0.01

It can be observed that sensors reacted slower to NO_2 than to SO_2 . Every sensor except for the S6-CO reacted to the toxic gases used in the experiment. The difference between S2-O₃, S4-SO₂ and S5-NO₂ responses to SO_2 and NO_2 gas should be equal to the response of the sensors to a mixture of these gases with identical concentrations, but it is not equivalent, as it is presented in Table 4.

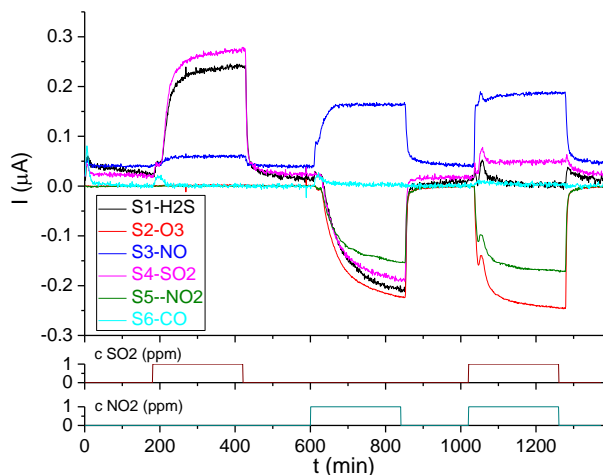

Fig. 6. Raw sensor responses to SO_2 and NO_2 .

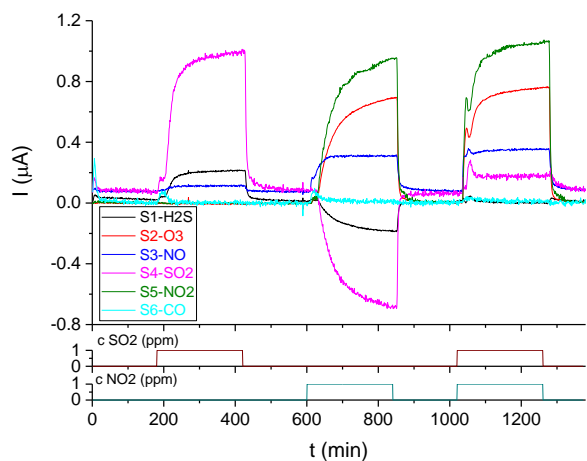

Fig. 7. Sensors' responses converted to concentrations.

5. Discussion

In section 4, it was shown that the sensors also react to non-target gases. For example, the sensors' responses to a mixture of 1 ppm of SO_2 and 1 ppm of NO_2 is not equal to the sum of responses to such concentrations of these gases separately. Usually the sensors are calibrated in individual gases only. It can be assumed that this approach does not guarantee an accurate estimation of concentrations. This approach does not take into account the different interactions between gases and sensors. Therefore, it can

be assumed that much better results can be obtained by calibration also in mixtures, which will be demonstrated later.

Table 5
MLR regression summary done from single gas measurement data.

Parameter	SO_2		NO_2	
	Value	Standard Error	Value	Standard Error
β_0	0.01	0.00	-0.01	0.00
β_1	0.79	0.15	-0.43	0.24
β_2	-1.43	0.46	-17.54	0.75
β_3	-0.16	0.02	-0.74	0.03
β_4	3.22	0.13	0.53	0.22
β_5	-3.59	0.66	18.22	1.08
β_6	-0.16	0.08	0.17	0.12

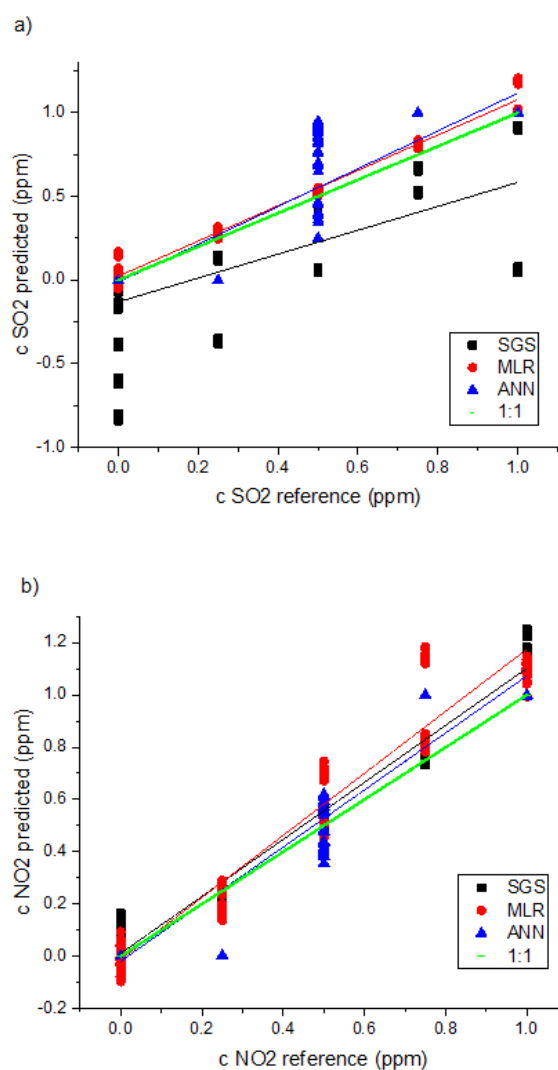

Fig. 8. Predictions of gas concentrations made on a test dataset with the use of SGS, MLR and ANN methods against reference concentrations of: a) SO_2 , b) NO_2 with linear regression lines. The training set consisted of only measurements in one toxic gas and synthetic air.

Two analyses were made to verify this assumption. The first was obtained by teaching algorithms on learning data only consisting of sensor responses to individual gases. In the second case, responses to single gas as well as mixtures were used as training data. All algorithms were tested on data, measured later than the calibration data, but using identical measuring sequences.

5.1. Calibration in single gas. In this analysis, the training dataset consisted of a part of total training set: 180 points measured in synthetic air alternately with 1 ppm of one toxic gas. The total test dataset was used for testing the models. To determine the parameters of Multiple Linear Regression, (2) was used on training dataset, where independent variables $x_{1...6}$ were the responses of the sensors in the following order: S1-H2S, S2-O3, S3-NO, S4-SO2, S5-NO2, S6-CO.

The extracted parameters are included in Table 5. The higher value of the parameter, the more important is the sensor response by which it is multiplied. In the case of the prediction of the SO₂ concentration, response of the SO₂ and NO₂ sensors is the most significant. Similarly, O₃ and NO₂ sensors provide the most information about the NO₂ concentration.

Fig. 8 shows scatterplots of the predicted versus reference concentrations using SGS, MLR and ANN algorithms on the test dataset. Dispersion of points at all concentrations is similar for all methods except for ANN. For ANN (blue triangles), in the case of both gases, the measurements for 0.25 ppm, and 0.75 ppm were identified as clearly underestimated and overstated concentrations, respectively. This might be the consequence of an overfitting caused by the relatively small training dataset. The ANN was trained on only 0 ppm and 1 ppm of toxic gas, so it tried to match the sensor responses with values that were known to this network. The network had difficulty correctly identifying the intermediate value.

Linear regression lines between reference values and model outputs show how close the model is to making perfect predictions. The slope of the ideal model should be equal to 1 (green line). The obtained values of the slopes for all methods are presented in Table 6.

Table 6

Slopes and their uncertainties of linear regression lines drawn between predicted and reference data after calibration in single gas.

Method	SO ₂ Slope ± u	NO ₂ Slope ± u
SGS	0.71 ± 0.04	1.09 ± 0.01
MLR	1.06 ± 0.00	1.19 ± 0.01
ANN	1.13 ± 0.01	1.09 ± 0.01

Table 7 gives performance metrics for SGS, MLR and ANN methods. It has been proven that the SGS method is not accurate enough for calculating concentration of

sulphur dioxide, because the S4-SO₂ sensor reacts to other gas types, such as nitrogen dioxide (as shown in Table 4) and hence generates false signals. The use of the MLR and ANN methods achieves more precise results and their slope values are closer to 1. On the other hand, SGS is the best method for the determination of NO₂.

Table 7

Statistics of error calculated to assess the performance of gas prediction methods with respect to the input dataset while algorithms were trained on single gas measurement data.

Gas	Method	R2	RMSE [ppm]	MAE [ppm]
SO ₂	SGS	0.017	0.339	0.197
	MLR	0.971	0.057	0.036
	ANN	0.844	0.132	0.064
NO ₂	SGS	0.951	0.074	0.038
	MLR	0.906	0.103	0.059
	ANN	0.903	0.105	0.048

5.2. Calibration in single gas and binary mixture. The calibration procedure was analogous to that presented in Section 5.1. The only difference was the use of training dataset enlarged by measurements made in binary mixtures. The test dataset has not been changed.

The extracted parameters of Multiple Linear Regression given by (2) are included in Table 8. They changed a bit compared to the previous calibration (Table 5). In the SO₂ calculation, the S2-O3 sensor weight parameter increased significantly. This is the effect of calibration in a mixture, where nitrogen dioxide, was present at the same time.

Scatterplots of the predicted versus reference concentrations using SGS, MLR and ANN algorithms are shown in Fig. 9. The dispersion of points at all concentrations is narrower than in the approach from Section 5.2 (Fig. 6). For SO₂, the regression for MLR and ANN lines overlap with the line predicted = reference (1:1), which means that these models except make perfect predictions. The obtained values of the slopes of regression lines for all methods are presented in Table 9.

Table 8

MLR regression summary done from single gas and binary mixture measurement data.

Parameter	SO ₂		NO ₂	
	Value	Standard Error	Value	Standard Error
β_0	0.01	0.00	-0.01	0.00
β_1	-0.33	0.13	0.74	0.32
β_2	-5.44	0.31	-12.09	0.78
β_3	-0.21	0.02	-0.70	0.04
β_4	4.28	0.12	-0.48	0.29
β_5	2.71	0.42	10.33	1.05
β_6	-0.42	0.07	0.67	0.17

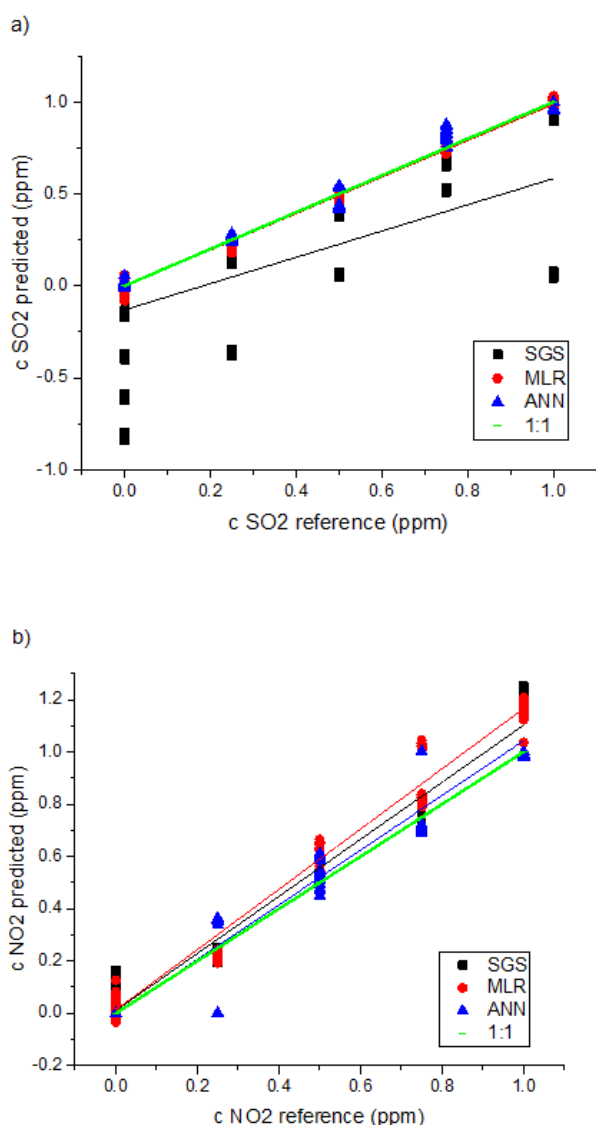

Fig.9. Predictions of gas concentrations made on test dataset with the use of SGS, MLR and ANN methods against reference concentrations of: a) SO₂, b) NO₂ with linear regression lines. The training set consisted of measurements in single gas, binary mixture and synthetic air.

Table 9

Slopes and their uncertainties of linear regression lines drawn between predicted and reference data after calibration in single gas and binary mixture.

Method	SO ₂ Slope ± u	NO ₂ Slope ± u
SGS	0.71 ± 0.04	1.09 ± 0.01
MLR	0.99 ± 0.00	1.15 ± 0.01
ANN	1.00 ± 0.00	1.09 ± 0.01

The performance summary for the SGS, MLR and ANN models is shown in Table 10. Both the MLR and ANN gave similar predictions, but for NO₂, the ANN

slightly outperformed the MLR. Additional training data containing measurements in two toxic gases at once improved the results. This means that information about interfering gases is important and should be included in calibration processes.

The SGS algorithm showed the best results in NO₂ predictions. This may be related to the presence of an advanced filter in the S5-NO₂ sensor. Such filter removes interfering gases, resulting in better selectivity. It chemically adsorbs some gas types and therefore has a limited lifetime, which is different from the gas cell lifetime. After this time, the sensor may show incorrect readings and it should be calibrated.

Table 10

Statistics of error calculated to assess the performance of gas prediction methods with respect to the input dataset while algorithms were trained on single gas and binary mixture measurement data.

Gas	Method	R ²	RMSE [ppm]	MAE [ppm]
SO ₂	SGS	0.017	0.339	0.197
	MLR	0.995	0.023	0.017
	ANN	0.994	0.026	0.043
NO ₂	SGS	0.951	0.074	0.038
	MLR	0.937	0.084	0.054
	ANN	0.944	0.079	0.034

6. Conclusions

In the present investigation, six electrochemical gas sensors were used in order to reveal their cross-sensitivities. Two different types of gases - SO₂ and NO₂ - were applied at a concentration of 1 ppm. Mixtures with different balances of these two gases were also taken into consideration. The results presented in the text confirm that electrochemical sensors do not only react to the presence of the gases they are constructed to detect. For each sensor, the current response usually depends on the presence of several gases. The least selective were the S1-H₂S and S3-NO sensors, both responding to SO₂ and NO₂.

When using the SGS method, the sensor responses in multicomponent gas mixtures showed that a concentration of 1 ppm of SO₂ and 1 ppm of NO₂ was misclassified as a mixture of 0.01 ppm H₂S, 0.70 ppm O₃, 0.27 ppm NO, 0.16 ppm SO₂, 0.92 ppm NO₂ and 0.01 ppm CO. The results proved that analyses performed with amperometric sensors can be error prone in the presence of interfering gases.

Cross-sensitivity caused by interfering gases is a very important parameter. It can mislead the user of the sensor that there is target gas present, or it may reduce the reported level of the target gas when in fact this is not true and the user does not know that they may be at risk. In order to improve the reliability of target gas measurements, further treatment of the data is required.



This can be carried out by application of machine learning algorithms, such as MLR and ANN.

It was shown that calibration in mixtures provides better results than in single gases, because it takes into account information about how the sensor responds to interfering gases. This was presented in two calibration approaches with the use of the SGS, MLR and ANN algorithms. In the first, the algorithms were trained on data consisting of measurements only in a single gas or synthetic air. The second contained additional measurements in two gases at once.

The R^2 coefficient and RMSE and MAE error statistics were used to evaluate which model was the best. In SO_2 predictions, Multiple Linear Regression and Artificial Neural Networks resulted in a much higher R^2 and lower RMSE and MAE than SGS, evidencing that the MLR and ANN are more effective methods. The case was different in NO_2 calculations, because the SGS was found to be the best algorithm. This may be related to the presence of an advanced filter inside the S5- NO_2 sensor.

Acknowledgements. This work has been partially supported by the Statutory Funds of Electronics, Telecommunications and Informatics Faculty, Gdansk University of Technology and by the project POIR.01.01.01-0907/16 conducted by PM Ecology sp. z o. o. and supported by the National Centre for Research and Development, Operational Programme Smart Growth (PO IR).

REFERENCES

- [1] Air quality in Europe – 2019 report, European Environment Agency, No 10/2019, ISSN 1977-8449, Denmark, 2019.
- [2] N. Barsan, D. Koziej, and U. Weimar, "Metal oxide-based gas sensor research: How to?", *Sens. Actuators B: Chem.*, vol. 121, pp. 18-35, 2007.
- [3] A. Dey, "Semiconductor metal oxide gas sensors: A review", *Mater. Sci. Eng. B.*, vol. 229, pp. 206-217, 2018.
- [4] Z. Lei, T. Feng-Chun, P. Xiong-Wei, and Y. Xin, "A rapid discreteness correction scheme for reproducibility enhancement among a batch of MOS gas sensors", *Sens. Actuators A: Phys.*, vol. 205, pp. 170-176, 2014.
- [5] Y. Xu, X. Zhao, Y. Chen, and W. Zhao, "Research on a Mixed Gas Recognition and Concentration Detection Algorithm Based on a Metal Oxide Semiconductor Olfactory System Sensor Array", *Sensors*, vol. 18 (10), 2018.
- [6] J. E. Haugen, and K. Kvaal, "Electronic nose and artificial neural network", *Meat Sci.*, vol. 49, pp. S273-S286, 1998.
- [7] S. Omatu, and M. Yano, "E-nose system by using neural networks", *Neurocomputing*, vol. 172, pp. 394-398, 2016.
- [8] M.N. Abbas, G.A. Moustafa, and W. Gopel, "Multicomponent data analysis of some environmentally important gases using semiconductor tin oxide sensors", *Anal. Chim. Acta*, vol. 431, pp. 181-194, 2001.
- [9] T. Pustelny, M. Procek, E. Maciak, A. Stolarczyk, S. Drewniak, M. Urbańczyk, M. Setkiewicz, K. Gut and Z. Opilski, "Gas sensor based on nanostructures of semiconductors ZnO and TiO_2 ", *Bull. Pol. Ac.: Tech.*, vol. 60 (4), pp. 853-859, 2012.
- [10] T. Pustelny, M. Setkiewicz, S. Drewniak, E. Maciak, A. Stolarczyk, M. Urbańczyk, M. Procek, K. Gut, Z. Opilski, I. Pasternak, and W. Strupinski, "The sensibility of resistance sensor structures with graphene to the action of selected gaseous media", *Bull. Pol. Ac.: Tech.*, vol. 61 (2), pp. 293-300, 2013.
- [11] C. Melios, V. Panchal, K. Edmonds, A. Lartsev, R. Yakimova, and O. Kazakova, "Detection of Ultralow Concentration NO_2 in Complex Environment Using Epitaxial Graphene Sensors", *ACS Sens.*, vol. 3 (9), pp. 1666-1674, 2018.
- [12] F. Schedin, A. K. Geim, S. V. Morozov, E. W. Hill, P. Blake, M. I. Katsnelson, and K. S. Novoselov, "Detection of Individual Gas Molecules Adsorbed on Graphene", *Nat. Mater.*, vol. 6 (9), 652-655, 2007.
- [13] M. Blagojevic, M. Papic, M. Vujcic, and M. Sucurovic, "Artificial neural network model for predicting air pollution. Case study of the Moravia district, Serbia", *Environ. Prot. Eng.*, vol. 44, nr 1, pp. 129-139, 2018.
- [14] H. Sundgren, F. Winquist, I. Lukkari, and I. Lundstrom, "Artificial neural networks and gas sensor arrays: quantification of individual components in a gas mixture", *Meas. Sci. Technol.*, vol. 2, pp. 464-469, 1991.
- [15] A. Loutfi, S. Coradeschi, G. K. Mani, P. Shankar, and J. B. B. Rayappan, "Electronic noses for food quality: A review", *J. Food Eng.*, vol. 144, pp. 103-111, 2015.
- [16] J. S. Do, and P. J. Chen, "Amperometric sensor array for NO_x , CO , O_2 and SO_2 detection", *Sens. Actuators B: Chem.*, vol. 122, pp. 165-173, 2007.
- [17] S. Osowski, K. Brudzewski, L. Tran Hoai, "Modified neuro-fuzzy TSK network and its application in electronic nose", *Bull. Pol. Ac.: Tech.*, vol. 61 (3), pp. 675-680, 2013.
- [18] R. Baron, John Saffell, "Amperometric Gas Sensors as a Low Cost Emerging Technology Platform for Air Quality Monitoring Applications: A Review", *ACS Sens.*, vol. 2 (11), pp. 1553-1566, 2017.
- [19] M. M. Rahman, C. Charoenlarnpopparut, P. Suksompong, P. Toochinda, and A. Taparuggsanagorn, "A False Alarm Reduction Method for a Gas Sensor Based Electronic Nose", *Sensors*, vol. 17 (9), 2017.
- [20] M. Hossain, J. Saffell, and R. Baron, "Differentiating NO_2 and O_3 at Low Cost Air Quality Amperometric Gas Sensors", *ACS Sens.*, vol. 1 (11), pp. 1291-1294, 2016.
- [21] G. Jasinski, A. Strzelczyk, and P. Kosciński, "Low cost electrochemical sensor module for measurement of gas concentration", *IOP Conf. Ser.: Mater. Sci. Eng.*, vol. 104, 012034, 2015.
- [22] G. Jasinski, P. Kalinowski, L. Wozniak, and P. Jasinski, "An electronic nose based on the semiconducting and electrochemical gas sensors", *2017 21st European Microelectronics and Packaging Conference (EMPC) & Exhibition*, Warsaw, Poland, pp. 1-4, 2017.