

MEASUREMENTS OF RELATIVE FREQUENCY INSTABILITY

Dariusz ŚWISULSKI

Gdansk University of Technology, Faculty of Electrical and Control Engineering
 phone.: 58 3471397 e-mail: dariusz.swisulski@pg.gda.pl

Summary: Frequency constancy can be determined by the change in time for the subsequent periods. The article shows that classical the method of digital period measurement is not suitable for the measurement process. Therefore, a method using an integrating circuit is being proposed. Errors in the measurement of the given method have been analyzed.

Keywords: frequency measurements, measurement period, the frequency inconstancy.

1. INTRODUCTION

In modern metrology, frequency it is one of the most frequently measured parameters characterizing the physical processes. Currently, frequency measurements are dominated by digital methods. They rely mostly on direct measurement of the frequency based on the definition - by counting the number of periods per time unit, or indirect measurement by measuring the time duration of one period or an integer of multiplication of periods. In the second case, we can specify a frequency stability in a simple manner by comparing consecutive results. The accuracy of such comparison will depend on the frequency of the reference signal generator, which periods are counts during a single period of the measured signal.

When such obtained accuracy is not satisfactory you can use other methods. The article presents the author's proposed method using integrating systems, which is a combination of analog methods and digital methods.

2. COMPARISON OF ADJECENT TIME PERIODS

Absolute frequency instability $\Delta f(t)$ can be described by the dependency (1):

$$\Delta f(t) = f(t) - f_0 \quad (1)$$

where:

f_0 – frequency at the initial measurement time,

$f(t)$ – frequency at time t .

The relative instability of frequency is related to the frequency f_0 :

$$\delta f(t) = \frac{\Delta f(t)}{f_0} \quad (2)$$

If we assume, that the frequency measurement is performer by measuring the time for the subsequent period T_i , then the relative instability of the frequency during the period T_i may be expressed as:

$$\delta f_i = \frac{f_i - f_0}{f_0} \quad (3)$$

In a situation, where because of its changes, the frequency at subsequent times of measurement differs from the initial value f_0 , a better information about the instability can be obtained by comparing the current frequency with the value in the previous period f_{i-1} :

$$\delta f_i = \frac{f_i - f_{i-1}}{f_{i-1}} \quad (4)$$

After substitution of the dependency $f_{i-1} = 1/T_{i-1}$ and $f_i = 1/T_i$ one obtains:

$$\delta f_i = \frac{T_{i-1} - T_i}{T_i} \quad (5)$$

If the time period T_i is determined by counting the periods N_i of the reference signal generator with a frequency f_g ($T_i = N_i/f_g$), then the relative frequency instability can be calculated from the number of periods of the reference signal generator counted in subsequent periods of the measured signal:

$$\delta f_i = \frac{N_{i-1} - N_i}{N_i} \quad (6)$$

The determination of the frequencies based on the length of a single period is burdened with static and dynamic errors. The static error includes the quantization error (if a single period T_i is not an integer of multiple of periods of the reference signal generator), frequency error of reference generator [1] and a triggering error (resulting from the uneven delay of the time of opening and closing the gate counter [2]). Dynamic errors arise from the changes of the measured frequency of the time period T_i [2].

The quantization error is due to an error of not synchronizing at the beginning and end of the measurement time interval. The maximum quantization error value is

equal to one time period being counted from the reference generator.

If one assumes, that as a result of the quantization error, one extra period will be counted $N_{i-1}^* = N_{i-1} + 1$, then instead of the correct value of relative instability δf_i one will get an incorrect δf_i^* value. The relative error of measurement of the relative instability can be calculated with the following equation:

$$\delta_{\delta i} = \frac{\delta f_i^* - \delta f_i}{\delta f_i} = \frac{\frac{(N_{i-1} + 1) - N_i}{N_i} - \frac{N_{i-1} - N_i}{N_i}}{\frac{N_{i-1} - N_i}{N_i}} \quad (7)$$

and after the transformation one obtains:

$$\delta_{\delta i} = \frac{1}{N_{i-1} - N_i} \quad (8)$$

If one assumes, that as a result of the quantization error, one extra period will be counted $N_i^* = N_i + 1$, then instead of the correct value of relative instability δf_i one will get an erroneous δf_i^* value. The relative measurement error of the relative instability $\delta_{\delta i}$ can be calculated from the following equation:

$$\delta_{\delta i} = \frac{\frac{N_{i-1} - (N_i + 1)}{N_i} - \frac{N_{i-1} - N_i}{N_i}}{\frac{N_{i-1} - N_i}{N_i}} \quad (9)$$

after transformation:

$$\delta_{\delta i} = -\frac{1}{(N_{i-1} - N_i) \left(1 + \frac{1}{N_{i-1}}\right)} \quad (10)$$

If one considers the most unfavorable case, where at the same time, one period of more than $N_{i-1}^* = N_{i-1} + 1$ and one period of less $N_i^* = N_i + 1$ is counted:

$$\delta_{\delta i} = \frac{\frac{(N_{i-1} + 1) - (N_i - 1)}{N_i} - \frac{N_{i-1} - N_i}{N_i}}{\frac{N_{i-1} - N_i}{N_i}} \quad (11)$$

and after transformation:

$$\delta_{\delta i} = -\frac{1}{(N_{i-1} - N_i) \left(\frac{N_i - 1}{N_{i-1} + N_i}\right)} \quad (12)$$

Figure 1 shows the error of relative instability measurement $\delta_{\delta i} = f(N_i)$ given by formulas (8), (10) and (12) for $N_{i-1} = 10000$.

As is apparent from the graph, the method has a very large number of relative errors in the case where $N_i \approx N_{i-1}$. With high frequency stability, such a situation occurs quite often. Therefore, a method based on the measurement period is not suitable for measuring the instability of the relative

frequencies. It is necessary to develop other methods – a proposal for such a method is presented later in this article.

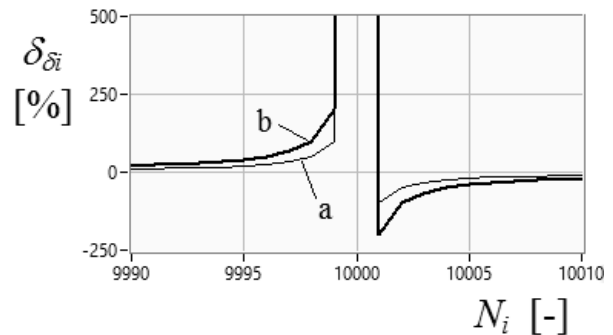

Fig. 1. Error of relative instability measurement $\delta_{\delta i} = f(N_i)$ for $N_{i-1} = 10000$; a – given by formula (8) and (10), b – given by formula (12)

3. MEASUREMENT BY INTEGRAL METHOD

Since, as it was shown, the measurement of the relative frequency of the instability of the measuring time for the subsequent period is characterized by significant errors, a method combining a digital and analog measurement has been developed for this purpose.

In order to implement this method, a special transducer of relative difference values for two successive periods of T_{i-1} and T_i , has been designed with the use of an integrating circuit. Voltage waveforms in this system are shown on Figure 2.

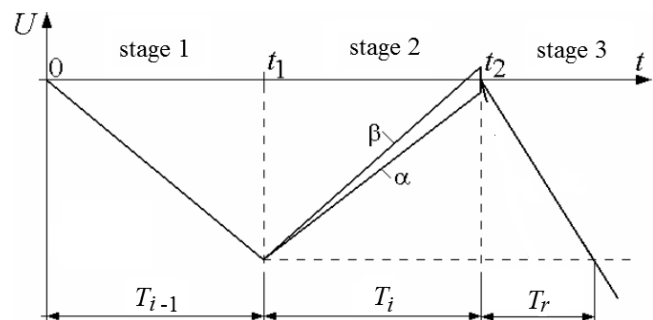

Fig. 2. Voltage waveforms in the integral system

The measurement is carried out in three stages. The first stage begins at the start of the first of the compared periods T_{i-1} . At $t = 0$ to the input of the integrator, reference voltage U_{ref} is fed. The output voltage of the integrator decreases linearly during the period T_{i-1} reaching the level of:

$$U(t_1) = -\frac{1}{RC} \int_0^{t_1} U_{ref} dt = -\frac{1}{RC} \cdot U_{ref} \cdot T_{i-1} \quad (13)$$

At the end of the period T_{i-1} the first step of measuring ends, in the first sampling/storing arrangement the voltage $U_i = U(t_1)$ is stored and the second stage begins. At the beginning of this stage, the control system disconnects the input voltage U_{ref} from the integrator and connects the same voltage, but of opposite polarity ($-U_{ref}$). In this stage, during the second period of the measured signal T_i , the voltage at the output of the integrator increases linearly, reaching the t_2 time value:

$$U(t_2) = U(t_1) - \frac{1}{RC} \int_{t_1}^{t_2} -U_{ref} dt = -\frac{1}{RC} \cdot U_{ref} \cdot (T_{i-1} - T_i) \quad (14)$$

If the $T_{i-1} > T_i$, then the voltage $U(t_2) < 0$ (straight line α on Figure 2), and when $T_{i-1} < T_i$, then the voltage $U(t_2) > 0$ (straight line β on Figure 2).

The output of the integrator is connected to the input of an amplifier with a gain of $-A$ (fig. 3). The output of the amplifier is connected to the two half rectifier, the output of which is obtained absolute value from the amplified A times the output voltage of the integrator. At the end of the period T_i ends the second stage and in the second sampling circuit, the voltage output of the two half amplifier value is stored:

$$U_{II} = \frac{A}{RC} U_{ref} \cdot |T_{i-1} - T_i| \quad (15)$$

The third stage starts with the zeroing of the output of the integrator. At the same time, the output of the integrator is connected to a first input of a compactor, to whose other input voltage is connected represented by formula (13), stored in the first sampling/storing system. U_{II} is supplied on the integrator input which is stored in the second sampling/storing system. As a result, the output voltage of the integrator falls linearly. After a period of T_r , the voltage reaches the value U_j :

$$U(t_2 + T_r) = -\frac{1}{RC} \cdot \int_{t_2}^{t_2 + T_r} U_{II} dt = U_j \quad (16)$$

After substituting in place of the voltage $U_{II} = U(t_2)$ from the equation (15) and in the place of $U_j = U(t_1)$ according to (13) and linear transformations we obtain:

$$T_r = \frac{T_{i-1}}{|T_{i-1} - T_i|} \cdot \frac{RC}{A} \quad (17)$$

After assuming the $T_{i-1} \approx T_i$ from the equation (5) we get:

$$T_r = \frac{1}{|\delta f_i|} \cdot \frac{RC}{A} \quad (18)$$

And hence after conversion, we can calculate the relative frequency instability:

$$|\delta f_i| = \frac{RC}{A} \cdot \frac{1}{T_r} \quad (19)$$

From equation (18) one can see, that the time T_r , after which the voltage is the output of the integrator is inversely proportional to the relative frequency instability. By measuring the time from the equation (19) one can determine δf_i .

One should note, that for small values of δf_i value T_r assumes large values, which results in long measurement time. This time can be reduced by reducing the value of the RC value or increasing the value of A . The ratio RC/A can be selected in such a way that the predetermined minimum value $|\delta f_i|_{\min}$ can get the maximum established time $T_{r\max}$:

$$\frac{RC}{A} = |\delta f_i|_{\min} \cdot T_{r\max} \quad (20)$$

Figure 3 shows a block diagram of the comparator of two consecutive periods.

The task of the US control system is to generate digital signals controlling the measurement circuits. The voltage source of reference U supplies two voltages U_{ref} and $-U_{ref}$ attached to the input of an integrator in the first and second stages of integration. For generating adequate accuracy, it is important to ensure equal absolute values of these voltages, but their level does not affect the results.

The analog multiplexer M in the corresponding stages of integration switches on to the input of the integrator the reference voltage U_{ref} and $-U_{ref}$ or voltage from the output of the sampling/storing system $SH2$. The task of the integrator and the integrator I is the integration of input values. An amplifier A amplifies the output voltage of the integrator on completion of the stage 2 of the measurement. A two half rectifier R allows to obtain the amplified absolute value voltage of the end of the second stage of integration.

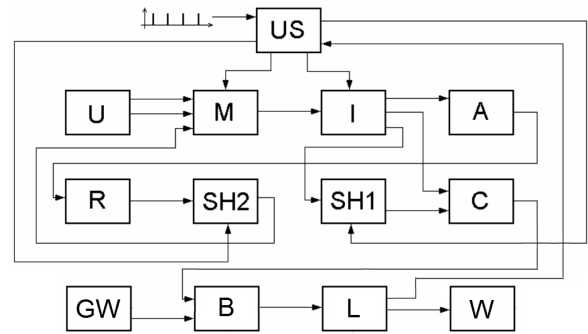

Fig. 3. A block diagram of the comparator duration of two consecutive periods: US – control system, U - reference voltage source, M – analog multiplexer, I - integrator, A - amplifier, R - rectifier, SH1, SH2 – sampling/storing system, C - comparator, GW – reference generator, B - gate, L - counter, W - indicator

The purpose of the sampling/storing system $SH1$ is to download and store the output voltage of the integrator at the end of stage 1, while the task of $SH2$ is to download and store the amplified and rectified output voltage of the integrator at the end of the second stage. The comparator C compares the output voltage of the integrator in the third stage of integration with the voltage memorized in the sampling circuit $SH1$. The voltage at the output of the comparator depends on which of the two input voltages is larger.

The output voltage of the compactor C is connected to the circuit gating B impulses from the reference generator GW . From the number of pulses counted in the counter L depends the indication in the indicator W . Information about the result of the measurement is also fed to the control system, through which it can be used in a measurement system.

If a measurement is required at a higher frequency, one can use a larger number of inspection systems with offset measurements as a function of time.

4. ACCURACY OF INTEGRATION METHOD

The source of measurement errors include among other, integrator elements. RC integrator component values may differ from the ones adopted. When one assumes, that the

measurement time is short enough that the values of these elements do not change during the measurement and are as follows: $R(1+\delta_R)$ and $C(1+\delta_C)$. A result of errors δ_R and δ_C values of these elements, the relation (19) takes the form:

$$|\delta_i| = \frac{R(1+\delta_R) \cdot C(1+\delta_C)}{A} \cdot \frac{1}{T_r} \quad (21)$$

Hence the relative measurement error due to error values of R and C is:

$$\delta_{\delta RC} = \frac{\frac{R(1+\delta_R) \cdot C(1+\delta_C)}{A} \cdot \frac{1}{T_r} - \frac{RC}{A} \cdot \frac{1}{T_r}}{\frac{RC}{A} \cdot \frac{1}{T_r}} \quad (22)$$

which, assuming $\delta_R + \delta_C \gg \delta_R \cdot \delta_C$ gives:

$$\delta_{\delta RC} \approx \delta_R + \delta_C \quad (23)$$

Another source of errors may be an incorrect amplification value A . If the amplification does not change during the measurement and is $A(1+\delta_A)$, due to error δ_A the dependence (19) takes the form:

$$|\delta_i| = \frac{RC}{A(1+\delta_A)} \cdot \frac{1}{T_r} \quad (24)$$

Hence the relative measurement error caused by an error of A is:

$$\delta_{\delta A} = \frac{\frac{RC}{A(1+\delta_A)} \cdot \frac{1}{T_r} - \frac{RC}{A} \cdot \frac{1}{T_r}}{\frac{RC}{A} \cdot \frac{1}{T_r}} \quad (25)$$

which, assuming $\delta_A \ll 1$ gives:

$$\delta_{\delta A} \approx -\delta_A \quad (26)$$

Measurement accuracy is also affected by unequal absolute values of the voltages U_{ref} and $-U_{ref}$. As a result of the error of the reference voltage source, the absolute values of voltages in the first and second stages of integration may be different.

POMIARY WZGLĘDNEJ NIESTAŁOŚCI CZĘSTOTLIWOŚCI

Stołość częstotliwości można wyznaczyć jako względną zmianę częstotliwości w czasie pomiaru. Pomiar stołości częstotliwości przez pomiar czasu trwania sąsiednich okresów sygnału charakteryzuje się dużymi błędami. Dlatego zaproponowano metodę wykorzystującą układy całkujące. Całkowanie odbywa się w trzech etapach, przy czym dwa pierwsze etapy odbywają się w czasie dwóch sąsiednich okresów analizowanego sygnału, czas trwania trzeciego etapu jest odwrotnie proporcjonalny do względnej niestałości częstotliwości. Jeżeli wymagany jest pomiar ciągły, można zastosować większą liczbę układów pomiarowych z przesuniętymi pomiarami w funkcji czasu. W artykule przedstawiono analizę błędów występujących przy pomiarze opisaną metodą - omówiono błędy wynikające ze zmienionej wartości RC , wzmocnienia A , napięć wzorcowych oraz błędów kwantowania.

Słowa kluczowe: pomiary częstotliwości, pomiar okresu, niestałość częstotliwości.

Of course, one should remember about the time measurement error of T_r . If this time is measured by counting the periods of the reference signal generator ($T_r = N_r/f_g$), then the quantization, reference frequency generator and trigger errors occur.

The measurement error resulting from the quantization error can be calculated as:

$$\delta_{\delta N} = \frac{\frac{RC}{A} \cdot \frac{1}{N_r+1} - \frac{RC}{A} \cdot \frac{1}{N_r}}{\frac{RC}{A} \cdot \frac{1}{N_r}} \cdot \frac{f_g}{f_g} \quad (27)$$

and after transformations:

$$\delta_{\delta N} = -\frac{1}{N_r+1} \quad (28)$$

For $N_r \gg 1$ the relative measurement error is equal to the inverse of the number of counted periods. Therefore, according to equation (20) one should adjust RC and A , that the time T_r is not too short.

5. SUMMARY CONCLUSIONS

The method of measuring the relative instability of frequency presented in the article, despite its simplicity, is characterized by satisfactory metrological characteristics. The performer analysis of accuracy showed that errors resulting from imperfections used to carry out the measurement system elements are not significant, and the total error is incomparably smaller than with the classical method of digital measurement period.

6. BIBLIOGRAPHY

1. Pawłowski E.: Porównywanie częstotliwości wzorcowych w środowisku LabVIEW, Zeszyty Naukowe Wydziału Elektrotechniki i Automatyki Politechniki Gdańskiej, Nr 34/2013, str. 53-56.
2. Świsulski D.: Cyfrowa rejestracja sygnałów impulsowych z częstotliwościowym nośnikiem informacji. Wydawnictwo Politechniki Gdańskiej, Gdańsk 2006.