

Methodology of experimental research on efficiency of hydro-mechanical automatic gearbox

Piotr Patrosz^[0000-0002-8711-7062], Marcin Bąk^[0000-0002-1283-9933],
Paweł Załuski^[0000-0003-1332-3661], Paweł Śliwiński^[0000-0003-1332-3661]
and Mykola Karpenko^[0000-0002-1915-5219]

¹ Gdansk University of Technology, Gdansk, Poland, piotr.patrosz@pg.edu.pl

² Gdansk University of Technology, Gdansk, Poland, marcin.bak@pg.edu.pl

³ Gdansk University of Technology, Gdansk, Poland, pawel.zaluski@pg.edu.pl

⁴ Gdansk University of Technology, Gdansk, Poland, pawel.sliwinski@pg.edu.pl

⁵ Vilnius Gediminas Technical University, Vilnius, Lithuania, mykola.karpenko@vgtu.lt

Abstract. The article shortly describes the design and principle of operation of the hydromechanical gearbox and presents the methodology and design of test stands used for testing hydro-mechanical prototype gearbox developed at Technical University of Gdansk. The article presents an approach according to which, in order to obtain reliable measurement data, it is necessary to separate the tests of the hydraulic and mechanical parts of the gearbox. For this reason, the tests of the pump and the hydraulic motor are also presented. To validate this approach sample test results are included and discussed.

Keywords: Gearbox, Hydraulics, Efficiency

1 Introduction

The gearboxes of slow-moving vehicles are one of the most intensively developed components of these machines. The growing use of working machines such as telescopic loaders or rough terrain forklifts in construction and agricultural works, results in works aimed at improving their design, operator's comfort and achieving higher efficiency, which leads to lower fuel consumption. For many years, the driving systems of these machines included mechanical, hydraulic and CVT transmissions. Hydraulic transmission allows low driving speeds and a stepless change of gear ratio[1–3]. Thanks to this, an operator has the opportunity to adjust the optimal speed of movement to the work performed. On the other hand, the mechanical transmission provides higher efficiency, without requiring expensive components of the hydraulic system such as pumps and motors. The disadvantage of these gears is the precisely defined value of the gear ratio between the mating gears resulting from the number of teeth of these gears. CVT transmissions combine the best of both worlds, but are very expensive at the same time. As part of the LIDER project at the Gdansk University of Technology, a design of a hybrid gearbox was developed that combines the advantages of both a hydraulic and a mechanical gearbox, while maintaining a relatively simple design, compared to CVT.

Comprehensive research has to be conducted to determine the efficiency at every point in the gearbox operation. The obtained characteristics will make it possible to determine the influence of the torque and the rotational speed on the efficiency. In order

to create the discussed characteristics, a methodology for carrying out tests on a test stand that uses a hydraulic system as a load generator was developed. The test stand of the Hydraulics and Pneumatics Team of the Gdansk University of Technology was adapted to carry out tests of the mechanical transmission in the full range of its target operating parameters, in accordance with the developed procedure.

2 Design and principle of operation

As mentioned earlier, the tested gearbox is a hybrid of a hydraulic and mechanical transmission, which work interchangeably. Low gear ratios are realized with the use of a mechanical transmission, high gears with the use of a hydraulic and mechanical transmission. The kinematic diagram and a photo of the gearbox is shown in figure 1. The transmission consists of eight gears, a main hydraulic variable displacement pump with and a charge pump on the same shaft, a hydraulic double-motor and three wet clutches. Two clutches are necessary for gear shifting and disengagement of the mechanical transmission while using hydraulic transmission. The third clutch is only an auxiliary element used during the preliminary tests. The hydraulic motor used could work in the so-called freewheeling conditions. It means, it allowed the shaft to rotate freely without supplying the motor with hydraulic fluid.



Fig. 1. Kinematic scheme and photo of hydromechanical gearbox

The gearbox shown above allows you to choose one of the four forward gears and one reverse. The selected ratio results from: engagement of relevant clutches and setting of hydraulic machines (main pump and hydraulic motor) displacement. Table 1 shows the gearbox component configurations and settings for each gear.

The drive from the engine is transferred to the main shaft of the gearbox. In gears I and II, the drive is transmitted from the main shaft to the pump, which pumps oil to the hydraulic motor. The hydraulic motor drives the gearbox output shaft. In gear I, the setting of the hydraulic motor displacement is higher than in gear II, which changes the range of available gear ratios. For both of these gears, the displacement of the main

pump can vary smoothly from zero to maximum. Thanks to this, it is possible to smoothly change the vehicle speed without the need to change the engine speed. The drive transmission in gears III and IV utilizes only a mechanical gear. For these gears the displacement of the main pump is set to zero in order not to pump hydraulic fluid and generate losses. In addition, the hydraulic motor must either be mechanically disengaged from the gearbox using the S3 clutch or actuated to a freewheeling setting. The motor, which is not disconnected from the transmission, would work as a pump, pumping oil and generating large energy losses. In order to avoid this, its displacement is set to a zero and thus, even without disengaging the S3 clutch, the motor does not generate significant losses. The choice of gear ratio III or IV depends on which clutch S1 or S2 is engaged. The S1 clutch is responsible for coupling the gear z_3 with the output shaft ω_k , setting the drive transmission to gear III, while the clutch S2 engages the gear z_5 with the input shaft ω_0 , connected to the shaft of the engine, and sets the transmission to gear IV.

Table 1. Configurations and settings of gearbox components at specific gear

Gear	Gear ratio	S1 clutch	S2 clutch	Pump displacement	Motor displacement
I	3,25- ∞	disengaged	disengaged	0-40cm ³	71cm ³
II	1,73- ∞	disengaged	disengaged	0-40cm ³	38cm ³
III	1,385	engaged	disengaged	0cm ³	0cm ³
IV	1,025	disengaged	engaged	0cm ³	0cm ³
Reverse	3,25- ∞	disengaged	disengaged	0-40cm ³ (reversed)	71cm ³

3 Methodology of efficiency testing

Preliminary tests have shown that the research of the entire assembly, which is a hydro-mechanical gearbox, is not only inaccurate, but also does not represent a great cognitive value, because they do not provide information on the location of the main energy losses, but only allow quantitative estimation of their values. In addition, these estimates are highly error-prone, as a large number of components do not allow the stabilization of influencing factors such as, among others, hydraulic fluid temperature or residual friction in the clutches[4,5]. For this reason, it was decided to carry out separate tests of the hydraulic transmission and the mechanical transmission. This approach does not limit the combination of the obtained results and the calculation of the total efficiency of the gearbox, but at the same time allows precise energy studies under steady-state conditions.

3.1 Tests of hydraulic drive

For the aforementioned reasons, the tests of the hydraulic transmission were also divided into: pump tests and hydraulic motor tests. Thanks to this approach, it was ensured that the two prototypes did not influence each other. The pump and motor are



assumed to operate in a closed-loop hydraulic system in which a relatively small volume of working liquid circulates. As a result, the temperature of the oil changes rapidly with the changing load, and the temperature stabilization system becomes very difficult to design, if not impossible. Measurements in such conditions would be burdened with a large error. Therefore, it was decided to separately test the pump and the motor connected to an open-loop system but with fluid pre-supply. About 2000 dm³ circulated in an open-loop system. This amount of oil heats up for a relatively long time, thanks to which the system equipped with water-oil coolers allows to maintain a stable temperature with an accuracy of $\pm 2^\circ\text{C}$.

Pump tests

Scheme and photo of pumps test stand is presented in Fig. 2.

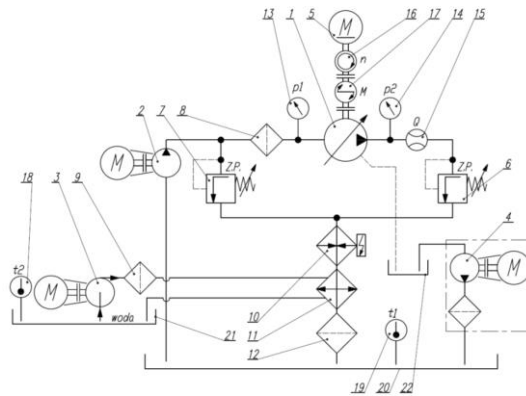

Fig. 2. Test stand for pump efficiency research

The test stand consisted of the equipment listed in the table 2. It allowed to conduct the test within specified ranges:

- Load pressure 0-35 MPa,
- Rotational speed 500-2000 rpm,
- Displacement setting 0-100%,
- Oil temperature stable settings: 25-60°C.

Table 2. Pump test stand measurement equipment

No.	Measured parameter	Equipment	Range	Class	Max. error
1	Suction pressure	Manometer MPS-02	0 - 1,6 MPa	0,2	0,006 MPa
2	Pumping pressure	Manometer KFM	0 - 40 MPa	0,6	0,25 MPa
3	Oil temperature	Thermocouple	0 - 70 °C	1	1,7 °C
4	Flow rate	Piston flowmeter PT-200	0,3 - 200 dm ³ /min	0,2	0,4 dm ³ /min
5	Torque	Torquemeter HBM T1	0 - 500 Nm	0,2	1,01 Nm
6	Rotational speed	Incremental encoder	0 - 3000 obr/min	nd.	1 obr/min

The tests were performed according to the following procedure:

1. Oil heating or cooling to the required temperature,
2. Setting of the pump displacement,
3. Setting the required pressure in the suction channel of the pump,
4. Pre-setting the speed of the pump shaft,
5. Setting the pumping pressure with the pressure relief valve,
6. Verification and possible correction of the rotational speed of the pump shaft,
7. Verification and possible correction of pumping pressure and pressure in the suction channel,
8. Readout of measured parameter values,
9. Repeat the entire procedure for changed parameters.

Based on the obtained results the firstly the theoretical displacement is calculated using the methods presented in [6,7]. The accurate value of theoretical displacement is necessary to correctly calculate the values of efficiency. The pumps efficiency consists of two partial efficiencies[8,9]: hydromechanical efficiency, which includes the pressure losses in pumps channels and mechanical losses due to friction and volumetric efficiency[10–12], which includes losses caused by leakage and fluid compressibility

The pump's hydromechanical efficiency η_{phm} is calculated using equation (1):

$$\eta_{phm} = \frac{\Delta p \cdot q_{tp}}{M_p \cdot 2 \cdot \pi} \quad (1)$$

where:

Δp – pressure difference measured between the inlet(suction) and outlet(pumping) channel,

q_{tp} – pump's theoretical displacement,

M_p – torque measured at pumps shaft,

The pump's volumetric efficiency η_{pv} is calculated using equation (2):

$$\eta_{pv} = \frac{Q_p}{n_p \cdot q_{tp}} \quad (2)$$

where:

Q_p – flow rate measured at the outlet,

n_p – rotational speed of pumps shaft,

the overall efficiency of the pump η_p is given by equation (3):

$$\eta_p = \eta_{phm} \cdot \eta_{pv} \quad (3)$$

Hydraulic motor tests

Test stand for hydraulic motor is much more complicated than the pump test stand. The motor requires to be supplied with oil under high pressure, additionally it has to be loaded with external torque source. Therefore the test stand consists of two hydraulic systems. One is responsible for oil supply for motor and the second is a loading system



in which the pump is connected to hydraulic motors shaft. Scheme and photo of hydraulic motors test stand is presented in Fig. 3. The test stand consisted of the equipment listed in the table 3. It allowed to conduct the test within specified ranges:

- Load torque 0-350 Nm,
- Rotational speed 100-1600 rpm,
- Displacement setting 100% and ~50%,
- Oil temperature stable settings: 25-60°C.

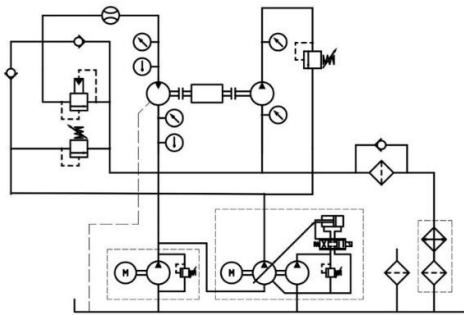

Fig. 3. Scheme of hydraulic motor test stand

Table 3. Hydraulic motor test stand measurement equipment

No.	Measured parameter	Equipment	Range	Class	Max. error
1	Return pressure	Transducer NAH Trafag	-0.1 – 1.0 MPa	0.6	0,01 MPa
2	Supply pressure	Transducer NAH Trafag	0 – 40 MPa	0.3	0,2 MPa
3	Oil temperature	Stauff PCC-04	-25 - 125 °C	1	1,4 °C
4	Flow rate	Piston flowmeter PT-200	0,3 – 200 dm ³ /min	0,2	0,4 dm ³ /min
5	Torque	Torquemeter HBM T1	0 – 500 Nm	0,2	1,01 Nm
6	Rotational speed	Incremental encoder	0 – 3000 obr/min	nd.	1 obr/min

The tests were performed according to the following procedure:

1. Oil heating or cooling to the required temperature,
2. Setting the motor displacement,
3. Pre-setting the rotational speed of the motor shaft,
4. Pre-setting the pumping pressure in the loading system,
5. Verification and possible correction of the rotational speed of the motor's shaft,
6. Verification and possible correction of pumping pressure in loading system,
7. Readout of measured parameter values,
8. Repeat the entire procedure for changed parameters.

Based on the obtained results the firstly the theoretical displacement is calculated using the methods presented in [[6,7]]. Similar the pump the accurate value of theoretical displacement is necessary to calculate the value of motor's efficiency.

The motor's hydromechanical efficiency η_{mhm} is calculated using equation (4):

$$\eta_{mhm} = \frac{M_m \cdot 2 \cdot \pi}{\Delta p \cdot q_{tm}} \quad (4)$$

where:

Δp – pressure difference measured between the inlet and outlet channel,

q_{tm} – pump's theoretical displacement,

M_m – torque measured at motor's shaft,

The motor's volumetric efficiency η_{mv} is calculated using equation (5):

$$\eta_{mv} = \frac{n_m \cdot q_{tm}}{Q_m} \quad (5)$$

where:

Q_m – flow rate measured at the inlet,

n_m – rotational speed of motor's shaft,

the overall efficiency of the motor η_m is given by equation (6):

$$\eta_m = \eta_{mhm} \cdot \eta_{mv} \quad (6)$$

3.2 Tests of mechanical gearbox

The determination of the complete characteristics of the mechanical part of the gearbox required various configurations of the test stand. The full scale tests were carried out only on gears III and IV and the efficiency of the energy transfer between the input shaft and the output shaft was tested using the configuration presented in fig. 4. For gears I and II only a partial tests were needed to research the efficiency of energy transfer:

- Transfer of energy between the input shaft and pump's shaft using configuration presented in fig. 5a.
- Transfer of energy between the hydraulic motor shaft and output shaft using configuration presented in fig. 5b.

The external load was generated using the hydraulic system acting as a load generator. The torque on the output shaft depended on the pumping pressure of the loading pump, set with pressure relief valve.

During the experimental tests, several different transducers were used to record: rotational speed of machine shafts, torque on the input shaft, torque on the output shaft, temperature of the lubricating liquid and pumping pressure of the loading pump. Table 4 lists the relevant measuring instruments along with the measurement class and ranges. As part of the research, two identical torquemeters were used - one connecting the electric motor with the gear, the other connecting the load pump with the gear.

The detailed test procedure is presented in [13].

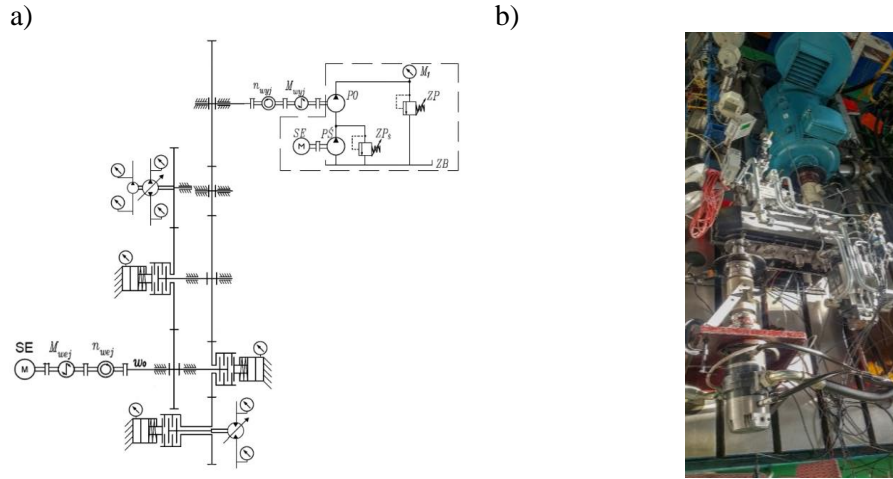

Fig. 4. Mechanical gearbox test stand in configuration for tests on III and IV gear

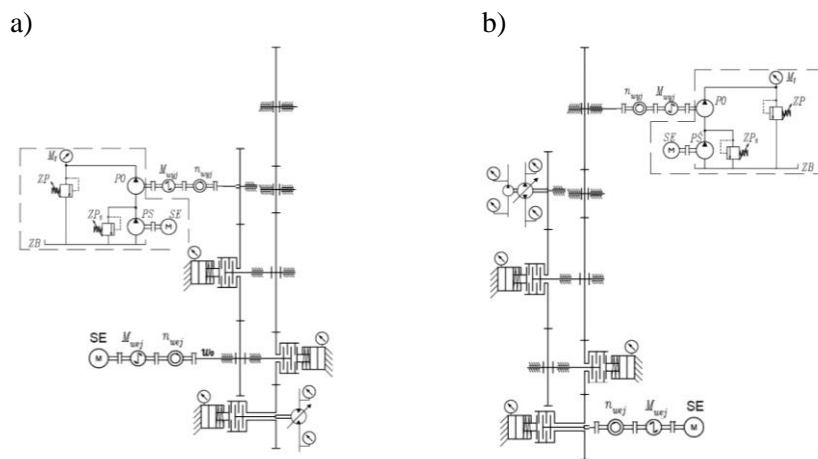

Fig. 5. Mechanical gearbox test stand in configuration for tests on I and II gear. Measurement energy transfer between: a) input shaft and pump shaft, b) motor shaft and output shaft

Table 4. Gearbox test stand measurement equipment

No.	Measured parameter	Equipment	Class	Range	Max. error
1	Pressure	Manometer	0,5	0-40MPa	2 bar
2	Torque	Torquemeter HBM T1	0,2	0-500 Nm	1,01 Nm
3	Rotational speed	Incremental encoder	-	0-60 Hz	0,017 Hz
4	Temperature	Thermocouple PT100	-	-50°C-400°C	0.5°C@40°C

4 Sample results and discussion

Using the methods and test stands presented earlier the following sample efficiency characteristics were obtained:

- volumetric, hydromechanical and overall efficiency of a pump presented in fig.6
- overall efficiency characteristics of a hydraulic motor in fig.7
- overall efficiency of a gearbox at IV gear presented in fig. 8

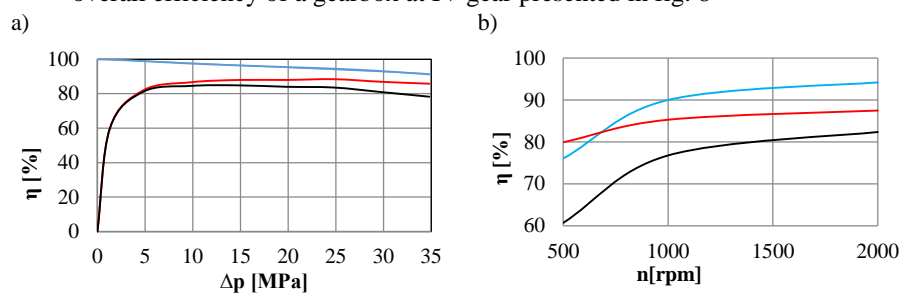

Fig. 6. Efficiency characteristics of a pump: a) as a function of pressure difference at $n=1500$ rpm; b) as a function of rotational speed at 30MPa (blue – volumetric efficiency, red – hydromechanical efficiency, black – overall efficiency)

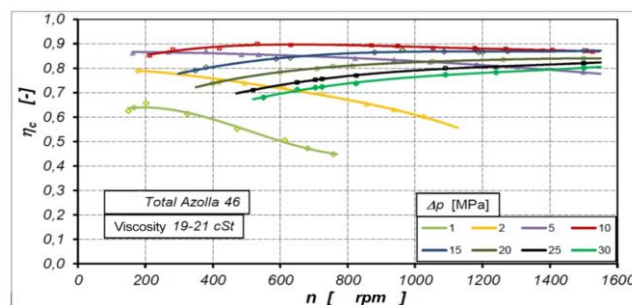

Fig. 7. Overall efficiency of a pump presented as a function of rotational speed at different pressures

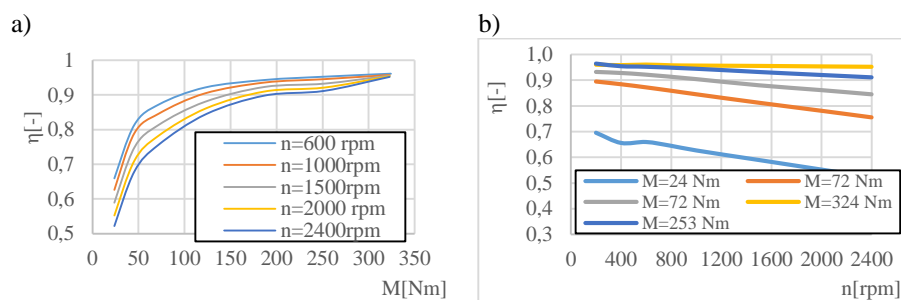

Fig. 8. Overall efficiency of the mechanical gearbox at IV gear: a) as a function of torque, b) as a function of rotational speed

Characteristics, of which very small sample was provided in the article, proved useful and significant during product development process. First of all, they allowed to verify the correctness of design assumptions and confirmed that the gearbox is working properly, achieving satisfactory operating parameters. High efficiency will translate into lower fuel consumption and thus the product will be more economical and eco-friendly. Additionally thanks to a separate analysis of the efficiency of individual components of the gearbox, it was possible to quickly locate and solve problems. For instance at the early stage of product development the increased internal leakage occurred in a pump. If the research included only the test of full gearbox the problem would remain unresolved and may become very serious in the future.

The charts of efficiency were also used to prepare the model of a complete gearbox. Using the model and providing it with required input parameters it is possible to assess very accurately the output parameters such as power loss, maximal torque and rotational speed.

Funding

This research was funded by The National Centre for Research and Development within the framework of program LIDER, grant number LIDER/22/0130/L-8/16/NCBR/2017; Project title: Hydro-mechanical automatic gearbox for agricultural vehicles and heavy machinery; Funding value: 1 197 500,00 PLN

References

1. Łopatka, M.J.; Rubiec, A. Concept and Preliminary Simulations of a Driver-Aid System for Transport Tasks of Articulated Vehicles with a Hydrostatic Steering System. *Appl. Sci.* **2020**, *10*, 5747, doi:10.3390/app10175747.
2. Kończalski, K.; Łopatka, M.J.; Przybysz, M.; Rubiec, A. Hydrostatic Drivetrains Efficiency of Slow-Moving Terrain Vehicles. *AUTOBUSY – Tech. Eksploat. Syst. Transp.* **2018**, *19*, 876–880, doi:10.24136/atest.2018.194.
3. Bury, P.; Stosiak, M.; Urbanowicz, K.; Kodura, A.; Kubrak, M.; Malesińska, A. A Case Study of Open- and Closed-Loop Control of Hydrostatic Transmission with Proportional Valve Start-Up Process. *Energies* **2022**, *15*, 1860, doi:10.3390/en15051860.
4. Bąk, M. Torque Capacity of Multidisc Wet Clutch with Reference to Friction Occurrence on Its Spline Connections. *Sci. Rep.* **2021**, *11*, 21305, doi:10.1038/s41598-021-00786-6.
5. Bąk, M.; Patrosz, P.; Śliwiński, P. Torque Transmitted by Multi-Plate Wet Clutches in Relation to Number of Friction Plates and Their Dimensions. In *Advances in Hydraulic and Pneumatic Drives and Control 2020*; Stryczek, J., Warzyńska, U., Eds.; Lecture Notes in Mechanical Engineering; Springer International Publishing: Cham, 2021; pp. 367–376 ISBN 978-3-030-59508-1.
6. Sliwinski, P. Determination of the Theoretical and Actual Working Volume of a Hydraulic Motor. *Energies* **2020**, *13*, 5933, doi:10.3390/en13225933.



7. Sliwinski, P. Determination of the Theoretical and Actual Working Volume of a Hydraulic Motor—Part II (The Method Based on the Characteristics of Effective Absorbency of the Motor). *Energies* **2021**, *14*, 1648, doi:10.3390/en14061648.
8. Jasiński, R. Volumetric and Torque Efficiency of Pumps During Start-up in Low Ambient Temperatures. In *Advances in Hydraulic and Pneumatic Drives and Control 2020*; Stryczek, J., Warzyńska, U., Eds.; Lecture Notes in Mechanical Engineering; Springer International Publishing: Cham, 2021; pp. 28–39 ISBN 978-3-030-59508-1.
9. Osiński, P.; Deptuła, A.; Partyka, M.A. Hydraulic Tests of the PZO Gear Micropump and the Importance Rank of Its Design and Operating Parameters. *Energies* **2022**, *15*, 3068, doi:10.3390/en15093068.
10. Załuski, P. Influence of the Position of the Swash Plate Rotation Axis on the Volumetric Efficiency of the Axial Piston Pumps.; Scientific technical Union of Mechanical Engineering, 2014; Vol. 11, pp. 12–15.
11. Załuski, P. Influence of Fluid Compressibility and Movements of the Swash Plate Axis of Rotation on the Volumetric Efficiency of Axial Piston Pumps. *Energies* **2022**, *15*, 298, doi:10.3390/en15010298.
12. Załuski, P. Experimental Research of an Axial Piston Pump with Displaced Swash Plate Axis of Rotation. In *Advances in Hydraulic and Pneumatic Drives and Control 2020*; Stryczek, J., Warzyńska, U., Eds.; Lecture Notes in Mechanical Engineering; Springer International Publishing: Cham, 2021; pp. 135–145 ISBN 978-3-030-59508-1.
13. Bąk, M.; Patrosz, P. Metodologia Badania Skrzyni Biegów z Wykorzystaniem Układu Hydraulicznego Jako Hamowni. *Napędy Sterow.* **2020**.