

## Modeling of Accidental Bunker Oil Spills as a Result of Ship's Bunker Tanks Rupture – a Case Study

**P. Krata & J. Jachowski**  
*Gdynia Maritime University, Poland*

**J. Montewka**  
*Aalto University School of Engineering, Espoo, Finland*  
*Maritime University of Szczecin, Poland*

**ABSTRACT:** AIS (Automatic Identification System) data analysis is used to define ship domain for grounding scenarios. The domain has been divided into two areas as inner and outer domains. Inner domain has clear border, which is based on ship dynamic characteristics. Violation of inner domain makes the grounding accident unavoidable. Outer domain area is defined with AIS data analyzing. Outer domain shows the situation of own ship in compare with other similar ships that previously were in the same situation. The domain can be used as a decision support tool in VTS (Vessel Traffic Service) centers to detect grounding candidate vessels. In the case study presented in this paper, one type of ship, which is tanker, in a waterway to Sköldvik in the Gulf of Finland is taken into account.

### 1 INTRODUCTION

The most commonly an oil accident is considered as a result of an oil tanker cargo spill. However this sort of disaster is rising the most the public awareness, hopefully cargo spills are not the most common ones (ITOPF, 2011). The most frequent oil spill accidents are those related to accidental discharges from bunker tanks of all vessels, not only tankers.

Contrary to tankers transporting heavy oil as cargo, ships' bunker tanks are not required to have a double hull structure as protection. The statistics on the oil spills provided by The International Tanker Owners Pollution Found reveal that the significant amount of oil spills of a size in a range 7-700 tones come from accidents like collisions and groundings (Fig. 1) (ITOPF, 2011).

In the past 40 years there were 1249 minor spill accidents, whereas 444 cases account for the major oil spills of a size above 700 tons, and only tankers are considered. Taking into account all types of ships this number can be expected significantly higher. These data shows that the minor size oil spills should not be neglected in any risk analysis related to maritime traffic, as they are the most frequent oil spills to occur.

At present there are two recognized and adopted methods for the bunker spill size estimation. Both of them seem to be quite general in nature and rough in results.

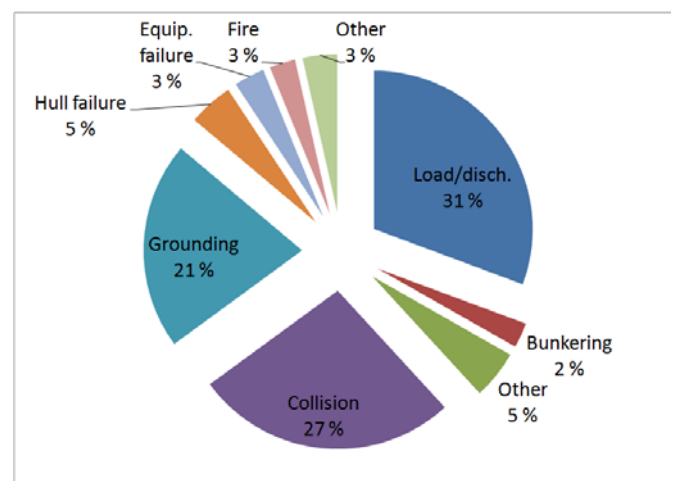

Figure 1. The distribution of causes of minor oil spills (7-700 tons) (ITOPF, 2011)

One approach is based on historical data. This approach is relatively easy, fast and straightforward, thus it has gained popularity among researches and was adopted in some general studies (HELCOM

1990, Safetec 1999, Gucma&Przywarty 2007, Nyman 2009). The limitations of this approach and its weak areas were pointed out by Michel&Winslow (1999) and Eide et al (2007), where the main concern about historical data was that they are not necessarily representative to today's accident scenarios, mostly due to changes in ship construction or layout of the tanks.

Another method, included in the IMO guidelines for approval of alternative tanker designs (IMO 1995, IMO 2003), contains a probabilistic-based procedure for estimating oil outflow performance. Probability density functions describing the location, extent and penetration of side and bottom damage are applied to a vessel's compartmentation, generating the probability of occurrence and collection of damaged compartments associated with each possible damage incident. All oil is assumed to outflow from tanks penetrated in collisions, whereas outflow from bottom damage is based on pressure balance calculations. This method sounds, however, more reliable than the previous it still lacks the time component. The method does not provide this vital information on the rate of the spill nor the time needed for tank to be released. From the preparedness and response point of view this parameter is essential, as the bunker spills occur in a close vicinity of a shore and the response time is usually very limited.

Recently a methodology has been introduced based on the analytical calculations and time domain simulations in order to calculate the volume of oil outflow and outflow rate versus time (Tavakoli et al. 2008, Tavakoli et al. 2010). The method addresses accidental cargo spills from tankers.

In this paper a method for bunker spill estimation in spatial-temporal domain is presented. The methodology takes into account the fluid dynamics, the size of a tank rupture is estimated with the use of the IMO methodology. However the damaged tank is assumed not to be a subject to longitudinal and transverse motions.

## 2 BUNKER OIL SPILL MODELING BY 3-D CFD METHODS

The technique for oil spill modeling applied in the paper makes use of Computational Fluid Dynamics. Authors propose the methodology aiming at estimation a quantity of the bunker spill, a rate of such a spill and time for the bunker to release. The method can contribute some information to the probabilistic approach utilized in previously mentioned IMO methodology. CFD based solution seems to be useful for better understanding the oil outflow process and its duration.

The proposed methodology has a wide range of applications and is free of the constraints typical for IMO statistical approach. In the paper a model for bunker spill estimation is put forward and finally a case study is presented, which is assumed as an exemplary grounding accident.

The 3-dimensional simulations of oil trickling and disseminating in water phenomenon were performed by the use of the commercial code "Fluent". The software is an universal and flexible tool designed for modeling of liquids dynamics. Most commercial CFD codes use the finite-volume or finite-element methods which are well suited for modeling flow past complex geometries (Bhaskaran&Collins). The Fluent code uses the finite-volume method (FVM), and uses the volume of fluid (VOF) method for free surface problems (Dongming&Pengzhi 2008, Fluent 2006).

The numerical simulations of the oil dispersing in water phenomenon were performed for a number of damage extend configuration (Fig.4) and tank geometry corresponding to the relevant parameters of the selected bulk carrier. The cross section of a vessel and the location of a damaged double bottom tank is shown in Figure 2.

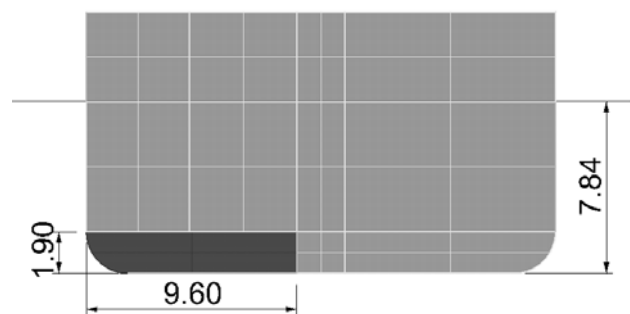

Figure 2. The cross section of a ship and her double bottom tank to be ruptured

In the course of the study a typical double bottom bunker tank of an exemplary bulk carrier is considered. The characteristic dimensions of the damaged tank are as follows:

- length – 40.0 m;
- breadth – 9.6 m;
- double bottom height – 1.9 m.

The shape of the double bottom bunker tank is presented in Figure 3.

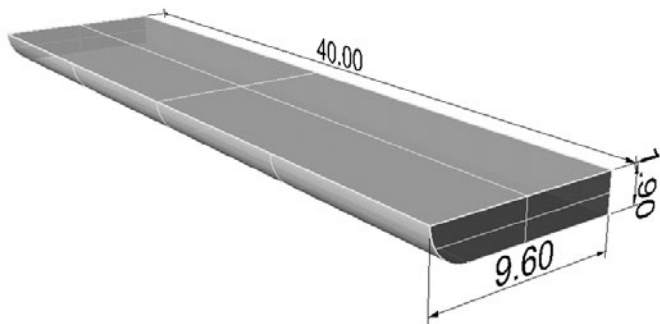

Figure 3. The damaged tank shape and dimensions

A leakage of bunker oil might take place due to a variety of reasons among which collision or grounding are the most common (Fig.1). There are available statistical analyses of damage locations in all three dimensions within ships hulls and damage extends. Usually collision and grounding are researched separately and nowadays some widely accepted distributions of hull damage size are in use.

Nevertheless the diversity of damage location is noticed, for the purpose of the case study one exemplary double bottom tank is considered and one elevation of the damage above the ship keel. The vertical extend of tank damage and its location is shown in Fig. 4.

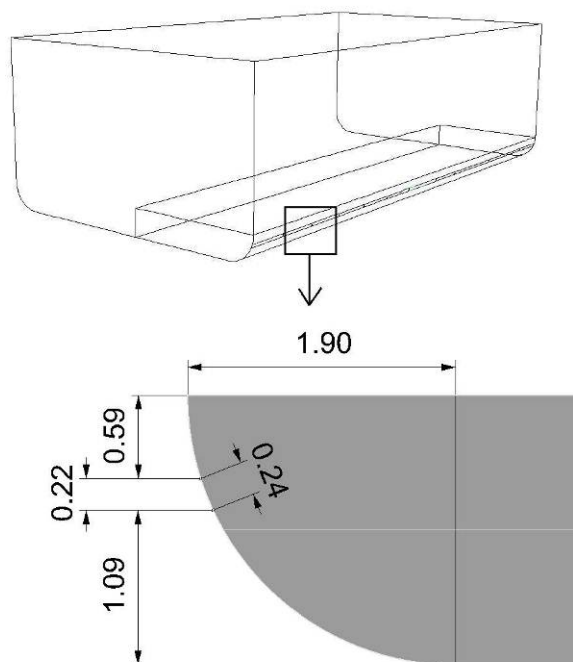

Figure 4. The location and span of the damage in double bottom tank (an exemplary case study)

The numerical simulations of oil spill were carried out for a number of tank damage lengths, i.e. 10%, 40%, 70%, 85% and 100% of compartment

length (Fig. 5). This was to estimate how far nonlinear effects influence the final results, especially in terms of a rate of the outflow. The variable damage length was modeled by the use of removable panels concept which was convenient from the computational mesh creation point of view.

When the considered geometry of the damaged tank was established a set of assumptions required for the numerical simulations needed to be set up. The assumptions are related to the computational mesh creation, Courant number range, time step, fluid viscosity modeling, etc. Then the boundary conditions were defined.

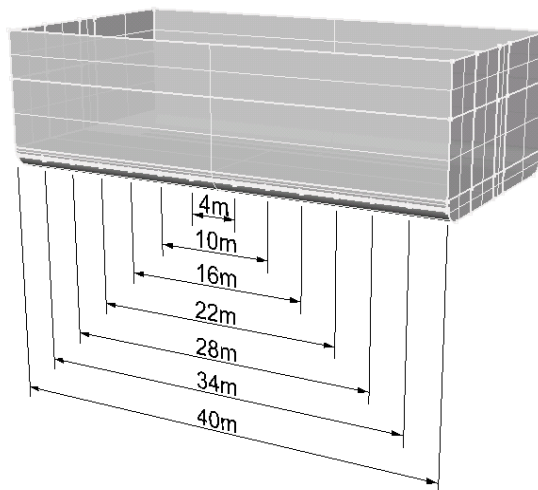

Figure 5. Removable panels used for modeling of different length shell damage

A variable computation time step was applied in the solution of the conservation equations for mass, momentum, and volume fraction of the both liquids water and oil. All numerical simulations were based on a 3D quadrilateral mesh created in GAMBIT. The setup of computational mesh is shown in Fig. 6.

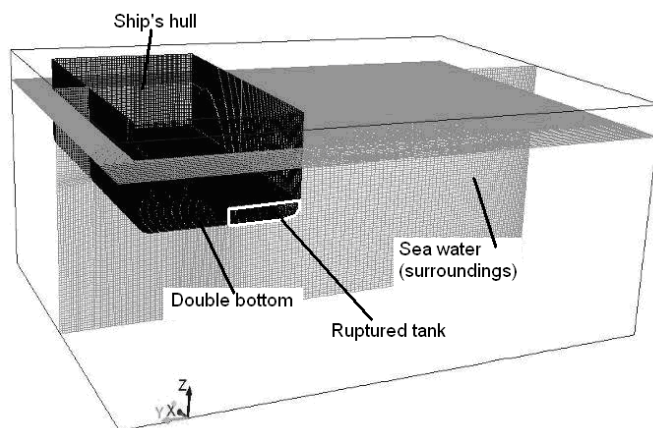

Figure 6. The computational mesh applied in 3D simulations performed by use of Fluent code

The computational mesh contains the considered section of the damaged ship (see Fig. 2 & 4) and a cuboid of surrounding water. The adjustment of mesh geometry is one of the key points of CFD modeling.

In the finite-volume method, such a quadrilateral is commonly referred to as a “cell” and a grid point as a “node”. In this approach, the integral form of the conservation equations are applied to the control volume defined by a cell to get the discrete equations for the cell (Bhaskaran&Collins 2009).

The Fluent code is to find a solution such that mass, momentum, energy and other relevant quantities are being conserved for each cell. Also, the code directly solves for values of the flow variables at the cell centers; values at other locations are obtained by suitable interpolation (Bhaskaran&Collins 2009).

The Fluent code is designed to solve the Reynolds Averaged Navier Stokes (RANS) equations. RANS equations govern the mean velocity and pressure. These quantities vary smoothly in space and time, thus they can be relatively easy to solve; however they require some additional modeling to “close” the equations and these models introduce significant error into the calculation (Bhaskaran&Collins 2009).

In the course of the computation the variable time steps were applied in order to solve the conservation equations for mass, momentum, and volume fraction of the liquid. A concept of a VOF model is based on the monovalent assignment of liquid density inside every single computational cell (Fig. 7).

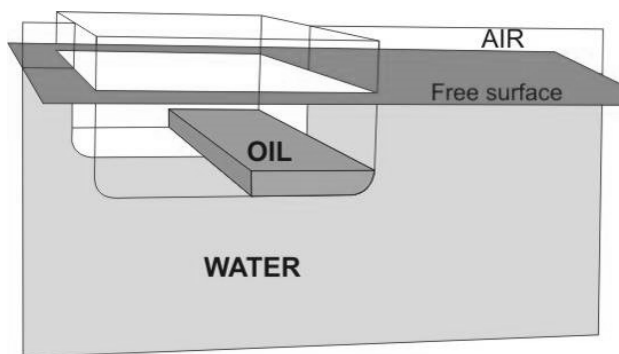

Figure 7. The mixture density concept in VOF model and mesh formulation for bottom damaged tank - at the time  $t=0s$  the oil starts to flow out of a crack (see Fig. 6 for clarification of the ruptured tank location)

Due to modeled fluids characteristics and relatively low value of expected Reynolds number, the laminar flow is applied in the course of numerical simulations. The laminar flows are characterized by pretty smoothly varying velocity fields in space and time in which individual layers

move past one another without generating noticeable cross currents. These flows arise when the fluid viscosity is sufficiently large to damp out any perturbations to the flow (Bhaskaran&Collins 2009).

### 3 RESULTS OBTAINED IN THE COURSE OF CFD COMPUTATION - A CASE STUDY

The most straightforward attitude towards bunker oil spills consideration is just to carry out the series of simulations of an oil outflow. The methodology proposed in the paper is based on a CFD modeling. The simulations were performed on the basis of conditions and assumptions described in the previous sections of the paper.

The results of computations can be analyzed from variety viewpoints. The first outcome of the simulations is a visualization of flow patterns during the spilling process. This provides a general outlook on the considered phenomenon and helps to imagine the possible course of action in case of ship hull damage (Fig. 8).

The next result of CFD computation is a possibility of the velocity vector field visualization (Fig. 9). This is to facilitate the description of an oil outflow consecutive stages and its interpretation. In the Figure 9 the velocity vectors of the oil outflow from a tank can be noticed. Moreover, the velocity vectors of water flooding a tank may be also indentified.

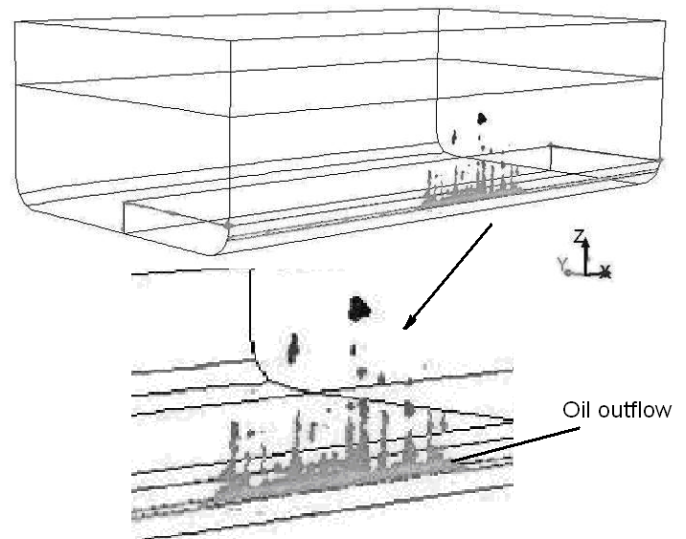

Figure 8. A typical flow pattern obtained for bunker oil outflow by the use of CFD simulations

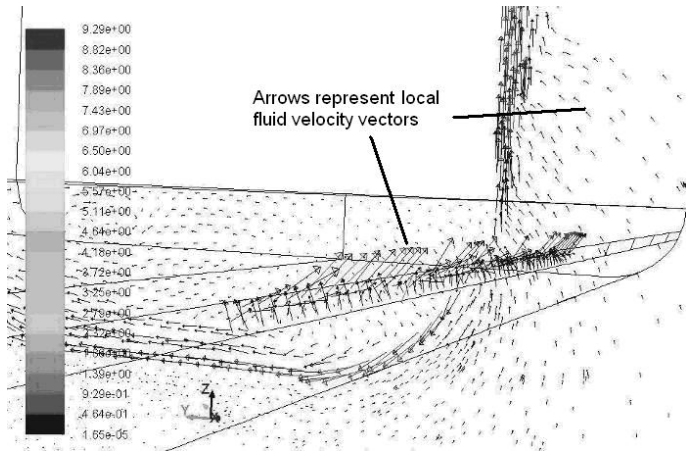

Figure 9. The velocity vector field visualization

However the main purpose of the CFD simulations was to estimate the volume of the oil spilled to the sea. It is important that the result obtained are time dependent. Thus the maximum allowed time for oil combating action may be assessed. The exemplary progress of the bunker oil outflow is shown in Figure 10. The percentage given in the graph refers to the length of hull damage according to the Figures 3 and 5.

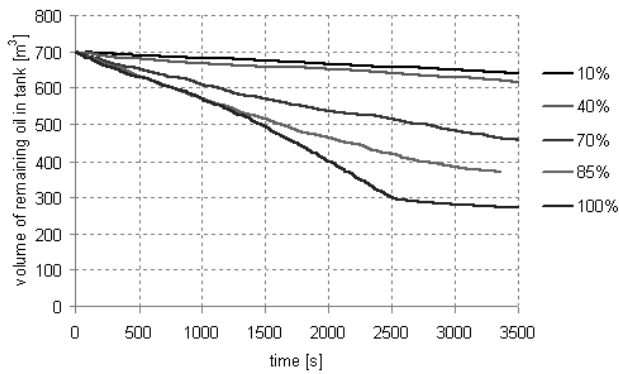

Figure 10. The volume of remaining oil in a damaged bunker tank (the initial volume of full tank was equal 700 m<sup>3</sup>)

The graphs plotted in Figure 10 seems to be rather smooth but one should keep in mind that they have a cumulative character describing the volume of oil remaining in the damaged tank. However, the rate of an oil spill is not a steady value while the oil trickling and disseminating in water phenomenon is not a stationary process.

The rate of oil discharge was computed and plotted for a time span of carried out CFD simulations. A number of graphs present the results of computations. The oil outflow rate obtained for the length of damage equals 25% of the section length is shown in Figure 11. And respectively: for 70% - in Figure 12, 85% - Figure 13 and 100% - Figure 14.

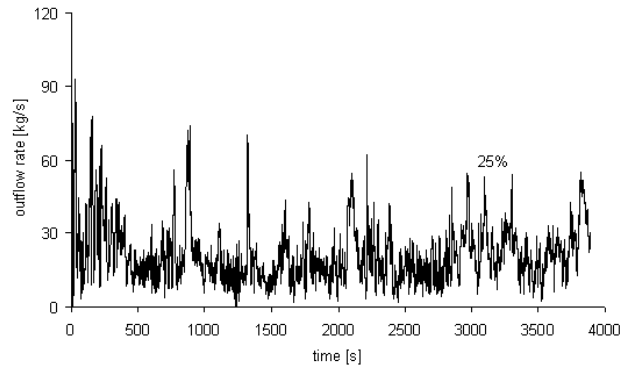

Figure 11. The rate of an oil outflow for the length of damage equal to 25% of considered section's length

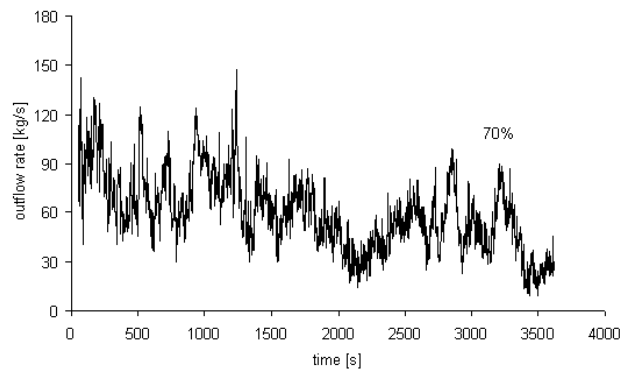

Figure 12. The rate of an oil outflow for the length of damage equal to 70% of considered section's length

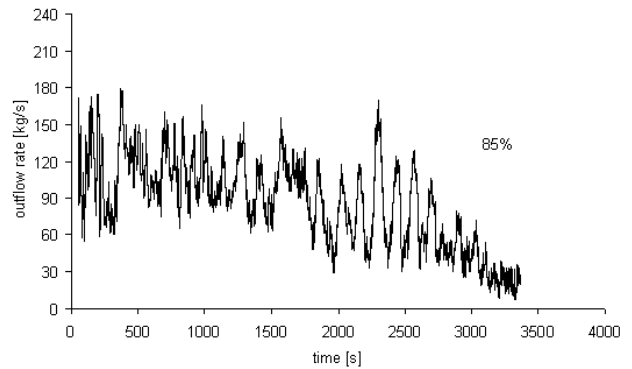

Figure 13. The rate of an oil outflow for the length of damage equal to 85% of considered section's length

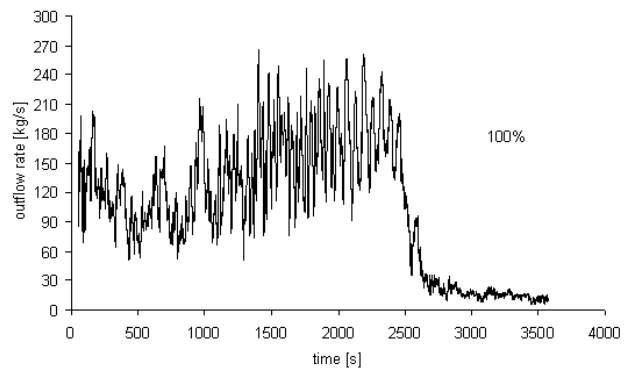

Figure 14. The rate of an oil outflow for the length of damage equal to 100% of considered section's length

The most typical feature of the computed oil discharge rate is its unstable character in terms of time. The hint to the explanation of this observation might be the flow pattern presented in Figure 8. The visualization reveals bubble-like character of the oil outflow resulting in variable value of the oil discharge rate.

All the results of performed CFD computations are rather coarse due to the adopted assumptions at the preliminary stage of the research. Thus, the upper limit of the Courant number was accepted relatively high and the computational mesh was generated not very dense. Such assumptions are justified for a feasibility study and obviously they will be modified for the planned main research purposes to obtain the expected satisfactory level of accuracy.

#### 4 SUMMARY

The study presented in the paper is a preliminary stage of the planned research and should be rather found as a practical approach to the feasibility study not the final result. However, a number of remarks and conclusions may be drawn.

First of all the realistic possibility of an application of CFD method to the bunker oil spill problem is revealed. The accuracy of computation may be improved by generation of larger size of meshes and lowering the limit of accepted Courant number.

From the point of view of shipping stakeholders the key point of the study is a remark, that CFD application enables estimation of bunker spill characteristics at the design stage of a ship. A variety of scenarios (different layouts of bunker tanks) can be examined and compared against the expected size of an oil spill.

Contrary to contemporary utilized methods, the method presented in this paper provides a number of advantages like time dependent characteristics of spilled oil volume and a rate of discharge. Such data might be useful also in the course of planning and conducting an oil combating action.

The flexibility of presented CFD-based approach benefits with strictly desirable proactive character of

the method which is a good prospective for future research in the field of oil spills protection in the marine industry.

#### REFERENCES

- Bhaskaran R., Collins L., Introduction to CFD Basics, Cornell University, New York, 2009, <http://dragonfly.tam.cornell.edu/teaching/mae5230-cfd-intro-notes.pdf>.
- Dongming Liu, Pengzhi Lin, A numerical study of three-dimensional liquid sloshing in tanks, *Journal of Computational Physics* 227 (2008), pp. 3921–3939, 2008.
- Eide, Magnus S., Øyvind Endresen, Øyvind Breivik, Odd Willy Brude, Ingrid H. Ellingsen, Kjell Røang, Jarle Hauge, and Per Olaf Brett, Prevention of oil spill from shipping by modelling of dynamic risk. *Marine Pollution Bulletin* 54, no. 10 (October), pp. 1619-1633, 2007.
- FLUENT Tutorial Guide, Fluent Inc. 2006.
- Gucma L., Przywarty M. 2007. Probabilistic method of ship navigational safety assessment on large sea areas with consideration of oil spills possibilities. In Taerwe&Proske (eds) 5th International Probabilistic Workshop, Ghent, pp.349-362, 2007.
- HELCOM. 1990. Study of the Risk for Accidents and the Related Environmental Hazards from the Transportation of Chemicals by Tankers in the Baltic Sea Area. *Baltic Sea Environment Proceedings No. 34*. Helsinki Commission 1990.
- IMO, Interim guidelines for approval of alternative methods of design and construction of oil tankers. Regulation 13F(5) of Annex I of MARPOL 73/78, Resolution MEPC.66(37), 1995.
- IMO, Revised interim guidelines for the approval of alternative methods of design and construction of oil tankers. Regulation 13F (5) of Annex I of MARPOL 73/78 Resolution MEPC.110(49), 1993.
- ITOPF, Information services / data and statistics. ITOPF. <http://www.itopf.com/information-services/data-and-statistics/statistics/index.html#no>, 2011.
- Michel K., Winslow T., Cargo Ship Bunker Tanks: Designing to Mitigate Oil Spillage. SNAME Joint California Sections Meeting, 1999.
- Nyman T. Evaluation of methods to estimate the consequence costs of an oil spill. 7 FP report, SKEMA study, 2009.
- Safetec UK. Identification of Marine Environmental High Risk Areas (MEHRAs) in the UK. Doc. No.: ST-8639-MI-1-Rev 01. December 1999.
- Tavakoli M.T., Amdahl J., Ashrafian A., Leira B.J. Analytical predictions of oil spill from grounded cargo tankers. Proceedings of the ASME 27<sup>th</sup> International Conference on Offshore Mechanics and Arctic Engineering, Estoril, Portugal, 2008.
- Tavakoli M.T., Amdahl J., Leira B.J. Analytical and numerical modelling of oil spill from a side damaged tank. In Ehlers and Romanoff (eds) 5th International Conference on Collision and Grounding of Ships, Espoo 2010.