

archives  
of thermodynamics

Vol. 40(2019), No. 3, 109–121

DOI: DOI: 10.24425/ather.2019.129996

## Modeling of the internal combustion engine cooling system

ZBIGNIEW KNEBA\*

Gdańsk University of Technology, Narutowicza 11/12, 80-233 Gdańsk, Poland

**Abstract** The article concerns computer modelling of processes in cooling systems of internal combustion engines. Modelling objectives and existing commercial programs are presented. It also describes Author's own method of binding graphs used to describe phenomena in the cooling system of a spark ignition engine. The own model has been verified by tests on the engine dynamometer. An example of using a commercial program for experimental modelling of an installation containing a heat accumulator is presented.

**Keywords:** Modeling; Combustion engine; Cooling system

### Nomenclature

$A$	–	heat exchange area
$C_v$	–	specific heat of the element at a constant volume
$i$	–	enthalpy
$\dot{Q}$	–	rate of heat flow
$k$	–	heat transfer coefficient
$m$	–	mass of the element
$\dot{S}$	–	rate of entropy flow
$T$	–	temperature
$\mathbf{U}$	–	vector of controls (inputs)
$\mathbf{X}$	–	vector of state variables
$\mathbf{Y}$	–	vector of result parameters

---

\*Email: zkneba@pg.edu.pl

**Abbreviation**

C	–	(before next letters) capacity
R	–	(before next letters) resistance
A	–	elements dissipating heat energy to the environment at the assumed temperature
CC	–	combustion chamber as the only source of thermal energy
CO	–	oil cooler (optional)
COO	–	coolant
CW	–	coolant cooler
M	–	metal (engine parts)
OP	–	oil pump
OT	–	oil tank
satu	–	nucleate boiling
W	–	wall
WP	–	coolant pump
WT	–	coolant container

## 1 Introduction

The reduction of CO<sub>2</sub> emissions is nowadays the most important issue with respect to toxic gaseous emissions. The exhaust aftertreatment systems have such high efficiency that CO<sub>2</sub> content lowering is the next step needed. The engine thermal management is one of the most promising and low cost solutions for achieving better exhaust. Engine cooling system as a part of heat usage thermal management system. Thermal energy which is the main product of the internal combustion engine could be managed by combined contributions of several systems. For example in vehicles there are such systems as: engine water cooling, engine oil cooling, intake air cooling, exhaust temperature management, and passenger compartment air conditioning. Exhaust catalysts have had a remarkable role in decreasing pollutants and there is a direct relation between their performance and exhaust gas temperature.

There are two types of heat that must be rejected namely the static heat and the hysteresis heat. The static heat appears in constant load conditions and is determined by constant temperature set in the water cooling system [1], the hysteresis heat is generated only during the transient load. The optimum temperature for coolant and oil is sought by modelling and also by experiments [2]. Oil viscosity varies with temperature, so as the oil temperature changes, the engine friction will also change. Research has shown that at half load, friction may decrease by up to 10% due to the increase in lining temperature (although in this situation dry friction may possibly in-

crease) [3]. One factor preventing high temperatures in the lining is the oil viscosity reduction, which results in mixed-friction at piston dead centers. Although a 30 °C rise in temperature will increase friction at the piston dead center, the total friction loss over the entire range of piston motion will actually decrease by 20% due to the decrease in oil viscosity corresponding to this temperature rise [3]. When the engine is working in a partial load situation, increasing engine temperature can result in more efficient combustion. For example, increasing engine temperature to approximately 110 °C will decrease fuel consumption by up to 5% and decrease emissions by up to 20% for CO and 10% for HC [5]. On the other hand, when the engine is operating in a full load situation (such as when climbing a hill), the resulting high temperatures can cause harmful engine knocking. Thus, temperature should be decreased in full load situations.

## 2 Modeling tools

Mathematical models of the thermal system in which combustion engine (CE) is the source of heat are described in literature [7]. Specialist centers producing simulation software run numerous works in this area. The most famous in Europe are the Kompetenzzentrum Das virtuelle Fahrzeug Forschungsgesellschaft Gratz Austria, AVL Gratz Austria, LMS (formerly Imagine) Roane France and in the United States the GT Cool, respectively. The integration of various programs is the most difficult task. The modeling uses very specialized programs like Kuli, less targeted like AmeSim [4,5], but also very universal ones like Flowmaster or Simulink. There are two ways to merge codes into one system: two-way data exchange between submodels and the development of a master control program. An example of commercial software is shown in Figs. 1 and 2. To be more precisely some engine subsystems are modeled separately and then connected with other subsystems or even surroundings. The example of this approach is presented in Fig. 2.

## 3 Synthetic model of the cooling system

The author of [5] proposed a uniform approach to modeling the energy systems, with different types of energy, using bond graphs and state equations. The modeling of the vehicle's energy system, with particular emphasis on the operation of the cooling system, has been developed in an annex to



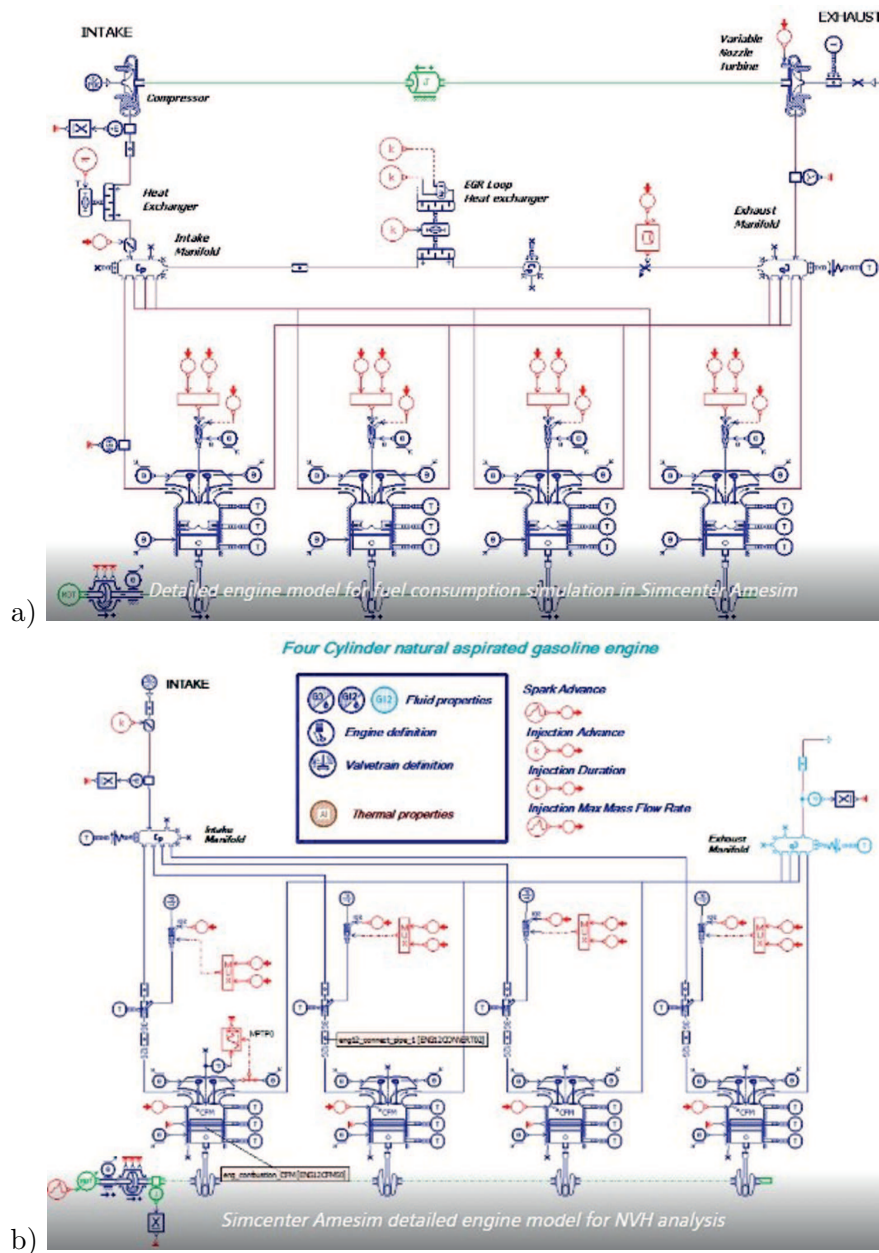

Figure 1: Detailed engine model for heat release in Simcenter Amesim: a) turbocharged, b) naturally aspirated [6].

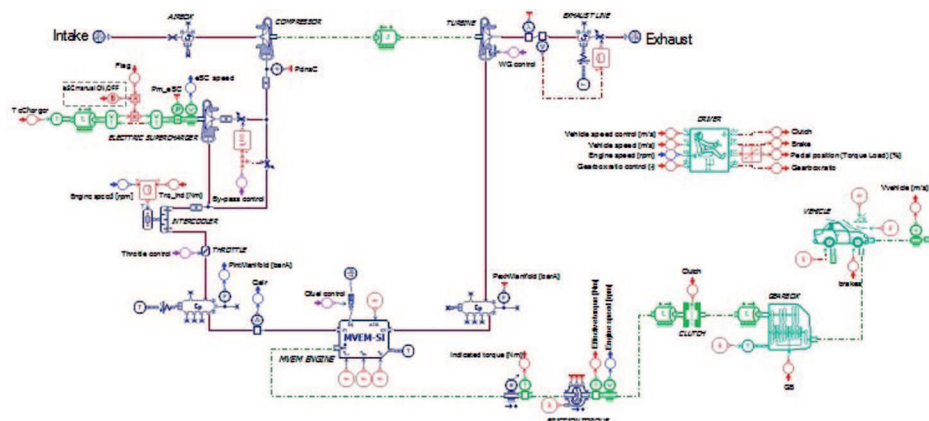

Figure 2: Interaction of different systems [6].

the report on the research project. This section describes the cooling system models with the extension of the heat accumulation description. For a more synthetic presentation of the models, the binding graphs method was adopted as the most suitable for modeling energy systems with complex physical nature. This method has been developed for many years at the Chair of Combustion Engines and Compressors of the Faculty of Mechanical Engineering at the Gdansk University of Technology in the group of prof. Marian Cichy [7].

The system: car engine, engine cooling system and vehicle power train processes various types of energy. The dominant types of energy are thermal energy, mechanical and hydraulic energy. Electricity is also gaining more and more importance today. The first step in building a complex object model, which is a vehicle, is division into teams whose energy inputs and outputs can be described. This work focuses on the next-generation cooling system for a car combustion engine.

Models in the form of bond graphs and state equations are the dynamic models with clustered parameters. The construction of the model includes two stages. The first is the division of the facility into independent energy stores, building a model of bond graphs and energy collection and dissipation. The second stage is the use of the laws of physics describing the accumulation, flow and dissipation of energy for the derivation of state equations. At this stage, a mathematical model is created in the form of

state equations:

$$\begin{aligned}\dot{\mathbf{X}} &= f_1(\mathbf{X}, \mathbf{U}) , \\ \mathbf{Y} &= f_2(\mathbf{X}, \mathbf{U}) ,\end{aligned}\quad (1)$$

where:  $\mathbf{X}$  – vector of state variables,  $\mathbf{U}$  – vector of controls (inputs),  $\mathbf{Y}$  – vector of result parameters, overdot denotes time derivative,  $f_1$  – first order differential equation system,  $f_2$  – algebraic equation system.

In many cases, energy processes are so complex that building a bond graph (BG) model for them, using only the laws of physics, is practically impossible. In this case, the model is built in the form of a ‘black box’, using the relationships between energy parameters obtained by measurements. Examples of such processes include the combustion process in an internal combustion engine [5], or the process of converting electrical energy into the mechanical one in the electric motor [8]. The models should enable the optimization of the characteristics and parameters of the facility, its method of control and operation. Using the model for the aforementioned tasks requires its verification by measuring energy parameters and other parameters characterizing the object.

The cooling system was divided into 7 independent thermal energy stores, namely:

- M1 – metal elements of the engine that take up heat from the gases in the combustion chamber,
- M2 – metal elements of the engine that have contact with the environment and other elements inside the engine but have no wall in the combustion chamber,
- M3 – elements inside the engine that do not have a wall either in the combustion chamber or outside the engine,
- M4 – metal elements in contact with gases during combustion and transferring heat to lubricating oil without heat accumulation,
- M5 – metal elements transferring heat to oil and accumulating thermal energy,
- OT – oil tank having contact with the environment,
- WT – coolant tank inside the engine, channels and spaces of cooling liquid in the cylinder block and head.

The diagram of the engine cooling system division into elements is shown in Fig. 3. The diagram also includes other elements needed to build a cooling system model, such as: CC – combustion chamber as the only source of thermal energy, A – elements dissipating heat energy to the environment at the assumed temperature, CW – coolant cooler, WP – coolant pump,

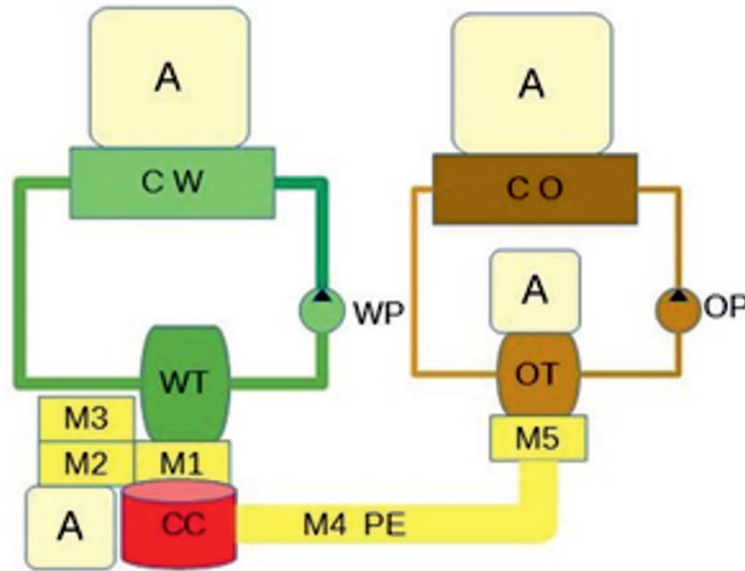

Figure 3: Diagram of the engine cooling system division into elements.

OP – oil pump, OT – oil tank, CO – oil cooler (optional), WT – coolant container. The first step in formulating state equations is to determine the vector of  $\mathbf{X}$  state variables for thermal energy accumulators, which can be represented in the following form:

$$\mathbf{X} = [T_{M1} \ T_{M2} \ T_{M3} \ T_{WT} \ T_{CW} \ T_{M5} \ T_{OT} \ T_{CO}]^T \quad (2)$$

where symbol  $\top$  denotes the transpose of a vector.

The arrangement of 8 basic equations of state is made directly on the basis of the GW graphic model according to the general dependence for each thermal energy 'C':

$$T_C \dot{S}_C = \sum_{i=1}^{N_C-1} T_{iC} \dot{S}_{iC} , \quad (3)$$

where  $T_C$  is the temperature of a single thermal energy accumulator (e.g. engine block),  $\dot{S}_C$  is the rate of entropy flow for this accumulator, and  $N_C$  is the number of graphs in the node containing the C-graph. The C-graph is the graph connected with the capacity element [7]. The left part of Eq. (3) shows the heat flow of charging and discharging the thermal energy

accumulator, which for the fixed mass elements will be expressed by the dependence

$$T_C \dot{S}_C = \dot{T}_C m C_v, \quad (4)$$

where  $\dot{T}_C$  is the temperature of this accumulator,  $m$  is the mass of the element, and  $C_v$  is specific heat of the element at a constant volume.

The next step in the arrangement of state equations is to present each component of the sum on the right side of Eq. (3) in the form of dependence on the state variables  $\mathbf{X}$ , using the theory of thermal processes, or in the form of independent time functions, which in Eq. (1) are elements of the control vector  $\mathbf{U}$ . There are 7 thermal energy batteries because the thermal capacity of the oil cooler is omitted (the cooler volume is small compared to other parts of the system. The system of state equations can be presented as follows:

$$\begin{aligned} T_{M1} \dot{S}_{CM1} &= T_{CC} \dot{S}_{CC} - T_{CC} \dot{S}_{CCO} - T_{M1} \dot{S}_{M1M2} - T_{M1} \dot{S}_{M1WT}, \\ T_{M2} \dot{S}_{CM2} &= T_{M1} \dot{S}_{M1M2} - T_{M2} \dot{S}_{RM2} - T_{M2} \dot{S}_{M2M3}, \\ T_{M3} \dot{S}_{CM3} &= T_{M2} \dot{S}_{M2M3}, \\ T_{WT} \dot{S}_{CWT} &= T_{M1} \dot{S}_{M1} - i_{CW} \dot{m}_W - i_{ZW} \dot{m}_W, \\ T_{CW} \dot{S}_{CWT} &= T_{M1} \dot{S}_{M1} - i_{CW} \dot{m}_W - i_{ZW} \dot{m}_W, \\ T_{M5} \dot{S}_{CM5} &= T_{CC} \dot{S}_{CC} - T_{M5} \dot{S}_{M5}, \\ T_{OT} \dot{S}_{COT} &= T_{M5} \dot{S}_{M5} - T_{M5} \dot{S}_{ROT}. \end{aligned} \quad (5)$$

The introduction of Eqs. (5) to the form (1) requires substitution for the left sides of this equation right side of Eqs. (2).

#### 4 Some examples of simulation of the engine warm-up process and heat accumulation using models

In order to verify the developed model of the cooling system, simulation of the spark-ignition (SI) car engine heating process was performed and the course of selected temperatures with the measurement result in the laboratory was compared. A sudden increase of the inside wall temperature of the cylinder up to 400 °C was assumed, and then the selected temperatures were calculated assuming the initial temperature of the cooling liquid equal





to 20 °C. The fixed capacity of the coolant pump was assumed to be equal to 0.5 kg/s. The actual values of the model constants were determined during many tests on the engine dynamometer (Fig. 4). The constants needed to examine were the heat resistance. The 1.8 l SI engine [citation needed] was used for model validation. In addition, parts of the engine and its fluids were dismantled and weighed. The result of the simulation modelling the process of engine warm up is shown in Fig. 5.



Figure 4: Engine test bat in the laboratory.

Heated warming processes were tested and the results were used to calibrate the model. Multiple tests were carried out on the engine dynamometer. The results were supplemented with earlier measurements on the chassis dynamometer and in the operation of cars. They indicated that by describing the process of heating up the engine, the temperature course of the liquid can be approximated with the 5th degree polynomials. In limited temperature ranges, this waveform can be approximated with straight lines. Graphs in Fig. 5. show the temperature variation of the sleeve during warm-up for constant engine load.

During the design of the new cooling system, the selection of the volume of the additional liquid heat accumulator was the object of separate tests. For this purpose, a mathematical model simulating the operation of the cooling system was built using the commercial AmeSim 7.0 program, which includes the additional closed circuit with a liquid tank. A schematic

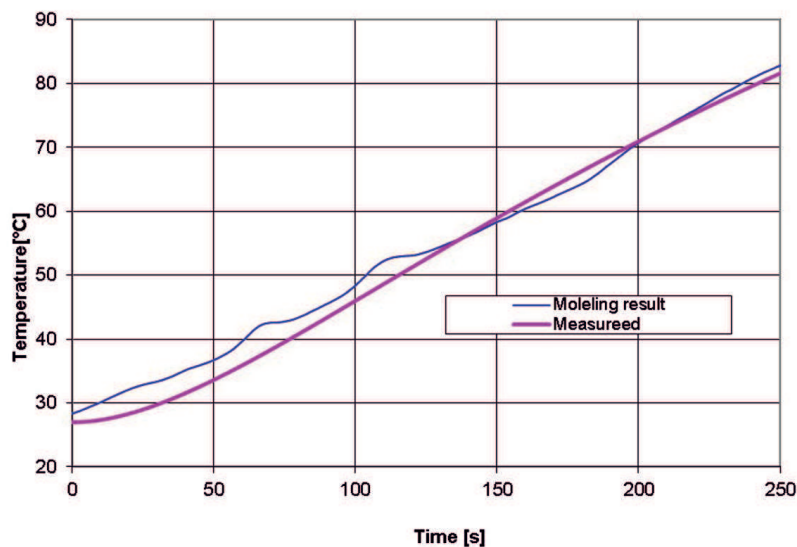

Figure 5: The temperature of the combustion chamber wall at a depth of 0.002 m under the cylinder liner results from the modelling and measured on the dynamometer in the M111920 engine [author's measurements].

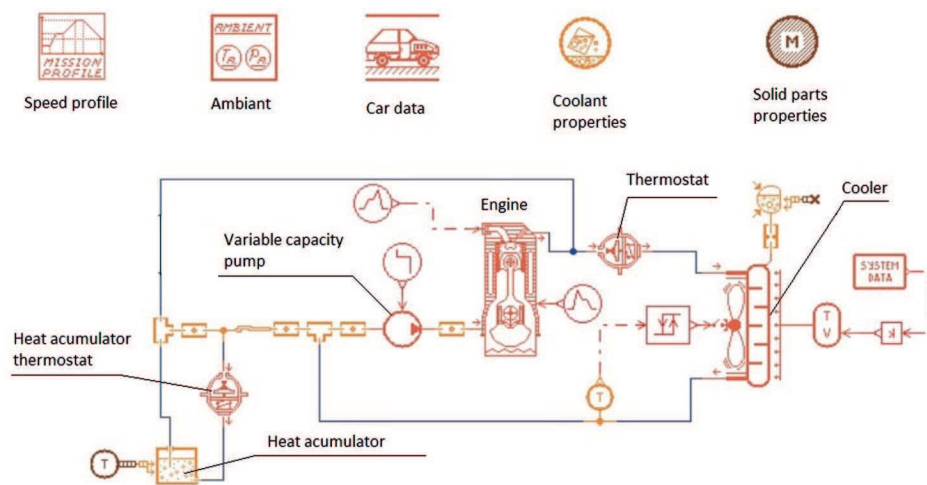

Figure 6: Diagram of a simulation cooling system with thermal energy accumulation. Scheme developed for the case of heat energy storage [5].

diagram of the cooling system model for simulation studies of heat energy accumulation is shown in Fig. 6.

Cooling system control has been designed in such a way that the heat accumulation after the cooling liquid leaving the head reaches the temperature of  $50^{\circ}\text{C}$ . By means of the opening valve, the heat accumulator is automatically put into circulation starting the process of its accumulation. The use of accumulated heat to heat the engine coolant is activated before the engine is started, or when it is started, by switching on the coolant pump with the bypass solenoid valve.

During the simulation tests, the car was programmed to drive uphill with a slope of 6%, at a speed of 45 km/h, for 300 s. The temperature of the coolant at the time the engine was started was equal to the ambient temperature and was  $20^{\circ}\text{C}$ . The temperature of the thermostat opening was set at  $88^{\circ}\text{C}$  and full opening –  $100^{\circ}\text{C}$ . The course of the engine's heating and heat accumulation process is shown in Fig. 7.

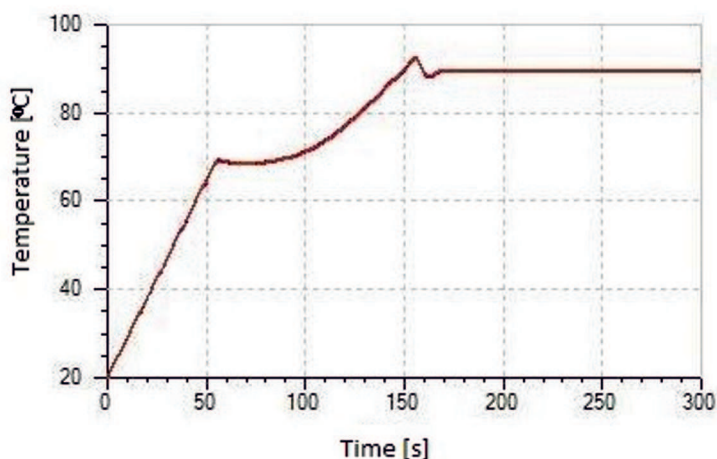

Figure 7: The temperature of the liquid flowing out of the head during the warm up of the engine with the heat accumulation on [5].

From the temperature course in the drawing it can be seen that the process of heat accumulation started after the temperature of the cooling liquid has been raised to  $70^{\circ}\text{C}$ , which occurred in 55 s since the engine was started. After 155 s, the thermostat started to work, including the coolant flow through the radiator. The heat accumulated in the heat insulated additional coolant tank can be used to heat the engine coolant during its subsequent warm-up, by activating the coolant pump with the bypass solenoid valve closed.

## 5 Model of cooling system including nucleate boiling

In [10] it is proposed to add to the equation defining the forced convection a part responsible for nucleate convection

$$\dot{Q} = k_{\text{forced}} A (T_M - T_{\text{COO}}) + k_{\text{sat}} A_{\text{satu}} (T_M - T_{\text{sat}}), \quad (6)$$

where:  $\dot{Q}$  – rate of heat flow,  $k_{\text{forced}}$  – forced convection, heat transfer coefficient,  $k_{\text{sat}}$  – nucleate boiling heat transfer coefficient,  $A$ ,  $A_{\text{satu}}$  – heat exchange areas,  $T_M$  – walls temperature,  $T_{\text{coo}}$  – coolant temperature,  $T_{\text{sat}}$  – saturation temperature.

Nucleate boiling is currently accepted on small surfaces inside the head. The new cooling systems avoid boiling in larger volumes of the cooling space by increasing the pressure of the cooling liquid. It is difficult to determine the coefficient of heat exchange in geometrically complex channels inside the head, although there are numerous papers devoted to the determination of such coefficients, for example [9].

## 6 Summary

The simulation of the heating process showed the imperfection of calculation methods. Figure 5 shows significant discontinuities in the warming curve. In the face of such difficulties, most companies producing commercial software force their users to enter many equalization correction factors into mathematical models (Fig 6). Because there are significant changes in the construction of engines such as: introduction of high-pressure recharging, direct injection into the cylinder, increasing the amount of recirculated exhaust gases or additional motor propulsion of the motor shaft, thus, the models get complicated from drives with other structural features.

Modeling of cooling systems for internal combustion engines is particularly useful in the initial design of new liquid circuits in the engine, selection of other devices and diagnostics. Introduced in the form of characteristics of discrete properties of new components give the opportunity to select other devices at the design stage. In turn, within the framework of diagnostics, the model operates in real time, determining the expected work parameters.

*Received 12 December 2018*

## References

- [1] YOO I.K., SIMPSON K., BELL M., MAJKOWSKI S.: *An Engine Coolant Temperature Model and Application for Cooling System Diagnosis*. SAE International, 2000.
- [2] HAGHIGAT A.K., ROUMI S., MADANI N., BAHMANPOUR D., OLSEN M.G.: *An intelligent cooling system and control model for improved engine thermal management*. Appl. Therm. Eng. **128**(2018), 253–269.
- [3] KOCH F.W., HAUBNER F.G.: *Cooling System Development and Optimization for DI Engines*. SAE International, 2000.
- [4] PARK, S., WOO, S., KIM, M. *et al.*: *Thermal modeling in an engine cooling system to control coolant flow for fuel consumption improvement*. Heat Mass Transfer **53**(2017), 4, 1479–1489. <https://doi.org/10.1007/s00231-016-1909-z> (accessed 15 Oct. 2018).
- [5] KNEBA Z.: *A Study of Waste Heat Management in Passenger Car Engines*. GUT Publishing House, Gdańsk 2011 (in Polish).
- [6] <https://community.plm.automation.siemens.com/t5/System-Simulation-Knowledge-Base/Top-10-analyses-to-run-with-Simcenter-Amesim-engine-models-and/ta-p/406592> (accessed 23 Sept. 2018).
- [7] CICHY M., KNEBA Z., KROPIWNICKI J.: *Causality in models of thermal processes in ship engine room with the use of bond graph (BG) method*. Pol. Marit. Res. **24**(2017), Spec. Iss. S1(93), 32–37.
- [8] RONKOWSKI M., KNEBA Z.: *Bond-graphs based modelling of hybrid energy systems with permanent magnet brushless machines*. Int. 15th Symp. Micromachines and Servosystems Electrotechnical Institute, Warsaw 2006, 312–319.
- [9] MIKIELEWICZ D.: *A new method for determination of flow boiling heat transfer coefficient in conventional-diameter channels and minichannels*. Heat Transfer Eng. **31**(2010), 276–287.
- [10] ŻMUDKA Z., POSTRZEDNIK S., PRZYBYŁA G.: *Realization of the Atkinson-Miller cycle in spark-ignition engine by means of the fully variable inlet valve control system*. Arch. Thermodyn. **35**(2014), 3, 191–205, DOI: 10.2478/aoter-2014-0029.

