

MODELLING AND ANALYSIS OF BEAM/BAR STRUCTURE BY APPLICATION OF BOND GRAPHS

CEZARY ORLIKOWSKI
RAFAŁ HEIN

*Gdansk University of Technology, Mechanical Engineering Department, Gdańsk, Poland
e-mail: corlikow@pg.gda.pl; rahe@pg.gda.pl*

The paper presents a uniform, port-based approach to modelling of beam/bar systems (trusses). The port-based model of such a distributed parameter system has been defined by application of the bond graph methodology and the distributed transfer function method (DTFM). The proposed method of modelling enables one to formulate input data for computer analysis by application of the DTFM. The constructed computational package enables frequency domain analysis. Additionally, the presented approach uses DTFM to obtain a modal reduced model of the considered system in the form of modal bond graph. The presented algorithm in a simply way allows one to obtain a modal reduced model of complex distributed-lumped parameter beam/bar systems.

Key words: mechanical system, modelling, modal analysis

1. Introduction

A typical mechatronic system consists of different domain subsystems. The model of the whole system should be closely related to the system structure and parameters. The port-based technique seems to be an appropriate approach for modelling of that kind of systems. One of the well known port-based techniques is the bond graph method (Amerongen *et al.*, 2000; Granda, 2002; Orlikowski, 2005). It is a diagram-based (graphical) tool used for description of physical systems and to predict their dynamic behaviour. Bond graphs modelling is based on energy flow and exchange. In this approach, the model of the whole system is constructed from its submodels by their straightforward interconnection. Models obtained in a such way are reusable and extendible. Such an approach is an especially convenient tool for modelling of multi-domain

complex mechatronic systems. It means that a system composed of different mechanical, electrical, pneumatic, hydraulic, thermal and other components can be simply and directly translated into unified description of the bond graph model. Bond graph notation contains all information about the system structure and mathematical description related to the investigated system.

In paper Orlikowski (2005) there is presented a uniform, port-based approach to modelling of both lumped and distributed parameter systems. The port-based model of a distributed system has been defined by application of the bond graph methodology and the distributed transfer function method (DTFM) (Yang and Tan, 1992; Yang, 1994). The approach proposed combines versatility of port-based modelling and accuracy of the distributed transfer function method. The concise representation of lumped-distributed systems has been obtained. The proposed method of modelling enables one to formulate input data for computer analysis by application of DTFM.

Distributed parameter systems are given in terms of partial differential equations. However, similar to lumped parameter systems, they can also be described by the transfer function method. In this case, the distributed transfer function is the corresponding mathematical model (Orlikowski *et al.*, 2009, Yang, 1994). It contains all information about the system and enables one to obtain the response under any excitation and to predict the system spectrum. The distributed transfer function method (DTFM) does not assume any approximation by lumping technique. Thus, the distributed parameter nature of the system is fully taken into account in a systematic way. This is especially important in modelling of mechanical systems for control/mechatronics purposes.

This paper presents the use of bond graph and DTFM method for modeling of beam/bar systems and trusses. The simple example illustrates application of the developed computer program for modelling and analysis of such systems. It is possible to analyse beam/bar systems in the frequency domain (frequency characteristics, eigenvalues, eigenfunctions, response to harmonic excitation) and to obtain a reduced-order modal model of the system. The modal model can be exported to *20-Sim* (Weustink *et al.*, 1998) software for further processing.

2. Modelling of beam/bar structure

In the method presented in Orlikowski (2005) distributed parameter subsystems of the whole complex system are defined (described) as multiport elements. In the distributed parameter multiport, some power ports are related



to boundary conditions, and some of them are related to external load. Power ports are places at which the subsystems can be interconnected and at which the power flows from one subsystem to another one. The power flowing into or out of a port can be expressed as the product of two variables ($e(t)$ – effort and $f(t)$ – flow). The general concept of the port-based model of a distributed parameter system is presented in Fig. 1.

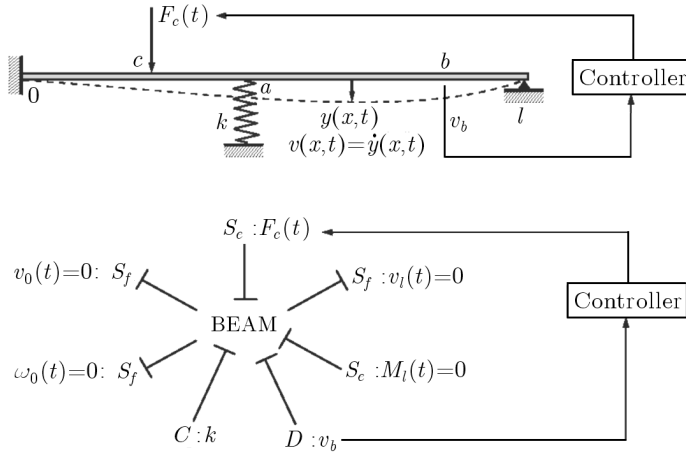

Fig. 1. General concept of the port-based model of a distributed parameter system (system and corresponding bond graph model)

The considered beam/bar systems are assumed to be composed of one-dimensional distributed parameter systems. For each element, there exist four possible displacements: longitudinal, transverse displacements in two perpendicular planes, torsional (see Fig. 2).

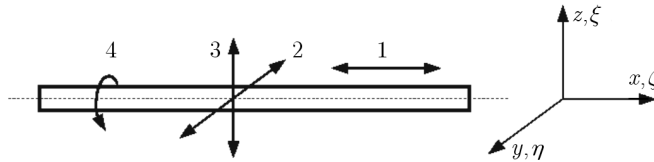

Fig. 2. Beam/bar element with four possible displacements: 1 – longitudinal, 2, 3 – transverse displacement in y and z direction, respectively, 4 – torsional displacement (yz -plane)

If the overall structure is composed of such elements, then the overall mathematical model can be formulated by application of partial differential equations (PDE) with appropriate boundary conditions dependent on external fixing and connections between the elements.

In the beam problem, two variables are related to each boundary point, i.e. at $x = 0$ and at $x = l$. Figure 3. presents the beam with exemplary boundary conditions, its partial differential equation (after Laplace's transformation with respect to time) and the corresponding bond graph representation. Figures 4 and 5 present mathematical and bond graph models of the bar with longitudinal and torsional displacement, respectively.

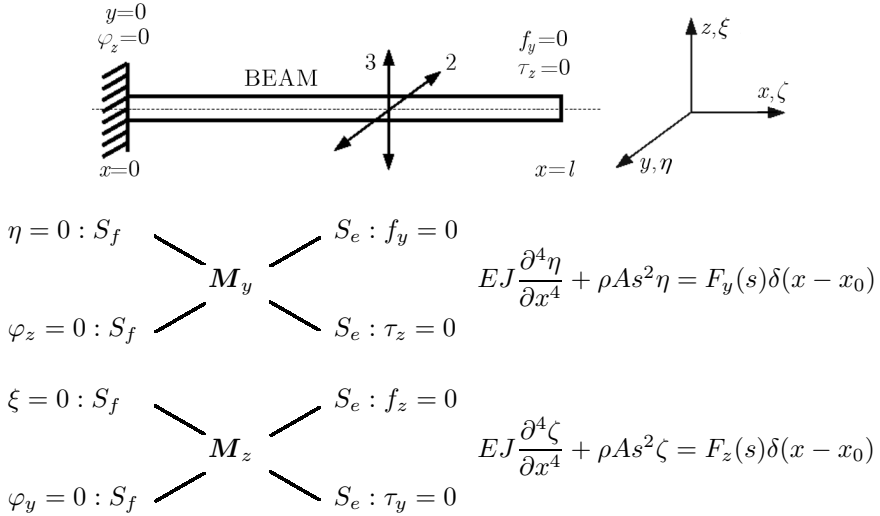
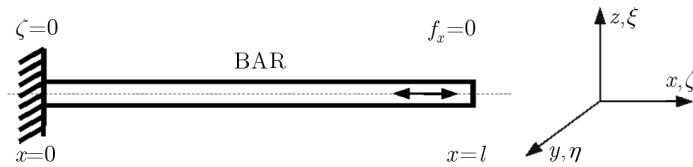

Fig. 3. Beam element with exemplary boundary conditions, corresponding equation and bond graph representation, M_y, M_z – multiport representing distributed parameter elements, ζ, η, ξ – displacements in x, y and z directions, respectively, f_y, f_z – forces, τ_y, τ_z – bending moment, s – Laplace operator, S_e, S_f – sources, E – Young modulus, J – moment of inertia, ρ – mass density, A – cross-sectional area, δ – Dirac delta

Figure 6 presents the part of a space truss (beam/bar structure) and its bond graph model in general form. The form of the junction structure depends on particular connections between elements.

3. Computer aided modelling of beam/bar systems by application of bond graphs

One of the main and most challenging steps in the analysis by application of DTFM is generation of a computer model. For this reason, a pre-processor has been developed in order to help creating of the model. The pre-processor is integrated with the *Mathematica* software as the simulation tool.



$$\zeta = 0 : S_f \text{ --- } M_x \text{ --- } S_e : f_x = 0 \quad \rho A s^2 \zeta - EA \frac{\partial^2 \zeta}{\partial x^2} = F_x(s) \delta(x - x_0)$$

Fig. 4. Bar element (longitudinal vibrations) with exemplary boundary conditions, corresponding equation and bond graph representation, M_x – multiport representing the distributed parameter element, ζ, η, ξ – displacements in x, y and z directions, respectively, f_x – force, s – Laplace operator, S_f – source, E – Young modulus, ρ – mass density, A – cross-sectional area, δ – Dirac delta



$$\varphi = 0 : S_f \text{ --- } M_{yz} \text{ --- } S_e : \tau_x = 0 \quad \rho J_0 s^2 \varphi - G J_0 \frac{\partial^2 \varphi}{\partial x^2} = M_x(s) \delta(x - x_0)$$

Fig. 5. Bar element (torsional vibrations) with exemplary boundary conditions, corresponding equation and bond graph representation, $M_{yz(\varphi)}$ – multiport representing the distributed parameter element, ζ, η, ξ – displacements in x, y and z directions, respectively, τ_x – torque, s – Laplace operator, S_f – source, E – Young modulus, J – moment of inertia, ρ – mass density, A – cross-sectional area, φ – angular displacement around x axis, δ – Dirac delta

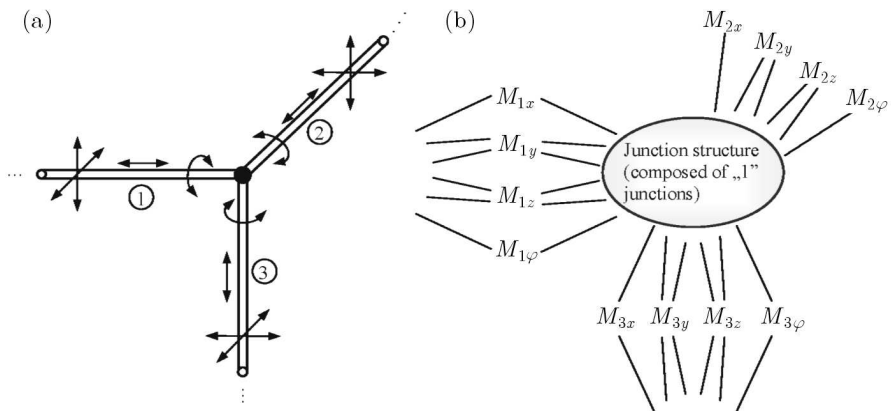

Fig. 6. Beam/bar structure (a) and its bond graph model in a general form (b)

The input data for analysis is presented in form of the bond graph model. The bond graph based approach allows the modelling of interdisciplinary and complex systems. Additionally, it enables one to automate the process of generation of the system equation related to DTFM methodology. Figure 7 shows accessible elements in the created bond graph editor, whereas Fig. 8 – exemplary beam/bar system and the corresponding bond graph.

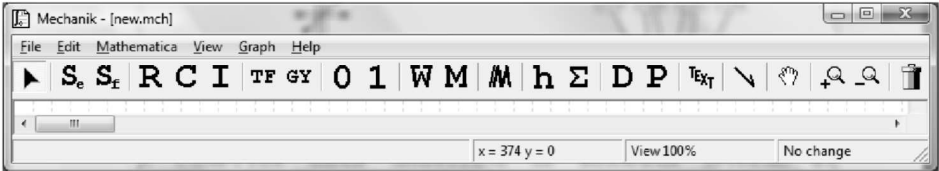

Fig. 7. Bond graph editor toolbar of the developed package: S – sources, D – detector, R , C , I – basic one-port elements, TF , GY – basic two-port elements, 0 , 1 – $0/1$ junctions, W – multiport element (lumped parameters), M – multiport element (distributed parameters), h – transfer function (signal transformation element)

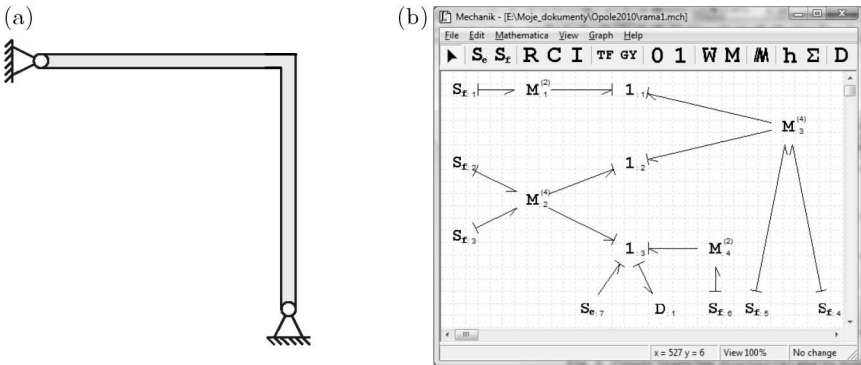

Fig. 8. Simple beam/bar structure (a) and its bond graph (b)

The developed computer modelling and analysis program enables one to obtain :

- system response to harmonic excitation,
- frequency characteristics,
- eigenvalues and eigenfunctions of the system,
- modal reduced model of the given complex distributed lumped parameter system.



The automatically generated reduced modal model has the form of a bond graph (modal bond graph). The obtained low-order model can be directly exported to the professional *20-Sim* package for further processing including nonlinear components and time domain analysis. It is worth to stress that *20-Sim* software has been designed for modelling and analysis of mechatronic systems.

4. Illustrative example 1 – distributed parameter model

For illustrative analysis, a plane framework is considered. The beam/bar structure consists of six rigidly connected elements (Fig. 9) with excitation P (force) and response y (displacement). The bond graph model of the system is presented in Fig. 10. The frequency characteristic (Fig. 11) has been obtained by application of the computer program described in Orlikowski *et al.* (2009).

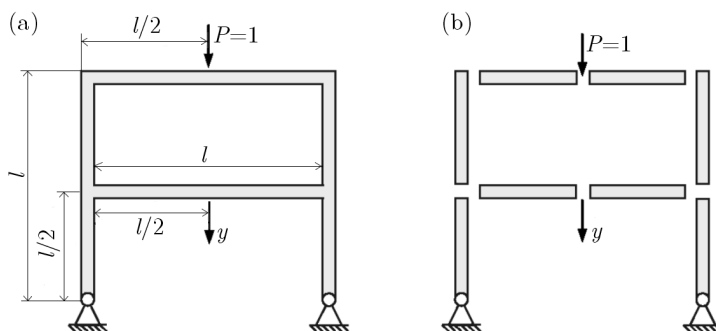

Fig. 9. Considered plane framework ($l = 2$ m, $b = 0.1$, $h = 0.1$, $A = bh = 0.01$, $E = 2.1 \cdot 10^{11}$, $\rho = 7850$, $J = 8.3 \cdot 10^{-6}$)

5. Reduced order model of beam/bar structure

Complexity of the model of a mechatronic system is a very important problem in the analysis and design procedure. It is especially strongly related to the spatially distributed mechanical systems. In order to obtain enough accuracy - large complex mathematical models are used for simulation and prediction. Distributed parameter models (described above, for example) or finite element models can be applied.

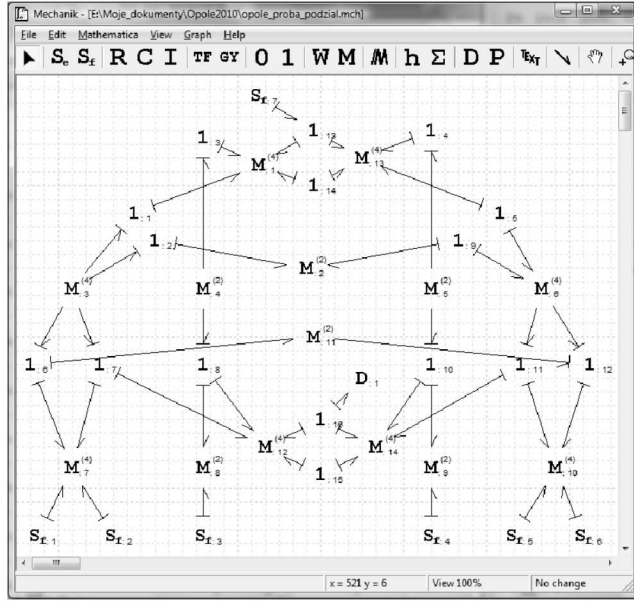

Fig. 10. Bond graph of the considered plane framework (from Fig. 9)

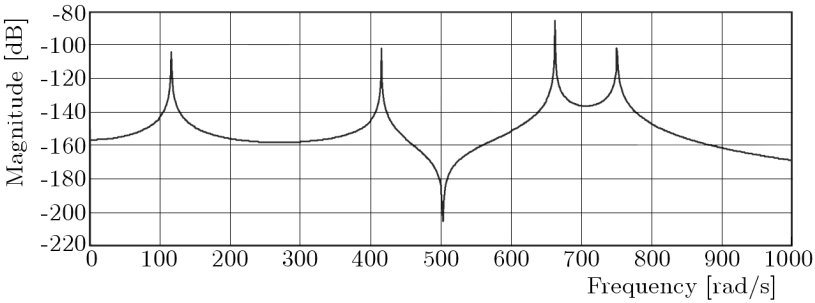

Fig. 11. Frequency characteristic obtained for the system from Fig. 9 by simulation of the bond graph model presented in Fig. 10

Using the finite element method, it is possible to obtain an enough accurate model and final results. However, the mesh size would become very small and finally the order of the model would become very high. In response analysis of large mechanical systems, the use of the complete high-order model results in considerable computer run time and huge storage requirements as well. An additional problem is that in control (mechatronic) systems design and analysis it is useful to work with simple, low-order models, because they are easier to



evaluate. To avoid such a problem, the model reduction by application of the modal truncation method is widely applied.

As mentioned above, the proposed computer program can be also used to obtain a reduced-order modal model of the given distributed parameter structure. Such a model can be next exported to *20-Sim* software for further processing. In this way, it is possible to add some nonlinear components and to perform time domain analysis. Additionally, it must be pointed out that application of low-order models is especially convenient in the analysis and design of control and mechatronic systems.

Figure 12 presents an example of a simple system and the corresponding model in form of a modal bond graph.

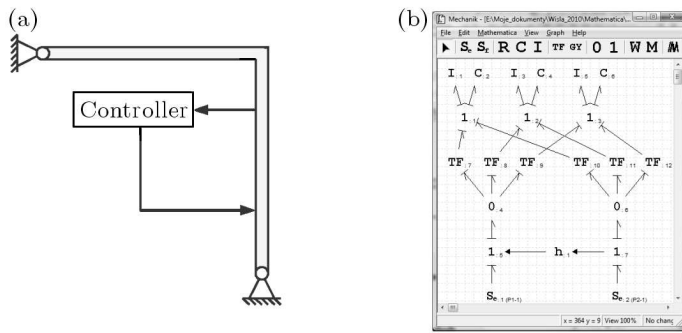

Fig. 12. Beam/bar structure (a) and its modal bond graph (b)

The investigated below example illustrates the use of the modal bond graph method for the modelling of beam/bar structures. The proposed approach has many advantages. Low order of the model and its high accuracy are most important of them. The obtained reduced model is exact in the frequency range related to the number of retained modes.

6. Illustrative example 2 – modal bond graph

The exemplary beam/bar structure and its bond graph representation is presented in Fig. 13. Figure 14 presents data input window for loading appropriate partial differential equations and its boundary conditions. Figures 15 and 16 present steps of the analysis of the considered beam/bar structure. The obtained results (eigenvalues and eigenfunctions) are necessary for modal model construction.



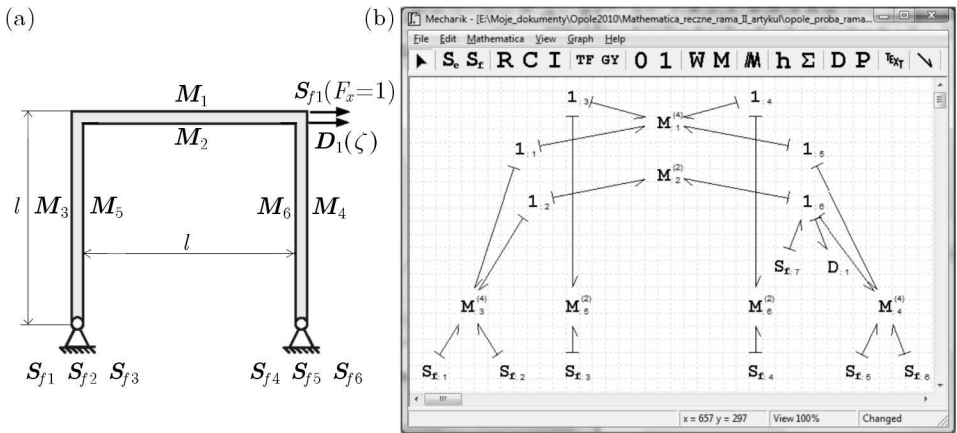

Fig. 13. Exemplary beam/bar structure and its bond graph representation
 ($l = 2 \text{ m}$, $b = 0.1$, $h = 0.1$, $A = bh = 0.01$, $E = 2.1 \cdot 10^{11}$, $\rho = 7850$,
 $J = 8.3 \cdot 10^{-6}$)

Element

Description: M

Bonds count: 4

Model order: Length L:

Parameters:

	w(IV)	w(III)	w(II)	w(I)	w
	EJ				$\rho \cdot A \cdot s^2$

Boundary conditions:

x	f	e			
x=0	\leftarrow	\rightarrow	EJ		$S_{x,1}$
x=0	\leftarrow	\rightarrow		EJ	$S_{x,2}$
x=L	\leftarrow	\rightarrow	EJ		$1_{,2}$
x=L	\leftarrow	\rightarrow		EJ	$1_{,1}$

Fig. 14. Data input window for loading appropriate partial differential equations and their boundary conditions

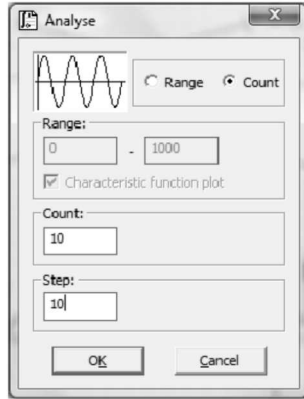

- $\omega_1 = 102.4921$
- $\omega_2 = 475.5440$
- $\omega_3 = 687.3791$
- $\omega_4 = 835.1297$
- $\omega_5 = 900.4844$
- $\omega_6 = 1646.6756$
- $\omega_7 = 2150.1101$
- $\omega_8 = 2228.2730$
- $\omega_9 = 2302.0675$
- $\omega_{10} = 3226.1181$

Fig. 15. Data input window for choosing the number of calculated eigenvalues and the obtained results (eigenvalues of the considered system)

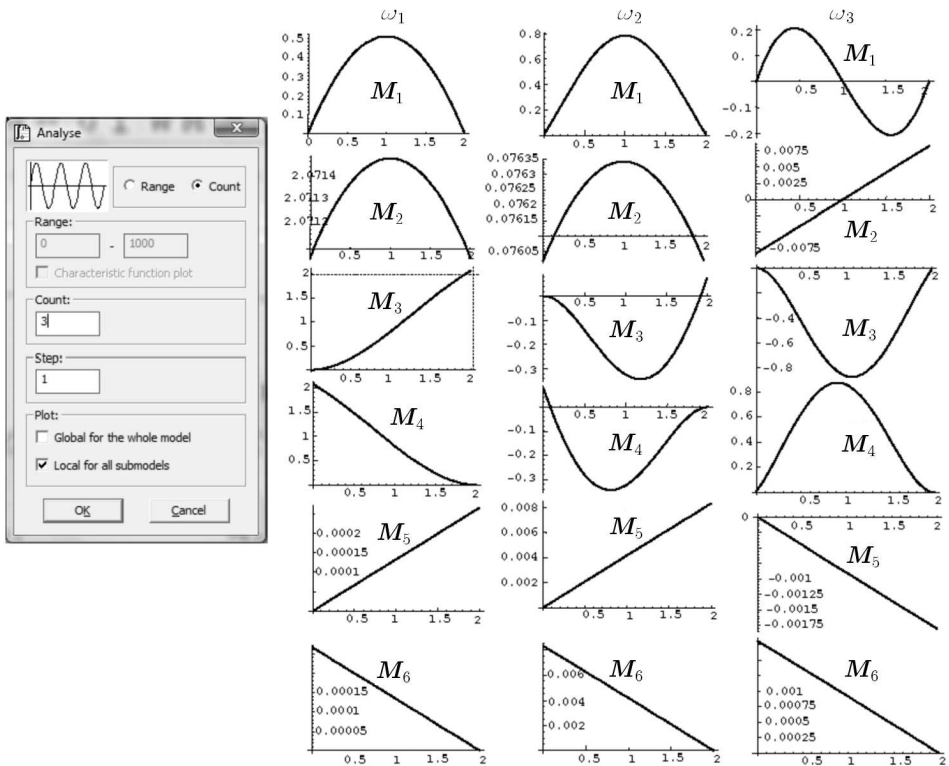

Fig. 16. Data input window for choosing the number of calculated eigenfunctions and the obtained results (eigenfunctions of the considered system)

The reduced modal model must contain an appropriate number of power ports needed to establish the system inputs and outputs or to connect other submodels (nonlinear elements, non-proportional damping, controllers etc.). Figure 17 presents the defining of modal bond graph power ports. Obtained modal bond graph related to the structure from Fig. 13 is presented in Fig. 18. The graph has been obtained for three retained modes and it has one power port for the input/output signals.

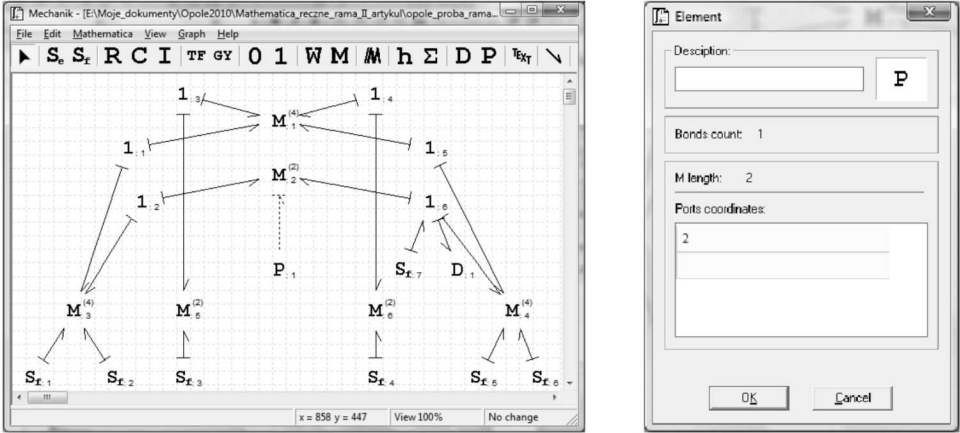

Fig. 17. Definition of power ports P related to the modal bond graph

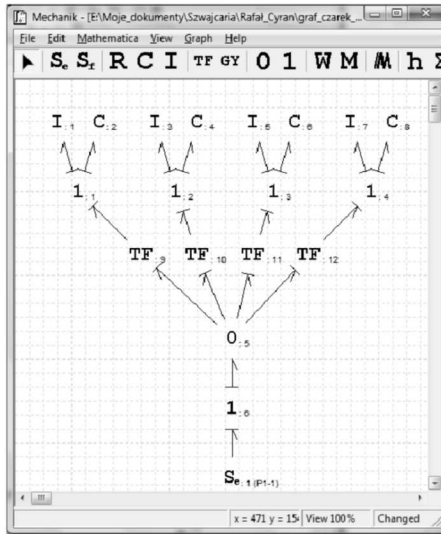

Fig. 18. The obtained modal bond graph (with three modes retained and with one power port for input/output signals) of the structure from Fig. 13



In order to validate the obtained reduced model frequency characteristics of the reduced model (Fig. 18) and non-reduced model (Fig. 13b) have been compared – see Fig. 19. The frequency characteristics are calculated for the input signal acting at the point presented in Fig. 13a. The displacement output signal is observed at the same point. From Fig. 19, one can see that in the range of frequency related to the number of retained modes, the frequency responses for the reduced model have the same shape as for the reference model.

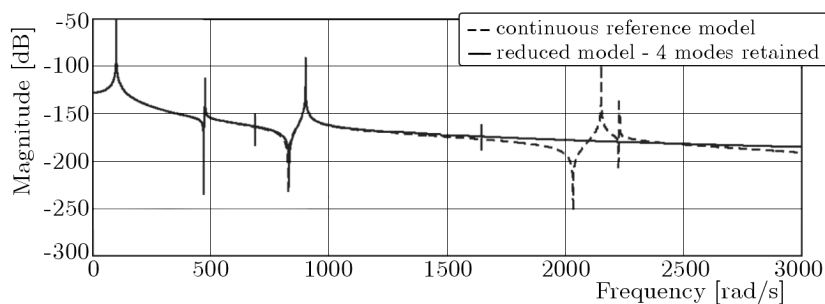

Fig. 19. Frequency response for the reduced and non-reduced models

7. Summary

The presented method explores the bond graph technique as the modelling tool to generate mathematical models of complex beam/bar systems. It enables modelling of such systems by application of the bond graphs methodology and the DTFM algorithm. The developed computer program enables analysis of the frequency domain of a class of linear systems and obtaining a reduced-order model in form of a bond graph. The obtained modal bond graph can be directly exported into *20-Sim* package for further processing including nonlinear components, control devices (Fig. 20) and time domain analysis. In future works, active vibration control of complex beam/bar systems (Fig. 20) will be investigated by application of the created method of modelling. The proposed method can help analysis of multi-domain mechatronic systems. A special computer program has been developed. The presented approach combines advantages of the port-based modelling and the accuracy of the distributed transfer function method. Computer simulations and numerical calculations proved that the proposed method is efficient and can be applied for other, more complex systems.

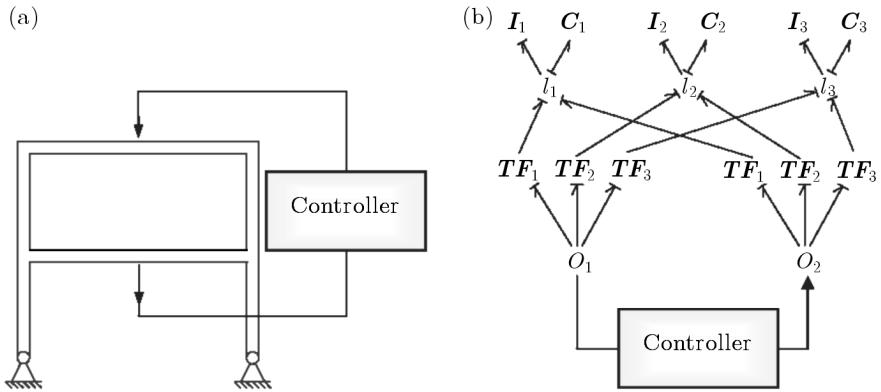

Fig. 20. Investigated system and its modal bond graph

Acknowledgements The research is supported from the science budget resources in 2008-2010 as the research project (NN 519404334).

References

1. AMERONGEN J., COELINGH E., VRIES T., 2000, Computer support for mechatronic control system design, *Robotics and Autonomous Systems*, **30**
2. GRANDA J.J., 2002, The role of bond graph modeling and simulation in mechatronics systems. An integrated software tool: CAMP-G, MATLAB-SIMULINK, *Mechatronics*, **12**
3. ORLIKOWSKI C., 2005, *Modelling Analysis and Synthesis of Dynamic Systems by Application of Bond Graphs*, Wyd. PG, Gdańsk, Seria Monografie, 55 [in Polish]
4. ORLIKOWSKI C., HEIN R., CYRAN R., 2009, Computational algorithm for the analysis of mechatronic systems with distributed parameter elements, *Projektowanie Mechatroniczne. Zagadnienia wybrane*, Kat. Robotyki i Mechatroniki AGH, Kraków, Wydawnictwo Instytutu Technologii Eksploatacji Państwowego Instytutu Badawczego (PiB), Radom
5. WEUSTINK P.B.T., VRIES T.J.A., BREEDVELD P.C., 1998, *Object-Oriented Modeling and Simulation of Mechatronic Systems with 20-sim 3.0*, Elsevier Science Ltd.
6. YANG B., 1994, Distributed transfer function analysis of complex distributed parameter systems, *ASME Journal of Applied Mechanics*, **61**, 84-92

7. YANG B., TAN C.A., 1992, Transfer functions of one-dimensional distributed parameter systems, *ASME Journal of Applied Mechanics*, **59**, 1009-1014

Modelowanie i analiza konstrukcji belkowo-prętowych z zastosowaniem grafów wiązań

Streszczenie

W pracy przedstawiono jednolity sposób modelowania konstrukcji belkowo-prętowych (kratownice). Model rozważanego systemu o parametrach rozłożonych został opracowany przy zastosowaniu metodologii grafów wiązań i metody transmitancji układów o parametrach rozłożonych (DTFM). Proponowana metoda modelowania pozwala sformułować wygodny algorytm do analizy komputerowej z zastosowaniem DTFM. Opracowany system obliczeniowy umożliwia analizę w dziedzinie częstotliwości oraz otrzymanie zredukowanego modelu modalnego rozważanego układu w postaci modalnego grafu wiązań. Prezentowany algorytm w prosty sposób pozwala na uzyskanie zredukowanego modelu modalnego złożonych, dyskretno-ciągłych układów belkowo-prętowych.

Manuscript received October 4, 2010; accepted for print December 16, 2010

