

# MONITORING THE GAS TURBINE START-UP PHASE ON A PLATFORM USING A HIERARCHICAL MODEL BASED ON MULTI-LAYER PERCEPTRON NETWORKS

Tacjana Niksa-Rynkiewicz\* 

Anna Witkowska 

Jerzy Głuch 

Gdansk University of Technology, Poland

Marcin Adamowicz

Poland

\* Corresponding author: [tacjana.niksa@pg.edu.pl](mailto:tacjana.niksa@pg.edu.pl) (T. Niksa-Rynkiewicz)

## ABSTRACT

Very often, the operation of diagnostic systems is related to the evaluation of process functionality, where the diagnostics is carried out using reference models prepared on the basis of the process description in the nominal state. The main goal of the work is to develop a hierarchical gas turbine reference model for the estimation of start-up parameters based on multi-layer perceptron neural networks. A functional decomposition of the gas turbine start-up process was proposed, enabling a modular analysis of selected parameters of the process. Real data sets obtained from observations of the turbo-generator set located on a North Sea platform were used.

**Keywords:** industrial gas turbine; start-up monitoring; artificial neural network; hierarchical system

## INTRODUCTION

Gas turbine (GT) diagnostics is a complex task due to its dynamic nature and nonlinear performance characteristics, which makes it a difficult exercise that is therefore studied by many researchers. GTs are the basic type of turbines used in power industry systems. Effectiveness of their operation is fundamental [1-2]. A GT should ensure safe, reliable, fast and flexible operation also in transient states, i.e., during the start-up phase. Classical diagnosis methods compare observed measurement against a fixed threshold. The new proposed method allows more accurate monitoring, closer to the operating point, by comparing the predicted and observed measurements. This system is presented in Fig. 1.

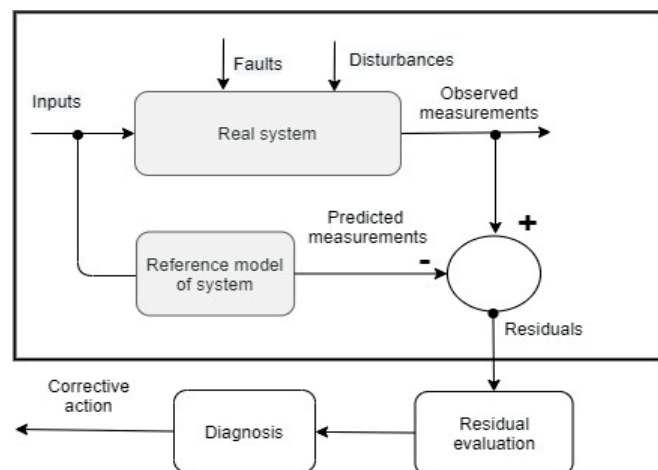

Fig. 1. Scheme of the system of residual generation

The main goal of the research is to build and analyse a reference model of the correct start-up of the *GT* and its decomposition. The article presents the hierarchical architecture of such a model and a method of estimating selected parameters using neural networks modules. Moreover, it was assumed that the developed reference model would be based on the simplest possible structure of the neural network, utilizing a minimum number of inputs in order to reduce the computational complexity of the neural network learning algorithm.

Computational models for the diagnosis and forecasting of *GT* operation during the start-up phase pose particular difficulties, because it is a high-power device and physical phenomena occur that are extremely non-stationary and often exceed load limits [3]. Therefore, changes in the turbine start-up parameters should be monitored to determine the causes of faults that prevent the *GT* from starting properly. The literature often emphasizes the benefits of having a reference model of the system (*RMS*) of the *GT* start-up. This article is focused on this issue.

In future research, the results from the *RMS* can be used to diagnose a failed *GT* start-up, help to assess the *GT*'s technical condition, and predict its future failures. The paper presents the model architecture and the method for estimating the specified parameters. Measurements obtained from experimental trials on a chosen machine are used to demonstrate that the proposed approach is practical and useful. The results confirm the effectiveness of the proposed model.

## RESEARCH GOAL

The aim of the article is to present the method of creating a reference model for the proper launch of a *GT*. After observing the *GT* start-up, the process was decomposed, taking into account only selected parameters for estimation. These are the parameters of the *GT* control system: guide vane command (*GV\_C*); bleed valve command (*BV\_C*), pressure compressor discharge (*PCD*); normalized power turbine speed (*NPT*); fuel control valve command (*FCV\_C*); fuel valve differential pressure (*FV\_DP*); and inlet air filter differential pressure (*IAF\_DP*). These selected process parameters finally affect the *FCV\_C*. Safety parameters were not considered in the deliberations.

The start-up of a modern power plant *GT* is carried out with a procedure popularly called "one button" and lasts from several dozen seconds to 2-3 minutes depending on the turbine size and application. The automatic procedure adapts the start-up phases to the current environmental conditions. Moreover, the values of the parameters of individual start-up phases depend on the quality of operation of individual component devices of the power unit. In most cases, the start-up of the machine is successful.

However, there are situations of unsuccessful starting and stopping of the machine in different phases of the start-up. The engineer-operator is then tasked with finding the root

cause and resolving it. For this purpose, he needs a correct start-up pattern, which shows not only the final start-up effect (the correct operation of the entire machine), but also the processes of achieving the parameters that end individual start-up phases and obtaining a "permit" to move to the next phase. The final phase consists in fuel valve control, which is very important not only for the start-up but also for normal sea operation [4]. Failure to achieve the correct values of these parameters in any phase causes the start-up procedure to stop. This failure is noticed as a difference (residual) between the current measured values and the correct values that exceeds the limit. The engineer-operator should indicate the causes of failure based on the analysis of differences in the residuals. The lack of a pattern of the correct path of the boot-up parameters makes it difficult and sometimes impossible to find differences and to explain the reasons for the collapse in the start-up strategy.

Comparison between corresponding measured and pattern values is the basis for further analysis of the time-dependent parameter trends of the machine start-up phases. For the purpose of this analysis, the authors have decided to apply the methods of artificial neural networks.

This model is composed of a proper simple individual start-up phase neural model to ensure a universal modular base start-up model. In order to apply it to any other specific turbine it is necessary only to update the neural modules or its structure. This is an advantage of the proposed pattern modular configuration.

## RELATED WORKS

For industrial gas turbine (*IGT*) systems, classical (stationary or non-stationary) dynamic models described by state variables are difficult to obtain. They usually do not fully capture the detailed physical characteristics of the start-up operations due to the complexity of the structure, auxiliary equipment and control system. Linearization methods and laws of physics, principles of thermodynamics, and energy balance equations are used in constructing *IGT* dynamic models [3, 5-7]. However, this process is time-consuming and limited to specific ranges of operating and environmental conditions [8].

Artificial intelligence methods have been widely used in the simulation and modelling of industrial systems [9]. They provide an alternative to classic computational methods. The black-box models, such as artificial neural networks (*ANN*), are widely used to predict and monitor the dynamics of industrial equipment and systems due to their nonlinear and non-parametric properties [10-11].

The *ANN* provides an appropriate solution in situations where data are characterized by irregularity and diversity caused, for example, by external exogenous factors. They are able to learn patterns while acquiring the ability to generalize knowledge. There are many works using different *ANN* architectures for computer-based *GT* models during start-up operations. These can be multi-layer perceptron (*MLP*) [12],

recurrent neural network (*RNN*), deep neural network (*DNN*), radial basis function (*RBF*), nonlinear auto-regressive moving average with exogenous inputs (*NARMAX*), and nonlinear autoregressive exogenous models (*NARX*) [13]. A review of existing solutions applied to *GT* performance diagnosis and prediction can be found in the work [14]. The authors of the paper emphasize that the proposed models are satisfactorily able to capture the system dynamics during *GT* start-up operations and predict its behaviour. However, the conventional *ANN* methodology provides limited insight into the physical phenomena of the system under different operating conditions, and is consequently not robust to uncertainties. Therefore, hybrid versions of *ANN* and other systems, such as fuzzy systems, are often used. A combination of the adaptive neuro-fuzzy inference system (*ANFIS*) allows one to benefit from both fuzzy rules - e.g., expert knowledge about known input or output distributions - and *ANN* for nonlinear and nonparametric estimation [15-16].

There are methods based on creating a graphical representation of the physical system, such as the bond graph [17]. This graphical representation increases one's insight into systems behaviour and understanding of the energy transfer between the inner components. The authors present the benefits and the results confirm the effectiveness of the proposed approach in detailed performance prediction of the *GT* in the start-up phase. The paper [18] addresses the problem of estimating the internal parameters of a *GT*, such as the temperature in the combustion chamber, using a neural network. This is a very important parameter that was used in the control system. The results show that the neural network estimates this parameter much more accurately than the available method using nonlinear equations.

Neural networks as a tool for the prediction of technical conditions are shown as a novel solution [19-20], which allows not only the isolation of known anomalies, but also the detection of previously unobserved events. The authors of [21] propose to use this feature for an advanced condition monitoring system for a *GT*. As well as monitoring known anomalies (e.g., tracking actuator position discrepancies), it also tracks previously unobserved states (e.g., a spike in the pressure reading from a compressor at a constant machine load).

The problem of predicting the compressor characteristics of the turbine-generator system was discussed in [22]. Much attention was paid to the dynamic states of the system, in which the compressor steering wheel control affects the operation of the entire machine. The equations describing the system model are solved numerically and the results are compared with actual readings from the object. The use of an *ANN* to build a machine efficiency model was proposed in the work [23], with the exception that accurate estimation is only possible in a narrow range of operation and to extend this range more networks should be used.

In this particular work, it is theorized that it is most beneficial to train neural networks that perform more functions rather than a single one that attempts to perform all tasks, such as efficiency assessment, fault detection or

prediction. The effectiveness of the estimation methods using *ANN* depends on the accuracy, quantity and quality of the training sets. These data can be determined from physical models or obtained experimentally.

## MOTIVATIONS

The following considerations motivated the approach proposed in this work:

- the need to diagnose the technical condition of the *GT* and the wear and tear of the equipment,
- extending the classic diagnosis online methods to new bespoke fault models,
- the need to diagnose unsuccessful *GT* start-ups,
- the need to monitor the *GT* start-up system,
- the existing algorithms are insufficient and there is a need to find new solutions, as the problem is still relevant,
- the complexity of the processes occurring in the start-up phase is so great that the use of classical computational models is burdened with large modelling errors,
- simple solutions are needed that can be easily implemented in *IGTs* running in real time.

Existing solutions based on deep or recurrent networks are more complex and labour-intensive for industrial implementation.

## NOVEL ELEMENTS

The novel elements of the proposed approach can be summarized as follows:

- designing a hierarchical architecture for the *IGT* reference start-up model using *ANN*,
- decomposition of the *GT* start-up process into the sets of primary and secondary parameters,
- the proposed model is functional, gives the possibility of easy adaptation in case of changing the type of fuel (liquid, volatile) and using a different type of turbine (e.g., *DLN*, single shaft, compressor set),
- the designing of individual neural modules (estimators of selected parameters) and training them with a raw data set obtained in the start-up phase, during the normal state of *GT* operation,
- the designing of a model which can be easily extended with further modules for the estimation of additional parameters of the system,
- the modularity of the proposed system provides easy relocation of the modules. Non-modular design would not be easy to adapt when there is a need to change system components,
- the modularity of the architecture facilitates implementation in *IGT*.



## DESCRIPTION OF GAS TURBINE AND ITS START-UP PROCESS

The turbine generator described here has available power of 11.350 kW<sub>e</sub> (at 15°C ambient temperature and placed at sea level). It is a twin-shaft engine. It has an annular combustion chamber with 21 conventional fuel injectors and a single touch ignitor. The normalized gas producer speed (*NGP*) at 100% is 8983 rpm and the power turbine (*PTr*) 8568 rpm. The *PTr* is mechanically coupled with a generator via an epicyclic reduction drive gearbox of 1800 rpm, thus providing a 4.76:1 speed reduction ratio. The engine is equipped with an electrical starter motor that has variable speed control. The starter aids the gas producer speed acceleration up to 65%, when it reaches self-sustainable speed and the automatic clutch is disengaged between the two.

Data was collected from an engine that has around 15,000 operating hours and a time between overhauls of around 30,000 hours. A typical engine compressor wash is carried out annually unless a significant loss of its performance is seen. This engine has a high flow, low pressure lube oil system. It has variable header pressure that depends on the engine compressor speed (this is to prevent ingress of oil from bearings into the engine). At idle speed, the pressure of the lube oil is set around 340 kPa and the temperature to 50°C. A diagram of the research object with the most important components is shown in Fig. 2.

During the start-up process, the commands of individual actuators (*BV\_C*, *GV\_C*, *FCV\_C*) as well as the measurement states (*NPT*, *PTIT*, *NGP*, *PCD*, *FV\_OP*, *IAT*) change (Fig. 2). The state of the bleed valve (*BV*) opening at *GT* start-up determines the amount that enters the combustion chamber, the machine start-up characteristics and other derived states. The set *BV\_C* value at the initial stage influences the process of closing the bleed valve to prevent surge in the compressor and *PTr*. The position of the *BV\_C* valve depends on the *NGP* speed and the *IAT* temperature. The value of the closing state is inversely proportional to this measurement. Another actuator whose function is adjustable during the start-up phase is the variable guide vane (*GV*). Its position is fully closed, thus limiting the flow through the compressor as much as possible.

The *GV\_C* controls the first four of the six stages of the compressor *GV* via a single actuator. Its position depends on the *NGP* and inlet air temperature (*IAT*) schedule map. After the *NGP* exceeds 80% of the set-point, the *GV\_C* starts to open the actuator position. The *GV* position will also have an offset associated with the *IAT*. The *GV\_C* will reach 100% at maximum engine power.

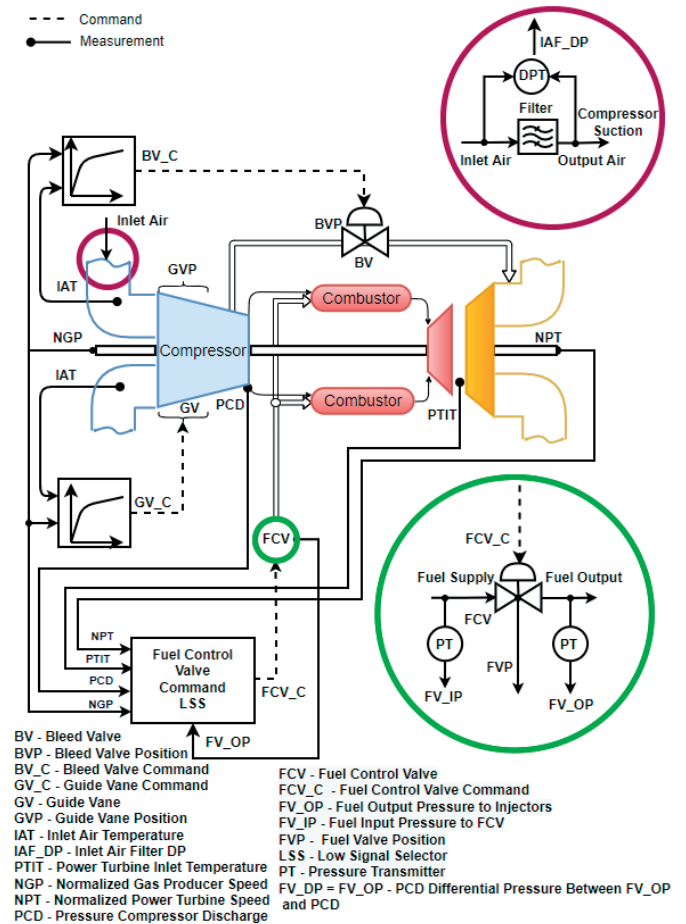

Fig. 2. Diagram of the research object with the most important components

The operation of the fuel control valve (*FCV*) is controlled by a low signal selector (*LSS*) type controller by selecting the smallest deviation value of the *NPT* and *NGP* and the maximum acceleration rate signals; the fuel output pressure to *PCD* pressure (*FV\_OP* to *PCD*) control limits the fuel to compressed air ratio and the maximum combustion chamber temperature, which is limited based on an indirect *PTr* inlet temperature (*PTIT*) measurement. The *NGP* is a measured value and has a direct impact on the control of the entire turbine. The *FCV*, *GV* and *BV* values are reflected in the condition of the system (vibration level, compressor pressure - *PCD*). Another parameter that determines the available power of the *GT* unit is the pressure from the compressor (*PCD*). This is the discharge pressure of the 15-stage compressor with a pressure ratio of 17.8:1 raising the atmospheric air temperature to 400°C at full power.

As can be seen from the analysis presented in this section, the set of the *BV\_C* in the system plays a significant role for the state of the other parameters. The position of the *GV\_C* mainly depends on the compensated *NGP* speed. The *NPT* velocity is crucial for the generation unit, as its value after start-up must be at a fixed value of 100%. Graphs of the changes in the values of the discussed parameters during *GT* start-up are presented in Fig. 3.

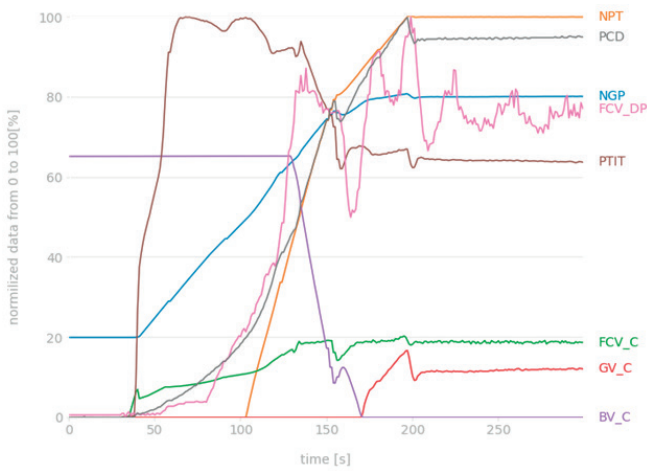

Fig. 3. Selected parameters changes during the GT start-up

For evaluating the compressor condition in the analysed system, the *PCD* parameter is a very important attribute. It determines the available power of the generation unit. A parameter strongly related to the *PCD* is the *IAF\_DP*. It describes the condition of the filter, which depends on the *IAT*, humidity, *PCD*, *NGP*, inlet filter condition, air pollution and operating hours of the engine. The *FV\_DP* is the last parameter in the hierarchy. When combined with the fuel valve input pressure (*FV\_IP*) value, the amount of fuel consumed by the engine can be evaluated.

## DESCRIPTION OF THE PROPOSED APPROACH

On the basis of the analysis of the turbine performance together with the start-up control system, the 7 most significant parameters of the estimation process can be

distinguished: *GV\_C*, *BV\_C*, *NPT*, *FV\_DP*, *IAF\_DP*, *FCV\_C*, *PCD*, and these parameters were used to build the reference model of the system (Fig. 4).

A hierarchical reference model architecture is proposed. The architecture of such a system is the result of the decomposition of the *GT* start-up parameters estimation system into a set of hierarchically connected individual estimators. First, the primary parameters are estimated, such as the *GV\_C* and *BV\_C*. These are parameters whose inputs are only raw readings from the engine. The estimation of primary parameters is realized by the higher set of modules in the hierarchy called primary estimators (Fig. 4). The remaining necessary parameters are estimated in a set of lower hierarchy modules, here called secondary estimators. The secondary estimation process covered parameters depending on the value of the primary estimates: *NPT*; *FV\_DP*; *IAF\_DP*; *FCV\_C*; *PCD*. They use real input signals (measurements from package), outputs from primary modules or the signals highest in the hierarchy such as the fuel valve inlet pressure (*FV\_IP*), *NGP*, *IAT*, and *PTIT* inlet temperature (*PTIT*). Outputs from the *AIF\_DP*, *FCV\_DP* and all the other start-up parameters are available for predicting their value during the *GT* start-up to provide a new means of estimating the expected value vs the actual from the machine. The dotted green lines show the inputs to the secondary estimators that can use some inputs estimated by the primary estimator instead of reading these parameters from the *GT*.

The function of individual estimators, in both the primary and secondary layers, is performed by *MLP* type neural modules. The choice of system architecture was dictated by the analysis of the *GT* start-up system presented in section 2. A modular system approach allows for easy expansion, e.g., by adding more neural modules depending on the machine type and specific application. Each module in the hierarchical structure was modelled using an *MLP* network. All the implemented neural networks consisted of 4 hidden layers.

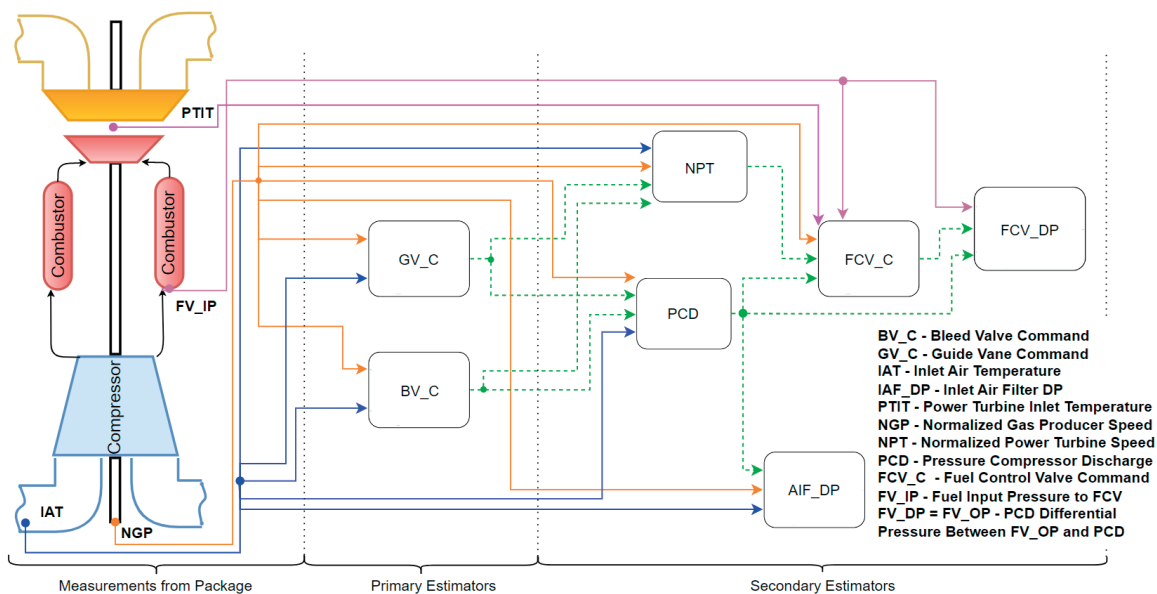

Fig. 4. Diagram of hierarchical reference model of system (continuous lines - readings from IGT, dashed lines - readings estimated by ANN)

An algorithm analogous to the back-propagation algorithm with the AdaGrad optimizer [24] was used to train the network. The network architecture in each module differed in the number of neurons. The  $M$  parameter is equal to the number of the inputs to each network.  $N$ ,  $D$  and  $P$  equate to the numbers of neurons in consecutive hidden layers. The initial values of the weights are represented by the  $w_i = [w_1 \dots w_M]$  vector and were chosen randomly. The output signal can be expressed by the following equation:

$$y_{out}(\mathbf{x}, \mathbf{w}) = \sum_{i=1}^P w_{out}^i f \left( \sum_{k=1}^D w_{ik}^{III} f \left( \sum_{j=1}^N w_{kj}^{II} h \left( \sum_{i=1}^M w_{ji}^I x_i + w_{j0}^I \right) + w_{k0}^{II} \right) + w_{i0}^{III} \right) + w_{out0}^i$$

The activation functions were selected as LeakyReLU  $f(x)$  and  $\tanh h(x)$ .

Training error was calculated as per the following equation:

$$E_u = \frac{1}{n} \sum_{i=1}^n (y_i - y_{wyj}(x_i, \mathbf{w}))^2$$

where  $i = 1, \dots, n$  is the number of output samples (sample output).

Tab. 1. Neural networks configuration

Name	Hidden Layer (I)	Hidden Layer (II)	Hidden Layer (III)	Estimated Output
FA	tanh	leaky_relu	leaky_relu	
No. of neurons	20	20	20	Guide Vane Command
	20	20	20	Bleed Valve Command
	50	50	50	Normalized Power Turbine Speed
	50	50	50	Pressure Discharge Compressor
	50	50	50	Fuel Valve Differential Pressure
	50	50	50	Fuel Valve Command
	50	50	50	Inlet Air Filter Differential Pressure

## SIMULATION

In the first stage of the research, neural modules were designed to estimate the system parameters. The neural modules were trained independently, using real measurement data read from the GT start-up system (Fig. 2) during its correct operation under normal conditions. Specially prepared sets of time series (200 samples with a 1-second resolution) were fed to the network inputs.

After that, the modules (the trained networks) were combined into a hierarchical modular neural reference model to form a complete system (Fig. 4). The testing was performed for the whole system. This means that, first, the parameters were estimated in the set of modules of higher hierarchy (primary), and then the obtained values of the estimates served as inputs in the set of modules of lower hierarchy (secondary).

Selected variants for different compressor  $IATs$  are presented because this had the strongest effect on the characteristics. The inlet temperature ranges are typical for winter ambient conditions in the North Sea when the data was collected. Examples of  $GT$  parameter time courses during the neural module training phase are presented in

Fig. 5. The solid line shows the actual run, the dashed line the estimated run.

After this first stage of the research, in the second step, the modules were combined into a hierarchical modular neural reference model to form a complete system (Fig. 4).

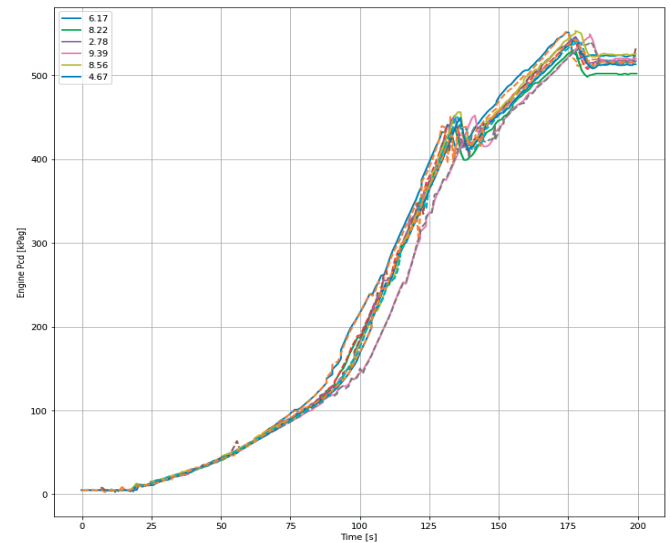

a) PCD

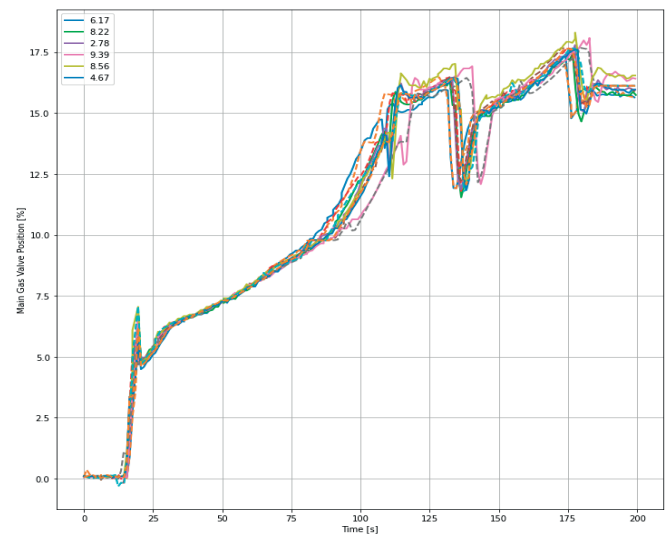

b) FVC\_C

Fig. 5. Plots of predicted (solid line) and estimated (dashed line) data

It can be observed for the selected two parameters in Fig. 5 that the ANN can predict complex parameters such as the  $PCD$  and  $FVC\_C$  (secondary estimators with at least 4 inputs) with a good accuracy. This could be attributed to the number of the training samples and intentionally narrow range of the  $IAT$  that was utilized to carry out the training and test. Some of the estimated trends deviate from the expected value, but this could be due to measurement error in the data set, too low resolution of the measurement or insufficient training data sets.

The system adjusted to different temperatures. The estimation proceeded correctly. The averaged training mean

square error was smallest for the  $GV\_C$  and  $BV\_C$  (order of  $10^{-2}$ ). The largest mean square error was obtained for the  $FCV\_C$  (order of  $2 \cdot 10^{-1}$ ). Additionally, the model was tested in predicting all the designed parameters as per Fig. 6. The dashed line denotes the estimated data, the solid line the measured values analogous to previous plots (Fig. 5).

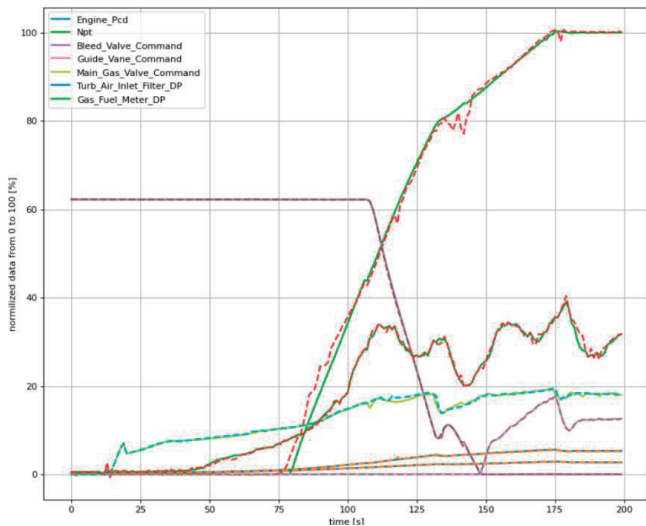

Fig. 6. Plots of predicted (dashed line) and test (solid line) data

The error values obtained during the process of training and testing of the neural networks estimating primary parameters were comparable. However, in the case of secondary parameters, there was a noticeable difference, and for these parameters, slightly higher error values were obtained. This is due to the accumulation of errors in the modular structure. The availability of a wide range of input compressor  $IATs$  for the training data could increase the robustness of the system to disturbances. This would allow better estimation of the outputs for the experimental states.

## CONCLUSIONS

As shown in the paper, the authors adopted the principle of the modular structure of the  $GT$  start-up model. Individual modules have been designed to model the control of the value of working agent parameters at individual start-up phases. Their functions are similar to those of the controllers of the real machine. They are also responsible for the correct sequence of transition to subsequent phases, which explains why the model proposed by the authors must have a hierarchical structure. This ensures the creation of a universal modular base start-up model. In order to apply it to any other specific turbine, it is necessary only to update the neural modules or its structure. This is a novelty and advantage of the proposed pattern of the modular configuration.

The individual modules developed make direct use of the measurement data and outputs of the primary modules. The results prove that the modular  $GT$  start-up model can be easily used and gives good accuracy of neural calculation.

At the same time, the modular system can be easily adapted to other types of power plant  $GTs$  and is more flexible in design and use. The designed system correctly estimates the start-up parameters of the  $GT$ .

The obtained observations can help the operator monitor, locate the fault approximately, and take basic corrective action (continue operation, change parameters, report an alarm to the operator, schedule service, or emergency stop the machine) or decide to restart after the necessary delay. However, using a start-up model to fully identify and isolate turbine faults requires additional work to expand the reference system and the availability of experimental start-up models with confirmed faults, which will be a further stage of the research.

## REFERENCES

1. O. Cherednichenko, S. Serbin, and M. Dzida, "Application of Thermo-chemical Technologies for Conversion of Associated Gas in Diesel-Gas Turbine Installations for Oil and Gas Floating Units," *Polish Marit. Res.*, vol. 26, no. 3, 2019, doi: 10.2478/pomr-2019-0059.
2. S. Serbin, K. Burunsuz, M. Dzida, J. Kowalski, and D. Chen, "Investigation of ecological parameters of a gas turbine combustion chamber with steam injection for the floating production, storage, and offloading vessel," *Int. J. Energy Environ. Eng.*, 2021, doi: 10.1007/s40095-021-00433-w.
3. V. Panov, "GasTurbolib-Simulink Library for Gas Turbine Engine Modelling", *Proceedings of ASME Turbo Expo 2009, GT2009*, June 8-12, Orlando, Florida, USA, 2009, doi.org/10.1115/GT2009-59389.
4. S. Serbin, N. Washchilenko, M. Dzida, and J. Kowalski, "Parametric analysis of the efficiency of the combined gas-steam turbine unit of a hybrid cycle for the FPSO vessel", *Polish Marit. Res.*, vol. 28, no. 4, 2022, doi: 10.2478/pomr-2021-0054.
5. H. E. M. A. Shalan, M. A. Moustafa Hassan, A. B. G. Bahgat, "Comparative Study on Modelling of Gas Turbines in Combined Cycle Power Plants", *Proceedings of the 14th International Middle East Power Systems Conference (MEPCON'10)*, Cairo University, Egypt, December 19-21, Paper ID 317, 2010.
6. E. Tsoutsanis, N. Meskin, M. Benammar, K. Khorasani, "Dynamic Performance Simulation of an Aeroderivative Gas Turbine Using the Matlab Simulink Environment", *Proceedings of the ASME International Mechanical Engineering Congress & Exposition*, November 2013, California, USA, 2013, doi.org/10.1115/IMECE2013-64102.
7. A. Lazzaretto, A. Toffolo, "Analytical and Neural Network Models for Gas Turbine Design and Off-Design Simulation", *Int. J. Appl. Thermodynam.*, vol. 4, no. 4, pp. 173–82, 2001.

8. S. Serbin, B. Diasamidze, and M. Dzida, "Investigations of the working process in a dual-fuel low-emission combustion chamber for an FPSO gas turbine engine" *Polish Marit. Res.*, vol. 27, no. 3, 2020, doi: 10.2478/pomr-2020-0050.
9. A. Witkowska, T. Niksa-Rynkiewicz, "Dynamically positioned ship steering making use of backstepping method and artificial neural networks", *Polish Marit. Res.*, vol. 4, pp. 5-12, 2018, doi.org/10.2478/pomr-2018-0126.
10. M. Seera, C. P. Lim, S. Nahavandi, C. K. Loo, "Condition monitoring of induction motors: A review and an application of an ensemble of hybrid intelligent models", *Expert Systems with Applications*, vol. 41, no. 10, pp. 4891-4903, 2014, doi.org/10.1109/INDEL.2016.7797800.
11. T. Niksa-Rynkiewicz, N. Szewczuk-Krypa, A. Witkowska, K. Cpałka, M. Zalasiński, A. Cader, "Monitoring Regenerative Heat Exchanger in Steam Power Plant by Making Use of the Recurrent Neural Network", *Journal of Artificial Intelligence and Soft Computing Research*, vol. 11, pp. 143-155, 2011, https://doi.org/10.2478/jaiscr-2021-0009.
12. H. R. Depold, F. D. Gass, "The application of expert systems and neural networks to gas turbine prognostics and diagnostics", *J. of Engineering for Gas Turbines and Power*, vol. 121, no. 4, pp. 607-612, 1999, doi.org/10.1115/1.2818515.
13. H. Asgari, X. Chen, R. Sainudiin, M. Morini, M. Pinelli, P. R. Spina, M. Venturini, "Modeling and Simulation of the Start-Up Operation of a Heavy-Duty Gas Turbine by Using NARX Models" *Proceedings of the ASME Turbo Expo 2014: Turbine Technical Conference and Exposition. Volume 3A: Coal, Biomass and Alternative Fuels; Cycle Innovations; Electric Power; Industrial and Cogeneration. Düsseldorf, Germany. June 16–20, 2014, V03AT21A003 ASME*, doi.org/10.1115/GT2014-25056.
14. W. Molla Salilew, Z. Ambri, A. Karim, A. T. Baheta, "Review on gas turbine condition based diagnosis method" *Materials Today: Proceedings*, 2021, ISSN 2214-7853, doi.org/10.1016/j.matpr.2020.12.1049.
15. J. S. R. Jang, "ANFIS: adaptive-network-based fuzzy inference system" *IEEE Transactions on Systems, Man and Cybernetics*, vol. 23, no. 3, pp. 665-685, 1993, doi: 10.1109/21.256541.
16. B. Shahriari, A. N. Shahrabaki, A. Shahriari, "Gas turbine fault detection and isolation using adaptive neurofuzzy inference system (ANFIS)" *Advanced Materials Research*, vol. 1016, pp. 721-725, 2014, doi: 10.4028/www.scientific.net/AMR.1016.721.
17. Yu Zhang, S. Cruz-Manzo, A. Latimer, "Start-up vibration analysis for novelty detection on industrial gas turbines" 2016, doi: 10.1109/INDEL.2016.7797800.
18. S. Jafari; S. A. Miran Fashandi, T. Nikolaidis, "Modeling and Control of the Starter Motor and Start-Up Phase for Gas Turbines" *Electronics*, vol. 8, p. 363, 2019, doi.org/10.3390/electronics8030363.
19. N. Chiras, C. Evans, D. Rees, "Nonlinear Gas Turbine Modelling Using Feedforward Neural Networks" 2002, doi: 10.1115/GT2002-30035.
20. T. Brotherton, G. Jahns, J. Jacobs and D. Wroblewski, "Prognosis of faults in gas turbine engines" 2000 IEEE Aerospace Conference. Proceedings (Cat. No.00TH8484), vol. 6, pp. 163-171, 2000, doi: 10.1109/AERO.2000.877892.
21. M. Adamowicz, G. Żywica, "Advanced Gas Turbines Health Monitoring Systems" *Diagnostyka*, vol. 19, no. 2, pp. 77–87, 2018, doi: 10.29354/diag/89730.
22. J. Lee, F. Wu, W. Zhao, M. Ghaffari, L. Liao, D. Siegel, "Prognostics and health management design for rotary machinery systems – Reviews, Methodology and Applications" *Mechanical Systems and Signal Processing*, vol. 42, pp. 314–334, 2014, doi.org/10.1016/j.ymssp.2013.06.004.
23. K. Kanelopoulos, A. Stamatis, K. Mathioudakis, "Incorporating Neural Networks into Gas Turbine Performance Diagnostics", *ASME paper, 97-GT-35*, 1997, doi.org/10.1115/97-GT-035.
24. M. D. Zeiler, Adadelta: "An Adaptive Learning Rate Method", 2012.



## CONTACT WITH THE AUTHORS

**Tacjana Niksa-Rynkiewicz\***  
*e-mail: [tacjana.niksa@pg.edu.pl](mailto:tacjana.niksa@pg.edu.pl)*

Gdańsk University of Technology  
Faculty of Mechanical Engineering  
and Ship Technology  
Institute of Ocean Engineering  
and Ship Technology  
Gdańsk  
**POLAND**

**Anna Witkowska**

Gdańsk University of Technology,  
Faculty of Electrical  
and Control Engineering  
Gdańsk  
**POLAND**

**Jerzy Głuch**

Gdańsk University of Technology  
Faculty of Mechanical Engineering  
and Ship Technology  
Institute of Energy  
Gdańsk  
**POLAND**

**Marcin Adamowicz**

**POLAND**