

Multi-stage magnetic-fluid seals for operating in water – life test procedure, test stand and research results

Part I

Life test procedure, test stand and instrumentation

Leszek Matuszewski, Ph.D.
Gdansk University of Technology, Poland

ABSTRACT



The edge criteria for magnetic-fluid seals durability research are critical for the seal's technological usefulness. The magnetic fluid seal technology in water is much more difficult technological problem in comparison to gas or vacuum environment. There is always problem with immediate contact between magnetic fluid and the environmental uninspected liquids. In the paper are presented ways of experiments definitions carried out with multi-stage rotating magnetic fluid seal operating in permanent contact with utility water. The special test procedures have been elaborated and practically used, with the aim to define main characteristics of magnetic fluid seals. These characteristics were: critical pressure, critical motion velocity and working life of the seal. Some grades of commercial, silicon based magnetic fluids of hydrophobic properties were tested in sealing system. The test stand and its features as well as results of tests are presented in the form of tables, cross section draws and diagrams. In conclusion one can see that multi-stage magnetic-fluid seals could be efficiently used in water for rotating shaft seals in a limited range of motion velocity and work lasting.

Keywords: shaft sealing; utility water; seal durability; critical pressure; critical motion velocity; magnetic fluid

INTRODUCTION

The investigations described in this paper were performed at the test stand designed and built in accordance with the below presented assumptions, especially intended for testing drives used in ocean engineering. The research was financially supported in the frame of research projects of Ministry of Science and Higher Education and NCBR. Many elements of the research methods, measurement data recording and maintenance techniques are entirely original. Therefore it is necessary to describe the applied research process and procedures. Results of testing the single-stage magnetic-fluid (MF) seals have been already published earlier and those dealing with multi-stage ones are given in the second part of this elaboration. The problem in question is below presented on the background of the state of engineering with reference to the most important details given already in the paper [18].

This paper relates results of a continuation of the tests of MF seals in liquid environment, carried out in 2011, this turn with the use of multi-stage sleeves. Worth reminding that the magnetic fluid seals operating in liquid environment are exposed to loss of tightness due to action of factors which occur during direct inter-phase contact of two environments being in the same physical state – magnetic fluid and sealed liquid.

It is hard to compare the problem with the situation where gas environments have to be separated. The basic condition to be fulfilled in designing the seal is to select a magnetic fluid (or environment liquid) of such physical chemical properties that the liquids being in contact to each other do not mix together and on their separation surface a high inter-phase surface tension occurs. In static conditions (i.e. when seal elements do not displace against each other), if only the system is properly designed, satisfaction of the above mentioned conditions usually ensures correct work of the seal. Lack of susceptibility to mixing and high inter-phase surface tension are as a rule insufficient if a MF seal has to be applied in conditions of seal motion or sealed liquid flow in vicinity of the seal. Relative motion of the two liquids generates a surface instability on the boundary of the phases [2, 3], whose intensity greatly increases above certain limiting difference in velocity, that results in washing away the magnetic fluid and loss of tightness of the system along with time. Life time of such seal drops below its profitability.

In the published elaborations [4, 5, 6] are described attempts at determining possible conditions of operation of MF seals in water, depending on pressure and motion speed. In the work [7] are presented investigations on application of MF seal to sealing lubrication oil, and in [8] is given an attempt at design

optimizing the seal intended for the operating also in oil. In the paper [9] its authors present a concept of the „magnetic surface tension” and its impact on MF seal operation in water.

Some years earlier in AGH Laboratory, the tests of MF seals operating in utility water environment were carried out [12, 13, 14] in order to assess their applicability in shipbuilding. Results of the tests conducted in the years 2009–2010 on the test stand adjusted to operation of the seals in liquids [15] showed that it is possible to apply some commercial magnetic fluids to MF seals operating in direct contact with water in working conditions which occur in many devices met not only in ocean engineering. In the tests of a utility character single-stage MF seals – models of real seals with magnetic fluid - were used; their working conditions were limited only to the assigned technical task, i.e. assessment if performing the tests is purposeful.

In this work are described experimental tests of a magnetic fluid seal of three sealing stages, carried out in its direct contact with water and in ship propulsion conditions as well.

Alike as at the tests of the pack with single-stage sleeve, the tests were performed in variable magnetic field conditions (different number of permanent magnets in magnetic system of the seal), for different set-up values of working pressure and the same magnetic fluid dose delivered to the sealing stages.

In the presented tests a sleeve of three unsymmetrically arranged sealing stages was used. The application of the unsymmetrical (one-sided) arrangement of sealing stages had the practical aim similar to that as in the tests of single-stage seal [18]. In such arrangement the closing of magnetic field is realized by the cylindrical part of the sleeve fitted with a special longitudinal groove, that makes it possible to drain away any leakage and diagnose continuously working state of the seal.

For realisation of the tests was built a test stand, called shortly MFSL-135, composed of a special, purpose-oriented testing head, driving system containing an electric motor and its operation controller, as well as measuring system composed of gauges and transducers for measuring pressure, torque of driving motor and detecting leakage from the tested seal. The test stand is fitted with multi-channel measuring apparatus for measurement, data acquisition, processing and recording.

In the research concept it was assumed to perform short and long - term measurement tests which would make it possible to determine limiting operation features of the MF seals in water, and consequently to predict service life of seals of the type operating in working systems of ocean engineering units. To check influence of both external and structural factors on the seal's operation, it was assumed to perform the tests under different working pressure values of water as well as with switched-on magnetic systems adjusted to generating magnetic field of different intensity within the sealing system.

The design solution of the testing head and measuring system enables also to perform tests of other kinds, e.g. tests of hybrid seals composed of a magnetic-fluid seal and pneumatic shield which prevents the first from direct contact with water. The tests of the MF seal with pneumatic shield performed in the frame of this project were presented in the form of a lecture given during a technical scientific conference [19].

In this paper are presented: the test stand, research concept and assumptions, as well as the criteria necessary for assessing correctness of measurement tests. Also, a programme of the tests, their scope and instrumentation as well as magnetic fluids used for the tests, are described. Moreover, testing procedures, technique of preparation and performance of the tests are highlighted in this part, and the research results are presented in the second part of the article.

RESEARCH CONCEPT

Research hypotheses

Effectiveness of MF seal in the case of direct contact between ferromagnetic fluid and water on the inter-phase surface depends on many external factors as well as physical chemical features of the ferromagnetic fluid used in the seal.

On the basis of the observations and research experiments as well as determination of magnetic fluid features, made during the tests of single-stage MF seals [18], was elaborated the research concept adjusted for conducting the tests of multi-stage MF seals operating in water, and assessing their results.

In the tests in question were used magnetic fluids of physical chemical features determined by their producer, and standardized testing procedures. Elaboration of appropriate procedures and obeying them was a necessary condition for correct assessing influence of external factors on effectiveness of seal operation.

The following basic research hypotheses concerning influence of external factors were advanced:

- **Hypothesis I**
 - Life of MF seal depends on relative speed of its motion in utility water environment.
- **Hypothesis II**
 - In the critical pressure range specific for a given MF seal its life depends on relative value of set-up working pressure in relation to critical pressure.

Relative pressure

Loss of tightness of multi-stage MF seal is a much more complex process than that in the case of single-stage seal. It consists in penetration, resulting from exceedance of critical pressure in successive sealing stages; total penetration pressure of multi-stage seal is a sum of pressure increments causing penetration of successive stages. Worth mentioning that in most cases critical pressure of multi-stage seal is lower than simple multiplicity of critical pressure of single-stage seal of the same geometry and magnetic field parameters [20, 21]. However for purposes of the realized tests was made a simplified assumption that penetration pressure values of successive stages are equal to each other.

As absolute value of working medium pressure greatly affects seal life [18] the original concept of relative pressure was used in the research on magnetic fluids of different critical pressure values. With a view of complexity of the problem the concept in question should be highlighted.

In this research, for each of the tested MF fluid, critical pressure tests were performed with the use of a three-stage seal. The critical pressure of one stage of the seal can be defined as follows:

$$p_{krl} = \frac{1}{3} p_{krlII} \quad (1)$$

On the basis of the assumed critical pressure of one stage of the seal the relative pressure was defined as the ratio of the set-up working pressure of the seal and the critical pressure determined for one sealing stage:

$$p_w = \frac{p_r}{p_{krl}} = 3 \frac{p_r}{p_{krlII}} \quad (2)$$

where:

- p_w – relative pressure,
- p_r – working pressure (set-up for test),
- p_{krl} – critical pressure of one sealing stage,
- p_{krlII} – total critical pressure of a three-stage seal.

RESEARCH ASSUMPTIONS

The following research assumptions were made:

- **Assumption I**
In the tests magnetic fluids of hydrophobic properties, produced by specialized producers (*FerroLabs*) [17], available on the market, will be used.
- **Assumption II**
The tests will be conducted with the use of three-stage seals of 50 mm nominal diameter, already implemented in the previous tests, and 0.1 mm height of the gap filled with magnetic fluid, that should make it possible to compare results of these tests and those performed earlier.
- **Assumption III**
Magnetic field which keeps magnetic fluid in the gap, will be generated by the set of permanent magnets in the form of discs circumferentially and uniformly located between pole shoes of magnetic system. The tests are assumed to be performed for different magnetic fields, that will be realized by changing number of magnets in the magnetic system of the seal.
- **Assumption IV**
The highest motion speed at which, after reaching 1 mln cycles (number of rotations), the tested seal does not yet lose its tightness, will be called the long-term operation speed of a seal in given working conditions.

MEASUREMENTS AND CRITERIA FOR THE DETERMINING OF LIMITING PARAMETERS

Measurements of limiting parameters

The measurements were conducted on the basis of standard measurement tests of three types.

- **The test of total statical critical pressure of the seal.**
The test is realized in statical conditions (motionless shaft). During the test the pressure is continuously increased till occurrence of seal leakage symptoms. The test is aimed at determination of a pressure value which will serve as the basis for the determining of relative pressure values to be applied in the tests.
- **The test of critical speed of the seal**
The measurement of seal critical speed results in continuous increasing rotational speed of the shaft with a constant acceleration, the same for all the tests, till occurrence of seal leakage symptoms. For each relative pressure value used in the research the separate critical speed test is performed. The test is aimed at determination of the highest speed beginning from which the series of measurements of long-term operation of the seal is commenced.
- **The test of long-term operation of the seal**
The test of long-term operation of the seal is composed of the series of measurements conducted for a set-up relative pressure and constant rotational speed of the shaft. Successive measurements are taken at lower and lower rotational speed till reaching the speed at which no leakage of the seal is observed during the period of 1 mln cycles of its operation. On the basis of the obtained results the diagram of seal life versus its motion speed at a given relative pressure, is elaborated.

Criteria and way for the determining of values of limiting parameters

For all the tests lack of leakage was the criterion of correct operation of the seal.

- **The total statical critical pressure of the seal, p_{krIII}**
The total statical critical pressure is such pressure value at which the first leaking drop is observed in the drainage tank or a leakage is recorded by the leakage detector.
- **The statical critical pressure of one seal stage, p_{krI}**
The statical critical pressure of one seal stage was assumed to be equal to one third of the total statical critical pressure of the seal: $p_{krI} = 1/3 p_{krIII}$
- **Critical speed of the seal**
The critical speed of the seal is the lowest value of seal motion speed at which the first drop of leakage is observed in the drainage tank during measurements with continuously increasing speed.
- **Long-term operation speed of the seal**
The long-term operation speed of the seal is equal to the highest rotational speed of the seal, at which no leakage of the seal is observed during the period of 1 mln cycles of its operation.

SCOPE AND PROGRAMME OF THE TESTS

Scope of the work to be performed during the tests in question comprised both short-term and long-term tests. In the tests conventionally called short-term the statical critical pressure and critical speed of the seal was determined, whereas the tests performed in an extended period, conventionally called long-term ones, were aimed at determination of seal life values.

The measure of pressure, used in the tests, was the relative pressure p_r/p_{krI} determined as the ratio of the set-up working pressure and the critical pressure of one seal stage, highlighted and calculated according to the principle given in Ch. 2.2.

In spite of that occurrence of leakage was the main criterion for assessing correct operation of the seal, the following was also measured during the tests: friction moment, seal temperature, shaft rotational speed and pressure. The quantities were used to control run of the tests.

The main tests were performed with the use of magnetic fluids of three kinds applied to the seal of three stages with 0.1 mm magnetic fluid gap height.

In the frame of supplementary research the tests were performed with one kind of magnetic fluid and different numbers of permanent magnets in the seal magnetic system.

Programme of the main tests

The following programme of the tests was prepared:

- Tests of the total statical penetration pressure of the seal.
- Tests of the critical speed of seal operation at the values of the relative pressure p_r/p_{krI} equal to: 0.8; 1.6 and 2.4 multiplicity of the one-seal-stage critical pressure.
- Tests of the seal life at the values of the relative pressure p_r/p_{krI} equal to: 0.8; 1.6 and 2.4 multiplicity of the one-seal-stage critical pressure and different motion speeds beginning from that equal to or near the critical seal speed up to that at which the seal life reaches at least 1 mln cycles.

In the main tests the three selected kinds of magnetic fluid were tested. The performed measurements were later repeated. If the result of the first test differed from the repeated one by more than 10 %, the next, explanatory, test was performed. During running the tests some of them were repeated if necessary.

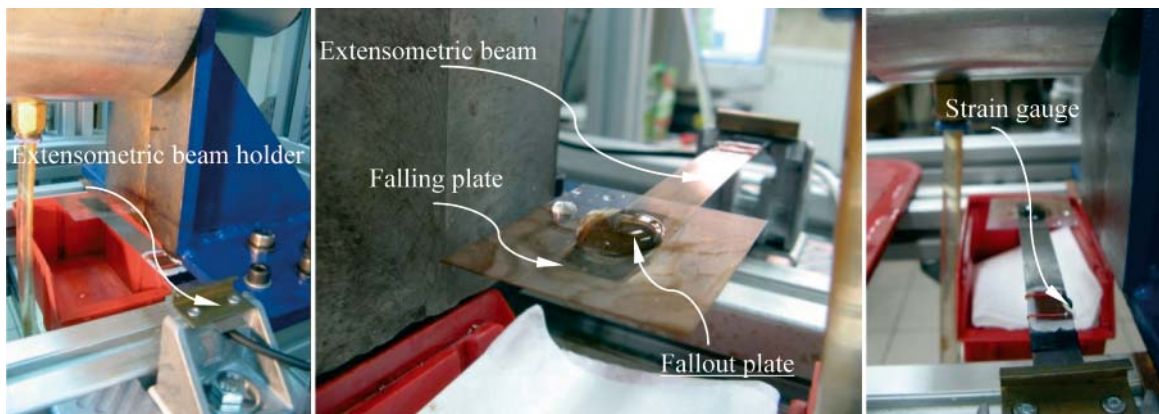

Fig. 1. Extensometric leakage detector at the test stand, in its working state

Programme of the supplementary tests

The supplementary tests were performed with the use of one magnetic fluid (FLA 003.45), selected for these tests on the basis of the results obtained from the main tests. The tests in question were conducted with the number of permanent magnets decreased to 10 pieces and the number of them increased to 18 pieces as compared with the permanent magnets of 14 in number used in the main tests.

In the future is planned realization of the programme of supplementary tests in the same range as that above mentioned for the main tests, as well as determination of minimum intensity of the magnetic field related to N35 standard magnets (of the same volume).

MFSL-135 TEST STAND

The test stand symbolically marked MFSL-135, was designed and built for purposes of this research project. It serves for the testing of magnetic fluid seals operating in contact with water or another non-aggressive liquid, and may be also used for the testing in the environment of air or another non-aggressive gas. Dimensions of the stand's head allow to place in it magnetic fluid seals of up to about 80 mm in diameter. For filling the gaps of sealing stages it is necessary to use only the small amount of magnetic fluid, i.e. of abt. 50-200 μl .

The MFSL 135 test stand makes it possible to determine statical seal penetration pressure, limiting seal operation speed and seal life at a given rotational speed in the range up to 100 s^{-1} and pressure up to 0.5 MPa.

Design of MFSL-135 test stand

The multi-functional test stand MFSL-135 intended for the testing of magnetic fluid seals was presented in detail in the previous papers published in this journal, and in the papers [1] and [18]. The full list of its particular units and elements was also given there.

Leakage detector

During the previous tests, necessity of automatic leakage detection was stated in connection with troubles in unambiguous identification of instant of a leakage. Leakage identification during the tests with the use of the MFSL 135 stand was initially based on observation of outflow of water drops from the testing head outflow hole since drop of water pressure or disturbances of torque values during operation of the three-stage seal did not provide an appropriate diagnostic signal. As during the long-

term testing it was not always possible to observe a leakage, an automatic leakage detecting system was designed.

In the photo, Fig. 1, presenting the test stand the leakage detector located in the outflow zone of leaking drops, was shown.

The device is composed of a high-sensitive extensometric beam fastened in a holder, with a glued strain gauge and a falling plate located just under outflow of drops from the casing of MFSL-135G head. The strain gauge was connected to an amplifier and one of the measuring card channels, that ensures recording even single drops flowing out of the testing head casing.

Measuring system of MFSL 135 test stand

In the paper [18] the schematic measurement diagram of the MFSL 135 test stand was shown. The list of particular units and elements of the stand was given in the description of the figure.

Design of particular elements of MFSL 135 test stand

The structural solid model of the test stand was presented in the previous papers published in this journal, e.g. [18].

MFSL-135G testing head

In Fig. 2 is shown the cross-section of the MFSL-135G testing head, where its most important parts are shortly named.

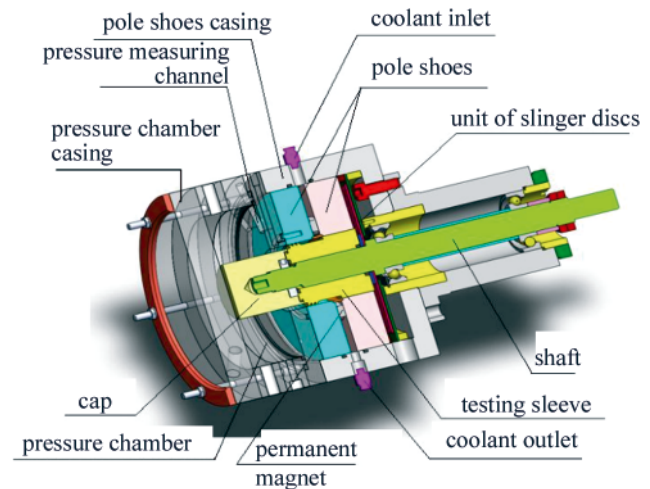

Fig. 2. Model of MFSL-135G testing head, elaborated by using Solid Works software

The shaft made of a non-magnetic steel is rotationally seated in the casing by means of the unit of rolling bearings: radial and angular one. At the end of the shaft is placed a replaceable testing sleeve made of a steel of high magnetic permeability. Axial position of the testing sleeve is fixed by means of the cap fitted with internal threaded hole. The cap, after being screwed on the threaded end of the shaft, presses down the testing sleeve to the unit of slinger discs, and then to the rotary shaft shoulder. The testing sleeve is placed in the hole of the unit of pole shoes made of a material of high magnetic permeability, seated in the casing of a non-magnetic material. Between the pole shoes the unit of permanent magnets is located. The axial position of the pole shoes is fixed by means of the pressure measuring disc and pressure chamber casing which is screwed down to the pole shoes casing by using the unit of bolts and nuts. In the pole shoes casing the inlet and outlet holes are made for the medium which cools the pole shoes during testing.

In Fig.3 the three-stage testing sleeve used in the tests in question, is presented. In the part a) of the figure the cross-section of the sleeve solid model is shown, and in the part b) – the view of the testing sleeve after series of the performed tests.

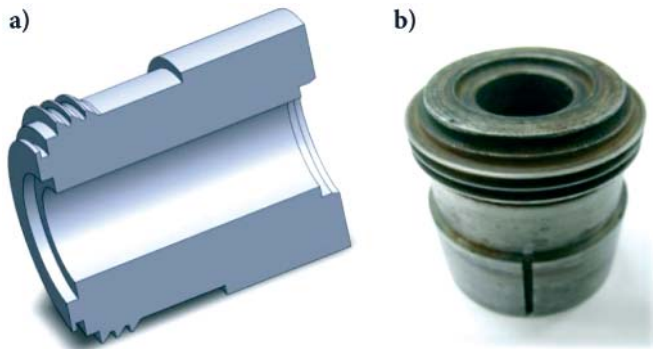

Fig. 3. Three-stage sleeve: a) model; b) real sleeve

In Fig. 4 is presented design structure and operation principle of the tested magnetic-fluid sealing system of three sealing stages. It shows the course of magnetic field lines, location of the sealing stages and cylindrical part with leakage draining groove, as well as location of water zone in the testing chamber. Direction of water flow through the leakage

draining groove after loss of tightness by the sleeve, is indicated by the arrow. In the system the rotary slinger disc is placed between the sleeve with stages and the shaft shoulder, and the permanent disc - between the unit of pole shoes and the rear wall of the pole shoes casing.

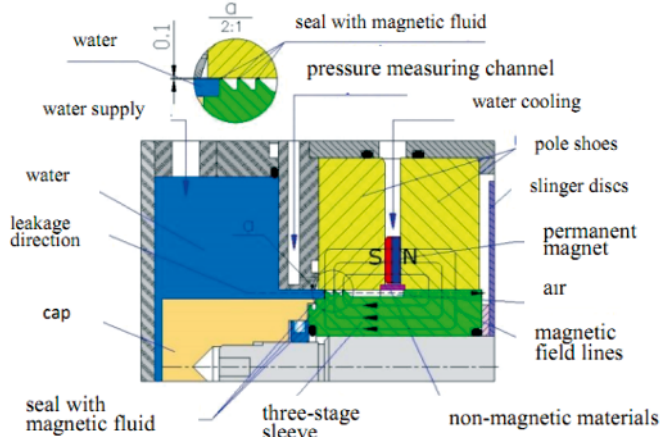

Fig. 4. Design structure of the tested magnetic fluid sealing system with three sealing stages

The rotary disc is aimed at discharging leaking drops onto internal surface of the casing from which they are gravitationally discharged through the leakage outflow hole located in the lower part of the casing, down to the leakage detector plate to trigger recording the leakage instant by LabView software.

In Fig. 5 are shown details of way of bearing the shaft of MFSL-135G testing head as well as of tension control of the angular bearing. From the side of the pole shoes the shaft is seated in the radial bearing whose axial position is fixed by the internal retaining ring. On the shaft, from the side of the drive, is mounted the angular bearing whose tension is controlled by means of the threaded bearing sleeve.

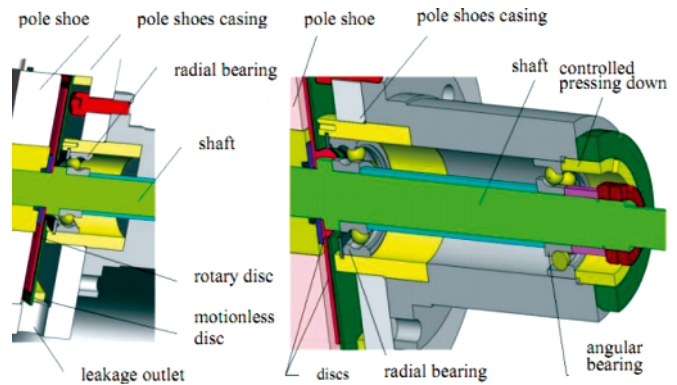

Fig. 5. Slinger discs: motionless and rotary one, mounted in MFSL-135G head

GEOMETRICAL AND STRUCTURAL CHARACTERISTICS OF THE SEAL

In Fig. 6 are shown basic dimensions of the sleeve with sealing stages, arrangement and dimensions of the stages, as well as dimensions of the magnetic system of the seal.

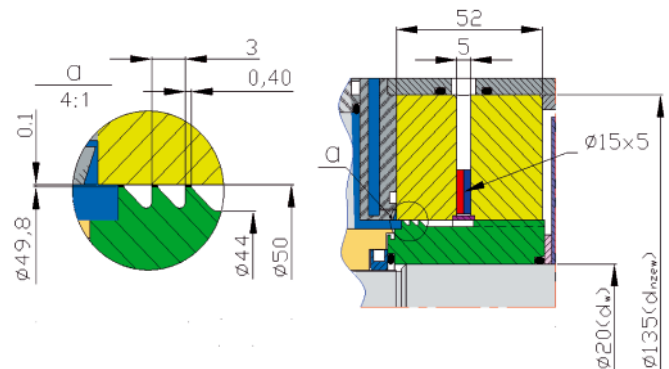

Fig. 6. Basic dimensions of the sleeve with sealing stages and dimensions of the magnetic system of the magnetic fluid seal used in the tests

In Tab. 1 are collected the geometrical and structural parameters of the magnetic fluid seal. The parameters are divided into changeable and constant ones during testing cycle.

MATERIALS AND DEVICES USED DURING THE TESTS

Magnetic fluids

The tests were conducted with the use of three magnetic fluids characterized in Tab. 2. In the table physical features of the tested fluids are compared and their typical technical applications presented.

Tab. 1. Geometrical and structural parameters of the magnetic fluid seal used in MFSL-135G testing head

PARAMETER	Value
Quantities constant during testing	
Shaft diameter, d_w	20 mm
External diameter of pole shoes, $d_{n\ zew}$	135 mm
Breadth of pole shoes unit, d_{nl}	52 mm
Diameter of three-stage sleeve, d_{III}	49,8 mm
Number of stages of testing sleeve, z	3
Nominal gap height, δ	0.1mm
Diameter of permanent magnets, d_m	15 mm
Height of permanent magnets, h	5 mm
Amount of magnetic fluid delivered to each of the stages	100 μ l
Number of permanent magnets fastened in the head casing	10; 14; 18
Working medium	water
Quantities changeable depending on a type of testing	
Rotational speed	1 – 100 rps
Range of set-up values of working pressure	0 – 0.22 MPa
Set-up values of relative pressure, $p_w = p_r/p_{krl}$	$p_r/p_{krl} = 0.8; 1.6; 2.4.$
Cooling intensity	Flow controlled by indications of head temperature transducer
Head starting-up duration time up to instant of reaching the working speed	250 s – for measurements of limiting speed 20 s – for measurements of operation time to leakage

Tab. 2. The most important parameters of the tested ferromagnetic fluids [17]

PARAMETER	Kind of fluid:		
	FLS 040.040	FLA 002.25	FLA 003.45
Kind of suspension vehicle:	Silicone liquid	Siloxane	Siloxane
Saturation magnetization, A/m	40 ÷ 50	25	45
Working temperature, °C	-70 do 150	-70 do 150	-70 do 150
Critical temperature, °C	200	250	200
Freezing temperature, °C	-100	Lack of data	Lack of data
Plastic viscosity in 27°C temperature	0.3-0.8 Pa·s	700-750 mPa·s	400-500 mPa·s
Colour of fluid:	black-brown	black-brown	black-brown
Evaporation index, $g \cdot Sm^{-2}c^{-1}$	Lack of data	$1.0 \cdot 10^{-7}$	$1.0 \cdot 10^{-7}$
Heat conductivity coefficient in 38°C temp., mWt/m·K	Lack of data	150	150
Applications:	Sealing of fermentation tanks, sealing at high motion speeds, for food industry	For speakers of medium and full range as well as sirens	For speakers of low tone and sirens

Permanent magnets

In the tests the permanent magnets in the form of discs of $\phi 15 \times 5$ mm dimensions were used. They were purchased from the firm ENES [22]. Their assembling consisted in uniform circumferential location of them in an appropriate number 14; 10; 18 pieces, respectively.

The basic features of the permanent magnets used in the tests are given below:

- magnetic material Neodymium N38
- residual magnetic induction $B_r = 1.23$ T
- coercive force $H_c = 912$ kA/m
- maximum energy density $(BH)_{max} = 294$ kJ/m³
- maximum working temperature 150 °C

Pole shoes and sealing stage sleeves

The pole shoes and sealing stage sleeves were manufactured of a low-carbon steel with the relative magnetic permeability $\mu_r > 2000$.

Magnetic fluid feeder and tool for the assembling/disassembling of sleeves with sealing stages

For dosing the magnetic fluid the laboratory feeder LabMATE LM 100 of HTL firm, was used [23]. The feeder makes it possible to dose the fluid in the amount from 10 to 100 μ l with the filling accuracy error of ± 0.8 % and repeatability error of ≤ 0.3 %.

For the filling process the spouts of 200 µl capacity made by UNITIPS® firm were applied.

To apply magnetic fluid to multi-stage seal it was necessary to use a special device as the sleeve with sealing stages was subjected, during its mounting, to action of a very strong magnetic field. The device was aimed at stabilization of the sleeve with sealing stages in a position which could make it possible to deliver magnetic fluid to successive sealing stages.

PROCEDURES FOR CONDUCTING THE TESTS AT THE MFSL 135 TEST STAND

To obtain repeatability of results of measurements aimed at determining critical pressure, critical motion speed and life of magnetic fluid seal it was necessary to elaborate and apply uniform testing procedures. Such procedures applicable to all the tests in question are described below.

Procedure of test stand preparation to conducting the tests

The procedure which makes it possible to conduct the tests consists in mounting the sleeve in an appropriate sequence, ends with application of a magnetic fluid and filling the testing chamber with utility water.

Procedure of determination of critical pressure of the seal

1. After 60 min passing from magnetic fluid application, to activate measurement mode at the control panel and Labview software, open the valve cutting-off compressed air inflow, set-up the flow throttling valve to the pressure increase rate within the range of (0.001÷0.005) MPa/s.
2. To increase the pressure till a leakage from the seal appears and simultaneously observe possible drop of pressure.
3. After ending the test, to deactivate the measurement mode of LabView software.
4. To read, from the Labview records, the maximum pressure value observed during the test (i.e. the pressure at which penetration of the seal occurred).
5. To introduce the measurement data into the testing card.
6. To empty and open the testing chamber.
7. To dismount and clean, by using extraction naphtha, all elements of the seal and testing head.

Procedure of determination of critical motion speed of the seal

1. To activate measurement mode at the control panel and LabView software.
2. To set up frequency converter to the maximum frequency value of 100 s⁻¹ and speed rise time of 250 s.
3. After 45 min passing from magnetic fluid application, to set up water pressure in the chamber in compliance with the relative pressure value $p_r/p_{krt} = 0.8; 1.6; 2.4$, respectively – in line with the testing programme.
4. After 60 min passing from magnetic fluid application, to start up the water cooling circuit of the sealing system (for seal temperature stabilization), and next – start up the drive motor.
5. To monitor increasing rotational speed of the motor and occurring leakage due to lack of tightness of the magnetic fluid seal.

6. After occurrence of lack of tightness to stop the motor and LabView software work.
7. From Labview software records and monitored leakage occurrence instant, to determine the maximum value of rotational motion speed of the seal. The speed at which the leakage occurred is that critical for the seal.
8. To introduce measurement data into the testing card.
9. To empty and open the testing chamber.
10. To dismount and clean, by using extraction naphtha, all elements of the seal and testing head.

Procedure of determination of seal service life

1. To activate measurement mode at the control panel and LabView software.
2. To set up frequency converter to a given rotational speed in line with the testing programme, and speed rise time of 20 s.
3. After 45 min passing from magnetic fluid application, to set up water pressure in the chamber in compliance with the relative pressure value $p_r/p_{krt} = 0.8; 1.6; 2.4$, respectively – in line with the testing programme.
4. After 60 min passing from magnetic fluid application, to start up the water cooling circuit of the sealing system (for seal temperature stabilization), and next – start up the drive motor.
5. To monitor increasing rotational speed of the motor and occurring leakage due to lack of tightness of the magnetic fluid seal.
6. After occurrence of lack of tightness to stop the motor and LabView software work.
7. From Labview software records and monitored leakage occurrence instant, to determine the leakage occurrence time passing from the start-up of the test. The time passing from the start-up of the test to the first leakage instant is the seal service life in the conditions of the test in question.
8. To introduce measurement data into the testing card.
9. To empty and open the testing chamber.
10. To dismount and clean, by using extraction naphtha, all elements of the seal and testing head.

Measurement of pressure in the MFSL-135G testing head

In the MFSL-135G testing head five pressure measuring channels are installed. Channel 1 is intended for the measuring of compressed air pressure. Channels 2 through 5 serve to measure water pressure in the testing chamber. To this end in the measurement disc are made two radial holes of different depth, connected to the testing chamber, that makes it possible to measure pressure values at different distances from shaft rotation axis. The measurements made by using Channel 2 are especially important for the performed tests as the outlet of its measurement hole is located directly in the neighbourhood of sealing stages filled with magnetic fluid. According to the programme realized in the frame of this project the pressure measurements from Channel 1 and 2 were used. Channel 1 serves to control pressure values set up in the phase of preparation of the test stand for carrying out the tests. Channel 2 makes it possible to measure water pressure just at the magnetic fluid seal. In Fig. 7 is shown an example run of the pressure in the testing head during the statical penetration test recorded by the LabView software. The record comes from Channels 2 through 5, in accordance with the pressure measurement points.

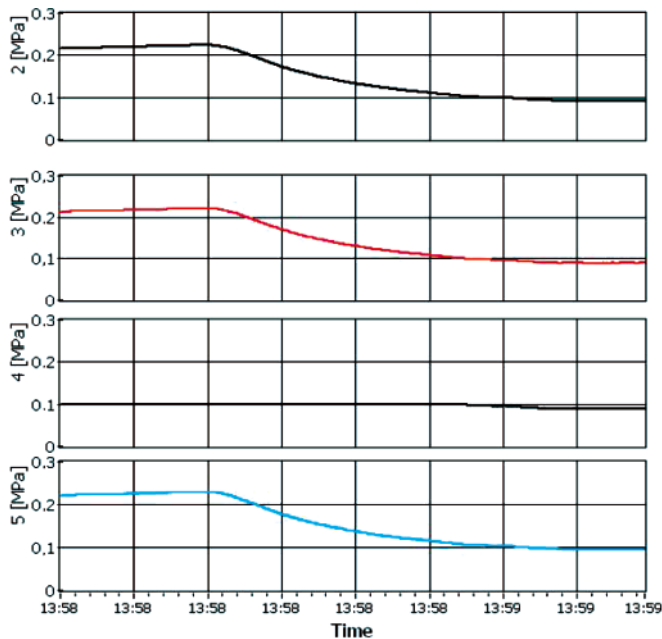

Fig. 7. An example run of the pressure in the testing head during the static critical pressure test. The image taken from the graphical interface of LabView software, for four channels (Channels 2 through 5); the pressure measurement points – as above described

SUMMARY

In compliance with the method of conducting the tests it was assumed to determine, for each of the tested version of the seal, the following:

- statical penetration pressure,
- limiting working speed.

Each of the measurements provides significant information which makes it possible to reach the assigned research aim, i.e.:

- elaboration of a seal life curve and determination of the highest motion speed for which the seal is still capable of reaching, without any failure (lack of leakage), the basic number of cycles (rotations) equal to 1 mln, as assumed in these tests.

A very important factor for the performed tests is the water pressure set-up in the measuring head. The factor was taken into account in the form of the relative pressure defined as the ratio of the set-up pressure and the critical pressure, ($p_w = p_r/p_{krl}$), defined as the seal penetration pressure per one sealing stage, obtained in the statical test.

Due to the assumption of such concept of setting-up testing pressure of water it was possible to simply take into account influence of the factor on seal life for particular tested magnetic fluids, however the assumption also makes comparison of service life of different fluids difficult because of large differences in values of the set-up statical testing pressure for the tested magnetic fluids, which result from very large differences in values of their statical penetration pressure. For instance, the highest long-term operation speed equal to 45 rps was obtained during the tests with the FLA 002.25 magnetic fluid at the set-up pressure of 0.0237 MPa ($p_w = p_r/p_{krl} = 0.8$), resulting from the low penetration pressure of the fluid equal to 0.0297 MPa per one sealing stage. Since the analogous test at the value $p_w = p_r/p_{krl} = 0.8$ for the FLA 003.045 fluid requires to set-up the water pressure value of 0.058 MPa (the penetration pressure per one sealing stage for the fluid is equal to 0.072 MPa) then

the long-term speed for the seal filled with the fluid amounts only to 20 rps. The results indicate a significant influence of pressure on service life of magnetic fluid seal operating in water. Limiting working speed of the seal brings significant research information as it makes it possible to assess the speed value from which elaboration of seal life curve should be commenced, and consequently, determination of seal life for the basic number of cycles equal to 1 mln. However from the utility point of view the parameter is rather not important.

The tests conducted with different numbers of magnets in the sealing system has to show influence of size of magnetic field on limiting speed of magnetic fluids.

The preliminary results of seal life tests for majority of the tested magnetic fluids and seals provide similar picture on the diagrams. At higher rotational speeds short working time to leakage (low number of cycles) is observed. At lower motion speeds the time to leakage appears much longer and clearly tends to a speed value at which seal operation can be considered long-term. The full results of series of the tests will be described in the other part of the article.

BIBLIOGRAPHY

1. Szydło Z., Zachara B., Ochoński W.: *Ferromagnetic fluids and their application in machinery engineering* (in Polish).1st Conference on Automation of Machines, Devices and Processes. Krynica (Poland), 1999
2. Rosensweig R. E.: *Ferrohydrodynamics*. Dover Publications, Inc. Mineola, New York, 1997.
3. Rinaldi C., Chaves A., Elborai S., He X., Zahn M.: *Magnetic fluid rheology and flows*. Current Opinion in Colloid & Interface Science Vol.10, Issue 3-4, October, 2005.
4. Orlov D. B., et al.: *Eksperymentalnoe issledovanie resursa magnitizirovannykh uplotnenij pri germetizacii zidkich sred* (in Russian). Magnitnaya Gidrodinamika, No. 4, pp.127-130, 1989.
5. Kurfess J., Muller H. K.: *Sealing liquids with magnetic fluids*. Journal of Magnetism and Magnetic Materials, 85, 1990
6. Viherala J., et al.: *Sealing of Liquids with Magnetic Fluid Seals*. Proc. of 6th Nordic Symposium on Tribology, NORDTRIB'94, Uppsala, Sweden, 12-15 June 1994.
7. Kim Y.S., Nakatsuka K., Fujita T., Atarashi T.: *Application of hydrophilic magnetic fluid to oil seal*. Journal of Magnetism and Magnetic Materials 201, 1999, pp.361-363.
8. Liu T., Cheng Y., Yang Z.: *Design optimization of seal structure for sealing liquid by magnetic fluids*. Journal of Magnetism and Magnetic Materials, Vol. 289, March 2005.
9. Guo C., Feng S.: *Sealing mechanism of magnetic fluids*. Journal of Shanghai University (English Edition), 2006, 10(6), pp.522-525.
10. Chorney Alvan F.; Mraz Will.: *Hermetic Sealing with Magnetic Fluids*. Machine Design, May 7, 1992, 64, 9, ProQuest Science Journals p. 79.
11. Mitamura Y., Arioka S., Sakota K., Azegami M.: *Application of a magnetic fluid seal to rotary blood pumps*. J. Phys.: Condens. Matter 20, 2008.
12. Szydło Z., Matuszewski L.: *Experimental research on effectiveness of the magnetic fluid seals for rotary shafts working in water*. Polish Maritime Research No. 4, 2007 vol. 14 pp. 53–58.
13. Szydło Z., Matuszewski L.: *Ring thruster – a preliminary optimisation study of ferrofluid seal and propeller*. Polish Maritime Research, S1 (Special Issue), 2007 pp. 71–74.
14. Szydło Z., Matuszewski L.: *The application of magnetic fluids in sealing nodes designed for operation in difficult conditions and in machines used in sea environment*. Polish Maritime Research, No. 3, 2008, vol. 15, pp. 49–58.
15. *A measuring head for the testing of parameters of ferromagnetic fluid seals* (in Polish). Stanislaw Staszic Academy of Mining and Metallurgy, Cracow. Inventors: Szydło Zbigniew, Ochoński Włodzimierz, Zachara Bolesław. Patent application

- PL 377598 A1, dated: 2005-10-12; published: 2007-04-16, Bulletin of (Polish) Patent Office, 2007, No. 8, p. 22.
16. Bonvouloir J.: *Experimental Study of High Speed Sealing Capability of Single stage Ferrofluidic Seal*. ASME Transactions, Journal of Tribology, Vol.119, July, 1997.
17. Ferrolabs, Inc. Sterling, VA United States, <http://www.ferrolabs.com/> 2010
18. Szydło Z., Matuszewski L.: *Life tests of a rotary single-stage magnetic-fluid seal for shipbuilding applications*. Polish Maritime Research No. 2, 2011, vol. 18, pp. 51–59.
19. Szydło Z.: *High speed magnetic fluid seal operating in water environment*. 17th International Colloquium on Tribology, 19–21 January 2010, book of synopses 2010, ed. Wilfried J. Bartz., Ostfildern, Technische Akademie Esslingen, 2010.
20. Report on realization of the KBN research project No. 7T07B 02412: *Determination of tribological characteristics and limiting working conditions of ferromagnetic fluid seals* (in Polish). Academy of Mining and Metallurgy, Cracow, 2000.
21. Jibin Zou, Jiming Zou, and Jianhui Hu.: *Design and pressure control of high pressure differential magnetic fluid seals*. IEEE Transactions on magnetics, No. 5, Vol. 39, September 2003
22. http://www.magnesy.eu/mw_15_x_5_n38_-_magnes_neodymowy-t-1798.html - product datasheet
23. http://www.htl.com.pl/produkt_53.php - product datasheet

CONTACT WITH THE AUTHOR

Leszek Matuszewski, Ph.D.
Faculty of Ocean Engineering
and Ship Technology
Gdansk University of Technology
Narutowicza 11/12
80-233 Gdansk, POLAND
e-mail: leszekma@pg.gda.pl