

Eng. Mikołaj Bartłomiejczyk, PhD.

2 *Gdansk University of Technology*
3 *Faculty of Electrical and Control Engineering*
4 *Department of Electrical Transport*
5 *ul. G. Narutowicza 11/12*
6 *80-233 Gdansk, Poland*
7 Phone +48 58 347 28 57
8 Email: mikolaj.bartlomiejczyk@pg.gda.pl

9

10 Marcin Polom, PhD.

11 *University of Gdansk*
12 *Faculty of Oceanography and Geography*
13 *Department of Regional Development Geography*
14 *ul. J. Bazyńskiego 4*
15 *80-952 Gdansk, Poland*
16 Phone +48 58 523 65 69
17 Email: marcin.polom@ug.edu.pl

18

19 **MULTIASPECT MEASUREMENT ANALYSIS OF BREAKING ENERGY**
20 **RECOVERY**

21

22 **Abstract**

23 Nowadays the issue of electric energy saving in public transport is becoming a key
24 area of interest, which is connected both with a growth of environmental awareness in the
25 society and an increase in the prices of fuel and electricity. That is why the reduction of

26 energy consumption by increasing electrified urban transport, such as trams, trolleybuses,
27 light rail and underground is becoming an increasingly important issue. Energy recovery
28 during braking is possible in all modern electric vehicles, but in many cases this possibility is
29 not fully taken advantage of, inter alia, because of an inadequate power supply structure. The
30 aim of this article is to present practical examples of implementation of eco-friendly solutions
31 in urban municipal transport. The article shows a thorough analysis of braking energy
32 dispatch in the urban traction power supply system, which was based on extensive
33 measurement research conducted in Gdynia trolleybus network. The authors applied multi
34 way measurement method using Global Positioning System. The optimal conditions for
35 implementation of several methods of energy recovery (storage energy systems,
36 reconfiguration of supply system, using auxiliaries) have been shown. Great emphasis has
37 been put on the confirmation of the results by means of research and experimental
38 measurement.

39

40 **Keywords**

41 Trolleybus, energy recuperations, public transport, supercondensators, energy consumption
42 reducing

43

44 **1. Introduction**

45 The development of zero-emissions public transport vehicles is one of the EU's
46 horizontal policies. Urban transport currently accounts for 40% [1] of total CO₂ emissions
47 generated by road traffic in Europe. The transport sector is responsible for 30% of total
48 energy consumption and 27% of greenhouse gas emissions. Among all sectors that emit CO₂,
49 the transport sector is the fastest growing one, second only to the industrial sector [2].
50 Therefore, by 2050, greenhouse gas emissions will have to be reduced by 60%. In addition,



51 the instability of liquid fuel prices has a strongly negative effect on the economy [3]. It thus
52 becomes imperative to raise the level of the usability of alternative energy sources in public
53 transport [4]. Analysis of the impact of transport on the environment and of ways of reducing
54 its harmfulness has been the subject of numerous analyses. Studies for Tianjin (China) [5] or
55 Delhi (India) [6] can be an example here. Article [5] highlights the impact of the development
56 of the city on the increase of communication needs in the years 2010 - 2040 as well as the
57 risks it could bring. If there will be no changes in next 30 years, the number of vehicles will
58 grow more than 7 times and energy consumption will rise up to 6 times. The similar increase
59 of transport energy demand (6 times in years 1997 - 2020) is estimated for Delhi and Mumbai
60 [6].

61 Electricity seems a natural alternative to liquid fuels. For this reason, European
62 authorities actively support the development of electrically-powered means of transport, as
63 manifested by co-funding initiatives promoting environmentally-friendly city transport
64 systems. For example, the *Trolley* project implemented in the years 2010-13 was aimed at
65 promoting trolleybuses and developing energy-saving technologies in these vehicles. A
66 project similar in scope was *Actuate*, whose objective is to accentuate the importance of
67 driving technique for the energy efficiency of electrically-powered transport modes and to
68 implement the concept of “eco-driving”, i.e. eco-friendly driving technique. At present, many
69 European cities support the *Dyn@mo* programme, the purpose of which is to develop modern
70 and energy-efficient technologies in urban transport. A programme focusing exclusively on
71 the technical aspect of tramway transport energy-efficiency is *Osiris*. The programme
72 participants include a team of transport companies and manufacturers of broadly-defined
73 electrical equipment [7].

74 Over the last quarter-century there have been many efforts and projects undertaken
75 related to the reduction of global energy consumption, as well as increasing the efficiency of



76 its generation and transmission [8]. Decreasing energy consumption in transport plays an
77 important role in this issue [9]. Electric vehicles can be one of the key elements in curbing
78 CO₂ emissions [10] and they can be an active part of the energy system contributing to the
79 improvement of its work and reliability [11]. An important issue related to the public transport
80 energy consumption is the impact of traffic conditions and the structure of the power supply
81 system on energy consumption and energy balance [12]. In the energy balance of the modern
82 transport system a vital role is played by recuperation of braking energy, which can be an
83 effective tool to reduce energy consumption [13]. Supercapacitor storage energy systems are
84 the most popular tool for enhancing the recuperation usage [15].

85 In classical DC supply systems of public transport (tramways, trolleybuses) recovered
86 energy can be re-used by auxiliary receivers in breaking vehicle or by other vehicles [15]. In
87 case of lack of vehicles which are accelerating at the same time, this energy is burned in
88 breaking resistors. In order to avoid the loss of recuperated energy the storage energy systems
89 can be used [14]. The importance of optimization of storage devices for regenerative
90 breaking energy is becoming a significant issue [8]. In previous years flywheels were
91 considered to be an optimal solution [16], but nowadays supercapacitors are the most popular
92 device used for recovery energy accumulation [17]. They are the subject of numerous
93 scientific research projects, both in the on-board form, placed in the vehicles and off board
94 energy storage devices situated in traction substations or off-board form in stationary places
95 of supply systems [1]. Publications are mainly focused on control algorithms [18]. There are
96 two main objects of research in literature as far as increasing energy efficiency is concerned:
97 on board energy storage devices for light electrical vehicles (LEV) like trams, trolleybuses
98 and electro buses [11] or reducing the energy consumption in heavy electrical vehicles (HEV,
99 railway, suburban railway, metro) [13]. In contrast to this, the lack of research in the field of
100 off board storage energy systems for LEV is visible. The tram and trolleybus transport is



101 highly developed in many European cities, a lot of tram and trolleybuses operators are
102 considering putting into service off board energy storage systems. In metro systems savings
103 caused by using storage energy systems can reach 44% [19], moreover the character of traffic
104 in case of LEV differs significantly from HEV and a special approach for energy consumption
105 analysis is required. The savings caused by storage energy systems can be much lower due to
106 different shape of speed profiles and the larger number of vehicles in motion [20].

107 In addition to the above, another deficiency of the present science research can be
108 mentioned: there are a lot of publications available related to the problems of design and
109 management of the recuperated storage energy systems [21]. However, they are oriented only
110 on re-using the recovered energy in storage systems. Studies on the global energy flow are
111 very rare. Nevertheless, the global system approach is a crucial element for energy analysis of
112 supply systems [22]. Very interesting analysis of the global energy supply tram system is
113 presented in the paper [23], however, its experimental verification was not carried out.
114 Several ways of implementing eco-friendly technologies with assessment of benefits were
115 presented in [24]. In [25] the importance of recovery of breaking energy was presented, which
116 was described as the cheapest way of reducing energy demand.

117 In order to make up for the gap in literature, this paper presents a comprehensive
118 overview of the options of re-usage of energy breaking in urban transport system. Firstly, the
119 aim of the authors is to present the importance of a multifaceted approach to the multi way
120 use of energy on the real case-study of Gdynia trolleybus system. In this aspect, the results of
121 the research presented in this article refer to the works [24] and [25]. Secondly, great
122 emphasis has been put on the confirmation of the results by means of research and
123 experimental measurement. Many similar analyses are based on simulation models of power
124 supply systems [26]. Nevertheless, in the view of a considerable number of factors affecting
125 urban tram of trolleybus traffic, mainly congestion with its random and unpredictable nature,



126 psychological aspects of drivers work and low repeatability of measurements [22], careful
127 analysis of the supply system using a theoretical simulation does not involve many factors and
128 is associated with inaccurate results. Thirdly, the authors present the novel method based on
129 the multi way measuring, realized both in traction substations and vehicles with GPS
130 synchronization. Due to the limited measurement possibilities, a lot of analyses of power
131 supply systems are based only on measurements made in traction substations [27] or in
132 vehicles (tramways [26] or trolleybuses [28]).The method presented in this paper is based on
133 global approach to the supply system.

134 The aim of this paper is to present the activities applied in Gdynia Trolleybus company,
135 which may be “ready to use” solutions for other transport companies. The article highlights
136 the impact of practical verification of energy reduction tools in electrified transport. The
137 novel multi way measurement method using GPS localization system was applied for this
138 purpose. Moreover, the “niche” ways of increasing efficiency, f.g. “intelligent heating” are
139 described in the article.

140

141 **2. Trolleybus transport system of Gdynia**

142 Gdynia is a harbour city at the Baltic sea with a population of 250,000. In 1943, its
143 trolleybus network was put into operation and gradually developed, later to become the
144 largest in Poland. Gdynia's trolleybus carrier, Przedsiębiorstwo Komunikacji Trolejbusowej
145 (PKT), currently operates a fleet of 85 trolleybuses on 12 services in a network, the length of
146 which reaches almost 50 km. Gdynia's trolleybus network is powered from 10 traction
147 substations in a unidirectional supply system. The traction substations differ with respect to
148 the size of areas to which electricity is supplied and the number of rectifier sets, each
149 substation powering 1 to 6 sections. Gdynia's trolleybus system consumes nearly 12 GWh of
150 electrical energy per year and is considered one of the biggest energy consumers in the city.



151 Therefore, one may reasonably expect that some steps towards reducing power consumption
152 would be appropriate [21].

153 Since 2001, PKT Gdynia has been involved in many activities related to the reduction
154 of power consumption, both in terms of implementation and research and development. The
155 former category includes putting vehicles with an energy-efficient drive into operation and the
156 installation of supercapacitor energy storage in one of the traction substations, the latter -
157 studies on the potential for a further limitation of energy consumption and methods to achieve
158 it. PKT Gdynia participates in two research and development programmes: *Trolley* and
159 *Dyn@mo*, in addition to cooperating with Gdańsk University of Technology.

160 The fleet modernization programme started in 1998 and caused a significant drop in
161 the power consumption for the PKT company: for the last 10 years the average annual
162 consumption has been reduced from 2.7 kWh/km to 2.1 kWh/km, which corresponds to a
163 22% decrease of energy consumption by trolleybus transport. The graph in Fig. 1 illustrates
164 changes in the relative number of vehicles with power electronics drive and the corresponding
165 average annual energy consumption. An increase in the number of vehicles with modern
166 propulsions system allowed to significantly reduce the consumption of energy. In order to
167 further reduce energy consumption the company started cooperation with Gdańsk University
168 of Technology which provides numerous research studies related to the broadly-defined
169 improvement in the efficiency of energy recovery.

170 The issues of reduce energy consumption in Gdynia have been the subject of many
171 scientists works and as well as analysis of the author. Some of them have theoretical
172 character. In [29] the novel method of trolleybus supply system analysis by statistical method
173 Monte Carlo was presented. The method was used in order to present the possibility of
174 reducing energy consumption by using new technologies, mainly by implementation of
175 bilateral supply system and storage energy devices. The several novel tools for urban supply



176 system such Multi Criteria Decision Analysis or statistical analysis of load probability were
177 presented in [30]. Some of practical experiences gained during exploitation of the thirist, trail
178 storage energy system were presented in [31]. This is the first study, which presents results of
179 all activites focused on the reduction of energy consumption conducted in Gdynia for a wide
180 range. Beside these it gives a general overlook of practical application of eco friendly
181 technologies in public transport.

182

183 **3. An overlook of recuperation of braking energy**

184 Every electrical machine is characterized by its capability of operating with a
185 bidirectional energy flow [32]. For traction motors it means that braking enables regenerative
186 operation which consists in converting the vehicle's kinetic energy into electrical energy,
187 which in turn generates braking torque. This allows to recuperate energy. During the start up
188 the traction motor propels the vehicle, thereby increasing its velocity. Thus, the electric
189 energy supplied to the drive system is converted into kinetic energy of the vehicle. During
190 braking, the vehicle speed is decreased, which leads to a reduction of its kinetic energy. This
191 energy can be dissipated, for example in the brake pads. Yet it is also possible to transform it
192 again into electric energy by means of an electric motor. In real conditions it is possible to
193 recover 40% of energy consumed for acceleration [29].

194 Fig. 2 presents a diagram of the energy flow in a vehicle during the braking of an
195 electric traction unit. During braking, the traction motor (TM) switches into a generator mode
196 and a transformation of the kinetic energy of the vehicle into electrical energy takes place,
197 which can then be returned to the overhead lines. However, in order to return electric energy
198 into the supply system it is necessary to generate voltage higher than the one in the overhead
199 lines. For this purpose, during braking, the traction inverter (TC) increases the voltage
200 generated by the traction motor. First, part of the generated energy is consumed in the vehicle



201 by auxiliary needs (mainly heating). The rest of the recuperated energy is directed through the
202 braking converter (BC) into the overhead lines. In the absence of reception of the braking
203 energy, voltage in the overhead lines (U_{CN}) on the vehicle's current collector exceeds the
204 maximum recuperation voltage U_{max} . This triggers the braking converter BC, which directs
205 the energy generated in the drive unit to the braking resistor. This energy is dissipated as heat.

206 An example of the balance of energy recovery is shown in Fig. 3. It presents energy
207 balance in supply areas of traction substations in Gdynia. The diagram presents energy
208 consumed from the supply system for traction purposes, total energy recovered from braking
209 and energy dissipated in braking resistors. The differentiation of recovered energy load is
210 visible. In the majority of supply areas almost all energy generated during braking is
211 consumed, but in areas of substations no. 4, 9, 10 a significant part of braking energy is
212 dissipated, and in case of substation no. 10 almost all braking energy is lost. It shows the
213 possibility of reducing energy consumption and proves the need to analyze braking energy
214 usage.

215 Effectiveness of energy recovery depends on the structure and topology of traction supply
216 system. An overhead catenary is divided into supply sections to which electrical power is
217 delivered from traction substations. In a conventional supply system, in which substations are
218 not equipped in power storage accumulators, the recovered energy may be absorbed by
219 another vehicle which is in motion and located in a power supply section capable of receiving
220 power. Yet frequently in the supply area there are no vehicles capable of absorbing power. In
221 such cases the recovered energy is wasted on the braking resistors. This results in only partial
222 use of the system's regenerative potential [29].

223 One of the methods of preventing energy losses in braking resistors is to direct the
224 recovered energy to public AC network which supplies power to traction substations equipped
225 with inverters and feed it back to the power supply network. However, this method is not



226 popular due to insufficient interest of electrical energy suppliers in purchasing the recovered
227 recuperation energy.

228 An alternative solution is to store the recovered energy in supercapacity energy storage
229 systems to reuse it to power moving vehicles in the future. The means of storing the recovered
230 energy may be located in vehicles (on-board energy storage systems) or in tractions
231 substations or in other places of supply network (off board energy storage systems). Fig. 4.
232 shows the distribution of the recovered energy in a trolleybus supply system, in which energy
233 storage is installed in a traction substation. Part of the recovered energy $E_{recuperation}$ generated
234 during regenerative braking is used to satisfy internal demand of the trolleybus (lighting,
235 auxiliary drives, heating etc.) – and is marked as $E_{auxiliary}$. The remainder of the recovered
236 energy is fed back to the contact system, in which it is partly absorbed by other vehicles in the
237 supply area ($E_{network}$), with the remainder ($E_{storage}$) stored in an energy storage facility.

238 Recuperation energy balance may be described by the following equation:

$$239 \quad E_{recuperation} = E_{auxiliary} + E_{network} + E_{storage} \quad (1)$$

240 The values of particular recuperation energy balance elements are dependent on parameters
241 such as the type of fleet in use, traffic intensity, power supply system structure, amount of
242 consumption needs of nontraction vehicles.

243 The relation between particular recuperation components may thus change. As a result, the
244 use of solutions that increase the efficiency of recovery should be subject to the space-traffic
245 conditions of the transport system. It allows to propose the following thesis: for the sake of
246 energy recovery optimization of all components of the energy recuperation balance should be
247 included, their distribution depending on many factors, predominantly the topology of the
248 power supply system. Efficient use of recovery energy is possible only basing on the synergy
249 of methods increasing the use of recuperation energy. The potential for increasing the re usage
250 of the recovered energy, on the example of Gdynia trolleybus system, is shown in Fig. 3

251 which presents measurement results of traction energy balance. Possibilities of increasing of
252 the breaking energy recovery are clearly visible, mainly in supply area of substations 4, 9, 10.

253

254 **4. Methods**

255 Gdynia's supply system was tested in this respect in the years 2011-2015.
256 Measurements were performed in traction substations and on trolleybuses. For this purpose an
257 on-board energy consumption logging system providing information on the vehicle's GPS
258 location at a given point in time was used [33]. Vehicles in service in Gdynia are fitted with
259 the system as a standard. The functionality enables precise energy consumption read-outs in
260 individual supply sections.

261 The following values were established during measurements in order to determine
262 energy recovery effectiveness indicators:

263 - in traction substations:

- 264 ▪ power supply units' voltage and current,
- 265 ▪ busbar voltages,

266 - in vehicles:

- 267 ▪ traction drive voltage,
- 268 ▪ auxiliary equipment voltage and current,
- 269 ▪ braking resistor activation time,
- 270 ▪ current collector voltage.

271 The results were based on read-outs taken from December 2011 to November 2012, with
272 the winter period defined as January and February, and the summer period defined as July and
273 August. The scheme of the measurement is shown on Fig. 5

274

275 **4.1. Recuperation for auxiliary needs**

276 The non-traction need plays a significant role in global energy consumption of transport
277 vehicles [34]. Therefore, the most efficient way to use energy recovery is its consumption
278 inside the vehicle, to non-traction needs. The main non-traction recipients of energy is heating
279 and air conditioning, whose work is highly dependent on weather conditions. Thus, the value
280 of energy used for non-traction purposes is strongly dependent on the season and weather
281 conditions. This is also reflected in the amount of recuperation energy consumed for non-
282 traction purposes. Fig. 6 shows the relative amount k of recuperation energy consumed by
283 non-traction needs in the vehicles needs (related to total energy consumption of the whole
284 trolleybus transport system) in one year scale from January to December. During the winter
285 season even more than 30% of recuperated energy can be used for non-traction purposes.

286 Recuperative energy consumption for the vehicles' non traction purposes is the most
287 effective form of energy recovery use, thus the on-board equipment should be constructed in
288 such a way that it is primarily supplied with recuperation energy. This can be achieved by e.g.
289 introducing intelligent heating: the power of heaters is raised during regenerative braking and
290 reduced while driving, which allows for an increase in the share of recuperation energy in
291 heating the vehicle. This solution was implemented in Gdynia in two vehicles. The process
292 control system is as follows: during normal driving the temperature of heating liquid in the
293 heating system is kept at the level of 60° – 70° Celsius by hysteresis controller. When braking
294 occurs, the power of heating units is increasing to its maximal value, thus necessitating
295 greater use of recuperation energy for heating needs. Fig. 7 shows the difference between the
296 recovered energy consumption for auxiliary needs in a vehicle with the standard heating
297 system and the intelligent heating system. In the intelligent heating system the usage of the
298 recovered energy for auxiliaries is even twice as high.

299

300 4.2. Recuperation for other vehicles



301 In order to recover braking energy it is necessary to ensure the receivers for the
 302 generated energy. In a classical supply system without storage energy systems, with one-side
 303 supply of catenary and without taking into account transmission losses, this means that
 304 substation load P_{TS} must be larger than power P_{rec} generated during recuperation by vehicles
 305 in the supply area of the substation. It can be written as the equation:

$$306 \quad P_{TS} \geq P_{rec} \quad (2)$$

307 If this condition is not fulfilled, only a part of recuperated power, equal to load P_{TS} , can be re-
 308 used. The remaining energy is lost in braking resistors. Therefore, due to limited load power
 309 P_{TS} of substation, it is possible to use only a part of the generated energy.

310 The influence of changeable substation load P_{TS} on the possibility of absorption of
 311 generated power has been examined [30]. It has been analyzed how much energy from the
 312 source with power P_{gen} the supply system with changeable value of load $P_{TS}(t)$ is able to
 313 absorb. Source P_{gen} is an equivalent of vehicle during regenerative braking. The calculations
 314 were based on registrations of loads $P_{TS}(t)$ of traction substations in Gdynia.

315 For this purpose, function $e(P_{gen})$, which expresses the relative amount of generated
 316 energy from source P_{gen} in time T , has been defined:

$$317 \quad e(P_{gen}) = \frac{\int_0^T P_{Ch}(P_{gen}, t) dt}{P_{gen} \cdot T} \quad (3)$$

318 $P_{Ch}(P_{gen}, t)$ expresses the limit of absorption of generated energy:

$$319 \quad P_{Ch} = \begin{cases} P_{gen} < P_{TS} \rightarrow P_{Ch} = P_{gen} \\ P_{gen} \geq P_{TS} \rightarrow P_{Ch} = P_{TS} \end{cases} \quad (4)$$

320
 321 In Fig. 8 the values of relative usage of generated energy are presented. Characteristics of two
 322 substations: TS 2 and TS 9, are shown. These two substations are significantly different in
 323 terms of traffic intensity. TS 2 supplies large supply area with high density of traffic (every 3

324 minutes), whereas TS 9 supplies the sub-urban line with a minor traffic intensity (30 minutes).
325 The difference in the traffic intensity is reflected in the possibility of using regenerative
326 braking. Assuming regenerative braking power level at 100 - 200 kW, it can be noticed that in
327 case of TS 2 substation 80 - 90% of energy generated during the recuperation can be absorbed
328 by the supply system. In case of TS 9 substation the level of recuperation usage is only 20 -
329 30%.

330 The dependence between density of trolleybus traffic and possibility of generated
331 energy absorption is reflected in characteristic of recuperation effectiveness. In Fig. 9 the
332 value of recuperation effectiveness in function of an average number of vehicles in the supply
333 area of the substation is presented. Effectiveness of recuperation is defined as the rate between
334 the recovered braking energy and the energy consumed by traction drives. Greater number of
335 vehicles in one supply area means higher probability of absorption of the recovered energy.
336 As a result, the recuperation effectiveness increases with the number of vehicles in the supply
337 area. In case of high density of traffic (more than 10 vehicles running) it is possible to recover
338 around 40% of consumed energy, which is very close to the value of recuperation potential
339 estimated in the beginning of this paper.

340

341 **4.3. Energy storage systems**

342 If the generated power is not received, it may be stored in a tray storage system for later
343 use. The supercapacitors storage system are the most popular technology of energy storage. In
344 2009 the PKT began to cooperate with the Traction Department of the Institute of Electronics
345 in Warsaw (IEL) to launch in-service tests of a supercapacitor storage device installed in a
346 traction substation in Gdynia. The device was designed to accumulate energy from
347 regenerative braking. Gdynia storage device was installed in April 2011 in *Pólnocna*
348 trolleybus traction substation. *Pólnocna* is a two-set traction substation which had undergone



349 a complete modernisation in August 2010. The substation is fitted with two sets of rectifiers
350 with a transformer rating of 1200 kVA each and powers 6 supply units. Currently it is the
351 largest traction substation in Gdynia trolleybus network. The electrical capacitance of
352 installed supercapacitor modules is 0.7 kWh.

353 Positive exploitation experience of the energy supercapacitor installed in *Północna*
354 substation gave grounds for the decision to install another supercaps tank, which was located
355 in Wielkopolska traction substation. It is a small substation equipped with one rectifier unit of
356 1200 kV, supplying only one catenary power supply section. It feeds the trolleybus network in
357 a hilly area of Gdynia, where the value of the road gradient reaches 8%. It is the cause of a
358 substantial recovery braking energy generation, which predetermined a supercapacitor
359 installation in this substation.

360 The supercaps tank was launched in 2014. Its energy capacity is 1.5 kWh and it
361 consists of two parts: the converter block is located inside the substation building, whereas the
362 supercondenser modules are placed in the outside container. Fig. 10 shows a comparison of
363 the relative value of energy recovery in vehicles equipped with a regenerative braking system
364 before and after the installation of the supercapacitor energy storage system.

365 Fig. 11 shows the relation between the average number N of the vehicles, which express the
366 density of trolleybus movement on the individual supply sections and the value of recuperated
367 energy consumed by other vehicles $E_{network}$ and recuperated energy stored in supercapacity
368 bank $E_{storage}$ referred to value of energy recuperated by propulsion $E_{recovery}$. At weekdays when
369 trolleybus traffic intensity, which is expressed by the average number of trolleybuses on the
370 power supply area, is at the level of two vehicles, 70% of the recovered energy is absorbed by
371 other vehicles in traffic, and only 20% of this energy is stored in the tank. Thus, the reduction
372 of energy consumption associated with the work of the supercapacitor is as low as 10%. In
373 contrast, during days off work, when the frequency of trolleybus runs is decreased by a half



374 and there is an average of one vehicle on the power supply section, the exploitation of a
375 supercapacitor rises significantly since it accumulates from 50% to 70% of recovered energy.
376 Another issue worth noticing is a variation on an annual basis, which is associated with a
377 variable value of energy consumption for non-traction vehicles needs [9].

378

379 **5. Discussions**

380 There are three ways to re-use the recovered energy: consumption by auxiliaries in the
381 vehicle, consumption by other vehicles and storing energy in storage systems. In the
382 performed analysis the importance of all these three ways was shown.

383 Recuperative energy consumption for the vehicles non-traction purposes is the most
384 effective form of energy recovery use, thus the on-board equipment should be constructed in
385 such a way that it is firstly supplied with recuperation energy. This can be achieved by e.g.
386 introducing power modulation of heating units; the power of heaters can be raised during
387 regenerative braking and reduced while driving, which will allow for an increase in the share
388 of recuperation energy in heating the vehicle. As it is presented in Fig. 7, in case of intelligent
389 power modulation of heating unit during winter season it is possible to consume most of the
390 recuperated energy. It allows to significantly reduce the load of supply system and reduce the
391 transmission losses.

392 Utilization of the recuperated energy inside vehicles plays an important role in reducing
393 the energy consumption. Nevertheless, even in winter season there is no possibility to
394 consume all recuperated energy by auxiliaries. Furthermore, in spring or autumn season the
395 use of the recuperated energy by auxiliaries drops to 20-30% (Fig. 6), therefore it is necessary
396 to return back the recuperated energy to DC supply system, which was the second tested
397 element of the energy balance. As research has shown in a classic supply system (without
398 supercapacitors) it is possible to use most of recuperation energy by vehicles in motion (Fig.



399 11). In the case of high traffic density, the level of recuperation efficiency reaches 40%,
400 which is the maximal possible technical level of breaking energy recuperation. It can be
401 concluded, that almost all generated energy can be consumed on the way vehicle - a vehicle.
402 This is important especially in the realities of Central Europe, where the central power
403 systems with large traction substations and extensive areas of power are predominant. The
404 failure of energy usage occurs in case of energy supply areas with low traffic intensity.
405 Therefore, solutions facilitating the flow of recuperation energy between vehicles and
406 extending galvanically connected traction network areas should be applied. It can be achieved
407 by, for example, introducing a bilateral power supply system. It can be concluded that dense
408 division of a supply system into small, galvanically isolated supply areas is not recommended,
409 because it impedes an exchange of the recovered energy between the vehicles. Therefore,
410 designing a supply system facilitating the flow of recovered energy should be treated as a
411 priority. Creating the largest possible areas of a galvanically connected contact system is also
412 highly recommended. Supply areas should be enlarged by connecting together areas of
413 neighboring substations by bi-directional supply of the contact network. This will allow the
414 flow of recovered energy between supply areas of different substations. Moreover, in order to
415 facilitate energy flow between the supply sections, the neighboring sections can be joined.
416 Voltage losses in the DC supply system limit the flow of the recovered energy. The efficiency
417 of recuperation and recovered energy transfer can be improved by the reduction of no-load
418 voltage of the substation. Lowering the no-load voltage by 20 V brings a decrease of energy
419 consumption of 3% [35].

420 In case of small traction substation supplying only one or two supply sections at the same
421 time only one or two vehicles occur in the supply section. This low number of vehicles makes
422 it difficult to exchange recovered energy between vehicles and the efficiency of energy
423 recuperation drops under 20%, what is seen in case of TS9 and T10 in Fig. 3 and 8. Therefore



424 application of the supercapacitor is most efficient at low intensity traffic or in a hilly area.
425 Supercapacitors ought to be used as complementary to the power system where generation of
426 recuperation energy is significant or where reconfiguration of the network power supply
427 system is not viable. The effectiveness of SC storage system operation is also high at low
428 intensity traffic. However, in this case the total amount of energy saved in the tray is small,
429 because despite the high relative value of the reduction of energy consumption installation of
430 SC storage system may be unprofitable.

431 We should also emphasize the practical importance of the method of estimating the
432 potential recovery, which was presented in chapter 4.2, (2) - (4) . It is possible to yield
433 measurement data to assess the current utilization of recuperation easily (Fig. 8).

434

435 **6. Conclusions**

436 Table 1 presents comparisons of the discussed methods. Unused energy is the cheapest
437 form of energy. Recuperation of braking energy allows to reduce the energy losses in braking
438 resistors. As a result, total energy consumption decreases. In the paper the authors have shown
439 practical aspects of increasing of breaking energy recovery in public transport.

440 The main novelty of the presented method is a combination of measurements of the
441 geographic parameters (GPS) with electrical ones (voltage and current of drive system). This
442 allows the energy consumption analysis in terms of geography characteristic. Thanks to this
443 factors that affect the energy consumption at the local level are taken into account.

444 The aim of the conducted study was to present the results of experiences of PKT Gdynia
445 in the field of energy consumption reduction. The solutions applied in Gdynia may be “ready
446 to use” solutions for other transport companies. Moreover, the article highlights the impact
447 practical verification of energy reduction methods in electrified transport. Analysis which are
448 based on real measurements are more reliable for practical applications than theoretical



449 simulation and analysis. This presented measurement methods perfectly complement the
450 existing theoretical state of art. As the result, the practical impact of the article increases and
451 presented results of the research can be applied in wider range.

452

453 **Acknowledgment**

454 This paper has been elaborated in the framework of the project ELIPTIC co-financed by the
455 European Union's Horizon 2020 research and innovation programme under the grant
456 agreement No 636012

457

458 [1] M.C. Falvoa, R. Lamedica, R. Bartoni, G. Maranzano, *Energy management in metro-*
459 *transit systems: an innovative proposal toward an integrated and sus-tainable urban mobility*
460 *system including plug-in electric vehicles*, *Electric Power Systems Research* 81 (2011) 2127–
461 2138.

462 [2] C. Wang, W.J. Cai, X.D. Lu, J.N. Chen. *CO2 mitigation scenarios in China's road*
463 *transport sector*. *Energy Conversion and Management* 2007, 48(7), pp. 2110–8.

464 [3] R. Kuhne, *Electric buses, an energy efficient urban transportation means*, *Energy* 35
465 (2010) 4510-4513

466 [4] S. Scarpellini, A. Valero, E. Llera, A. Aranda, *Multicriteria analysis for the assessment*
467 *of energy innovations in the transport sector*, *Energy* 57 (2013)160–168.

468 [5] B. Peng, H. Dua, S. Maa, Y. Fan, D. Broadstock, *Urban passenger transport energy*
469 *saving and emission reduction potential: A case study for Tianjin, China*, *Energy Conversion*
470 *and Management* 102 (2015) 4–16

471 [6] A. Das, J. Parikh, *Transport scenarios in two metropolitan cities in India: Delhi and*
472 *Mumbai*. *Energy Conversion and Management* 2004, 45(15) pp. 2603–25.

473 [7] M. Połom, M. Bartłomiejczyk, *Trolleybuses in the city of Gdynia*, A historical and
474 geographical study, in: Bartłomiejczyk M., Połom M. (ed.), *Determinants of functioning of*

- 475 trolleybus transport in selected cities of the European Union, Wydawnictwo Bernardinum,
476 Pelplin, 2011., s. 119-139.
- 477 [8] A.G. Olabi, *100% sustainable energy*, Energy, Volume 77, 1 December 2014, Pages
478 1-5
- 479 [9] A. A. Usón, A. V. Capilla, I. Z. Bribián, S. Scarpellini, E. L. Sastresa, *Energy*
480 *efficiency in transport and mobility from an eco-efficiency viewpoint*, Volume 36, Issue 4,
481 April 2011, Pages 1916–1923
- 482 [10] C. Weiller, A. Neely, *Using electric vehicles for energy services: Industry*
483 *perspectives*, Energy, Volume 77, 1 December 2014, Pages 194-200,
- 484 [11] M. D.Galus , M. Zima, G. Andersson, *On integration of plug-in hybrid electric*
485 *vehicles into existing power system structures*, Energy Policy 38 (2010) 6736–6745
- 486 [12] X. Feng, B. Mao, X. Feng, J. Feng, *Study on the maximum operation speeds of metro*
487 *trains for energy saving as well as transport efficiency improvement*, Energy, Volume 36,
488 Issue 11, November 2011, Pages 6577-6582
- 489 [13] R. Ramakrishnan, Somashekhar S. Hiremath, M. Singaperumal, *Design strategy for*
490 *improving the energy efficiency in series hydraulic/electric synergy system*, Energy, Volume
491 67, 1 April 2014, Pages 422-434
- 492 [14] R. Chicurel, *A compromise solution for energy recovery in vehicle braking*,
493 Energy, Volume 24, Issue 12, January 1999, Pages 1029-1034
- 494 [15] V. Musolino, A. Pievatolo, E. Tironi, *A statistical approach to electrical storage*
495 *sizing with application to the recovery of braking energy*, Energy, Volume 36, Issue 11,
496 November 2011, Pages 6697-6704
- 497 [16] C.M. Jefferson, M. Ackerman, *A flywheel variator energy storage system*. Energy
498 Conversion and Management 1996, 37, pp.1481–91.



- 499 [17] P. Sharma, T.S. Bhatti, *A review on electrochemical double-layer capacitors*. Energy
500 Conversion and Management 2010, 51 pp. 2901–12.
- 501 [18] V. Herrera, H. Gaztanaga, A. Milo, A. Saez-de-Ibarra; I. Etxeberria; T. Nieva, *Optimal*
502 *Energy Management of Battery-Supercapacitor based Light Rail Vehivle using Genetic*
503 *Algorithms*, IEEE Transactions on Industry Applications, Year: 2016, Volume: PP, Issue: 99,
504 Pages: 1 - 1, DOI: 10.1109/TIA.2016.2555790
- 505 [19] R. Teymourfar, B. Asaei, H. Iman-Eini, R. Nejati. *Stationary super-capacitor energy*
506 *storage system to save regenerative braking energy in a metro line*. Energy Conversion and
507 Managment 2012, 56, pp. 206–14.
- 508 [20] F. Ciccarelli, D. Iannuzzi; K. Kondo; L. Fratelli L. *Line-Voltage Control Based on*
509 *Wayside Energy Storage Systems for Tramway Networks*, IEEE Transactions on Power
510 Electronics, Year: 2016, Volume: 31, Issue: 1, Pages: 884 -
511 899, DOI: 10.1109/TPEL.2015.2411996
- 512 [21] R. Barrero, X. Tackoen, J. V. Mierlo, *Improving energy efficiency in public transport:*
513 *stationary supercapacitor based energy storage systems for a metro Network*, IEEE Vehicle
514 Power and Propulsion Conference (VPPC), September 3-5, 2008, Harbin, China
- 515 [22] A. Gonzalez-Gil, R. Palacin, P. Batty. *A systems approach to reduce urban rail energy*
516 *consumption*, Energy Conversion and Management Volume: 80 Pages: 509-52
- 517 [23] B. Destraz, P. Barrade, and A. Rufer, Klohr, “Study and simulation of the energy
518 balance of an urban transportation network,” in Proc. European Conf. Power Electronics and
519 Applications 2007 (EPE 2007), Aalborg, 2007
- 520 [24] A. Gonzalez-Gil, R. Palacin, P. Batty, *Optimal energy management of urban rail*
521 *systems: Key performance indicators*, Energy Conversion and Management Volume: 90
522 Pages: 282-291



- 523 [25] A. Gonzalez-Gil; R. Palacin; P. Batty, *Sustainable urban rail systems: Strategies and*
524 *technologies for optimal management of regenerative braking energy*, Energy Conversion and
525 Management Volume: 75 Pages: 374-388 Published: NOV 2013
- 526 [26] J. Kubín, *Influence of external condition on tram energy consumption*, VLIII. Sešit
527 Katedry Elektrotechniky, VŠB Ostrava, Ostrava, 2014 (in Czech)
- 528 [27] M. Ceraolo; R. Giglioli; G. Lutzemberger; A. Bechini, *Cost effective storage for*
529 *energy saving in feeding systems of tramways*, Electric Vehicle Conference (IEVC), 2014
530 IEEE International, Year: 2014, Pages: 1 - 6, DOI: 10.1109/IEVC.2014.7056112
- 531 [28] Z. Gizinski; M. Gasiewski; I. Mascibrodzki; M. Zych; K. Zymmer; M. Zulawnik,
532 Hybrid - type system of power supply for a trolleybus with an asynchronous motor, Power
533 Electronics and Motion Control Conference, 2008. EPE-PEMC 2008. 13th, Year: 2008, pp:
534 1562 - 156
- 535 [29] S. Hamacek, M. Bartłomiejczyk, R. Hrbac, S. Misak, V. Styskala, *Energy recovery*
536 *effectiveness in trolleybus transport*, Electric Power Systems Research 112 (2014) 1–11.
- 537 [30] M. Bartłomiejczyk, *Use of Numerical Methods in the Analysis of Traction Energy*
538 *Systems—An Overview of the Practical Examples*, Proceedings of the First International
539 Scientific Conference "Intelligent Information Technologies for Industry" (IITI'16) Volume
540 451 of the series Advances in Intelligent Systems and Computing pp 407-418
- 541 [31] M. Bartłomiejczyk, S. Mirchevski, *Reducing of energy consumption in public*
542 *transport — Results of experimental exploitation of super capacitor energy bank in Gdynia*
543 *trolleybus system*, Power Electronics and Motion Control Conference and Exposition
544 (PEMC), 2014 16th International, 10.1109/EPEPEMC.2014.6980616.
- 545 [32] L. Jarzebowicz, *Sensorless IPMSM drive with rotor position estimator based on*
546 *analysis of phase current derivatives*, Proc. of 2011 IEEE International Symposium on
547 Industrial Electronics (ISIE), 2011, pp. 733–738. DOI: 10.1109/ISIE.2011.5984248.



548 [33] R. Hrbáč, V. Kolář, T. Mlčák: *Distributed measurement system with GPS*
549 *synchronisation and its use in electric traction*. Elektronika ir elektrotechnika, Kaunas
550 university of technology, Kaunas, Lithuania. Volume: 21/2015, Issue: 6, pp. 8-13. ISSN:
551 1392-1215.

552 [34] S.C. Hu, J.H. Lee, *Influence of platform screen doors on energy consumption of the*
553 *environment control system of a mass rapid transit system: case study of the Taipei MRT*
554 *system*. Energy Conversion and Management 2004, 45, pp. 639–50.

555 [35] Bo-Chih Peng; Nanming Chen, *Energy saving strategies in Mass Rapid Transit*
556 *systems*, Connected Vehicles and Expo (ICCVE), 2014 International Conference on Year:
557 2014 Pages: 272 - 277

558

559 **Provides:**

560 **Figure. 1.** Graph of changes the relative share of the number of vehicles driven power
561 electronics k and the average consumed energy E on a scale of years 2002-2013.

562 **Figure. 2.** Braking energy low flow in vehicle, U_{CN} – voltage of contact supply network, E_k
563 kinetic energy of vehicle, TM – traction motor, TC – traction controller, BC – braking
564 controller, RH – braking resistor

565 **Figure. 3.** Energy consumption for traction needs, energy recovery and energy dissipated
566 (lost) in braking resistors in several supply areas of traction substations in Gdynia

567 **Figure. 4.** The load flow of the recovered energy by traction propulsion, which can be
568 consumed by auxiliary needs, other vehicles running in network or can be store in
569 supercapacitor energy bank.

570 **Figure. 5.** The scheme of measurement system, the points of measurements are shown: (1)
571 supply section load, (2) storage energy bank load, (3) vehicles load. GPS coordination allows
572 to analyze load of vehicles in particular supply section.



573 **Figure. 6.** Relative amount k of recuperation energy consumed by non traction needs in the
574 vehicles needs (related to total energy consumption in scale of all trolleybus transport system)
575 in one year scale from January to December. The average one-day values are shown.

576 **Figure. 7.** The difference between recovered energy consumption for auxiliary needs in a
577 vehicle with the standard heating system and the intelligent heating system

578 **Figure. 8.** Relative usage of recuperated energy in function of value of recuperation power for
579 two substations: TS 2 and TS 9.

580 **Figure. 9.** Recuperation effectiveness in function of average number of vehicles in the supply
581 area of the substation.

582 **Figure. 10.** shows a comparison of the relative value of energy recovery in vehicles equipped
583 with a regenerative braking system before and after the installation of the supercapacitor
584 energy storage system.

585 **Figure. 11.** Relation between the average number N of the vehicles, which express the density
586 of trolleybus movement on the individual supply sections and the value of recuperated energy
587 consumed by other vehicles $E_{network}$ and recuperated energy stored in supercapacity bank
588 $E_{storage}$ referred to value of energy recuperated by propulsion $E_{recovery}$

589 **Table 1.** Comparison of methods of increasing the efficiency of recuperation

Table 1. Comparison of methods of increasing the efficiency of recuperation

<i>Use of recuperation energy</i>	<i>Method of increasing recuperation</i>	<i>Energy savings</i>
Recovered energy consumption in a vehicle	Implementation of an "intelligent" heating	3 - 10%
Transfer of recovered energy between vehicles	Implementation of bilateral supply of traction network	5 - 15%
	Splitting the neighboring supply sections	1 - 5%
	Reducing of no-load substation voltage	1 - 5%
Accumulation of recovered energy	Use of the energy storage systems	5 - 30%

Figure 1
[Click here to download high resolution image](#)

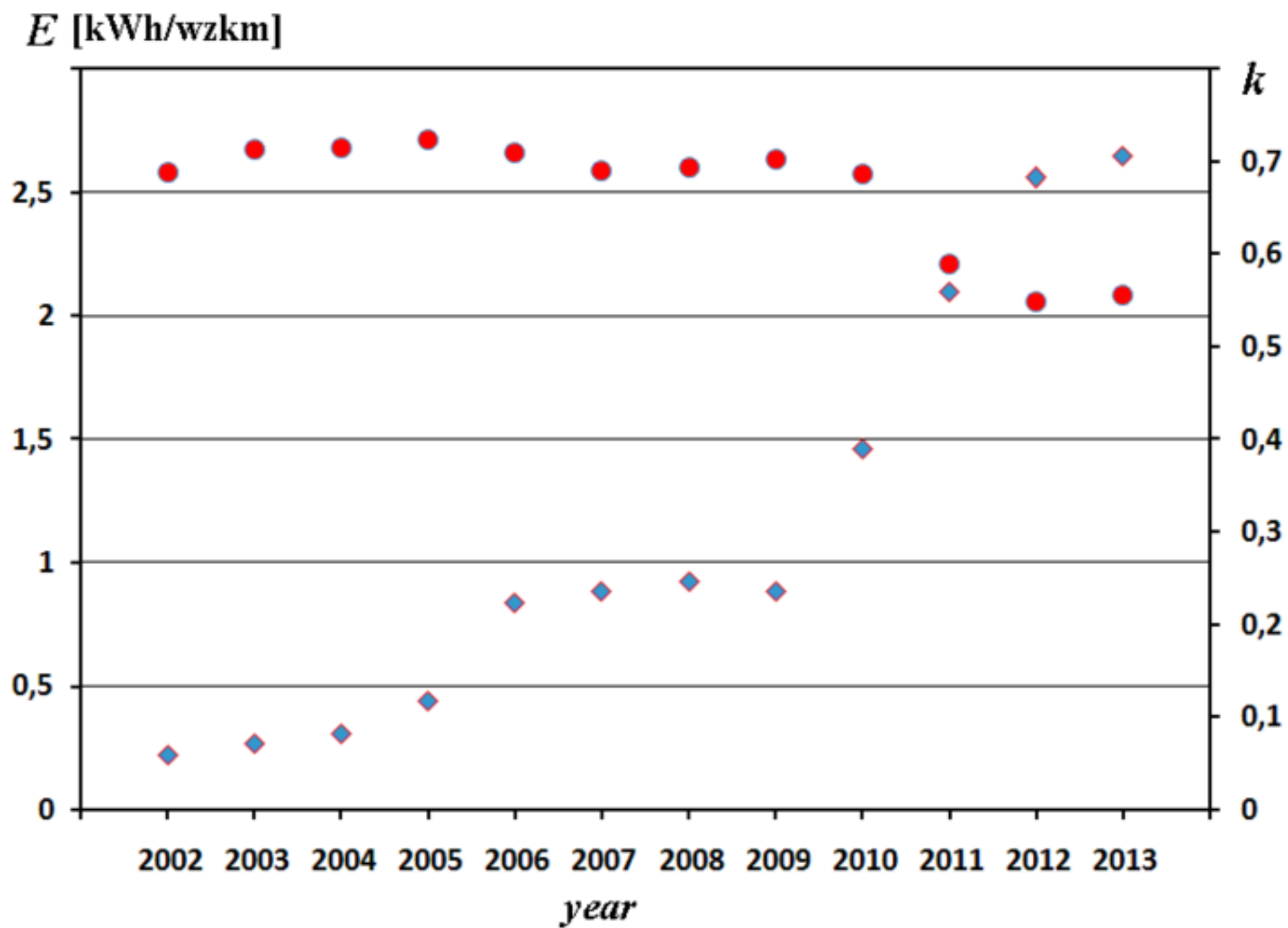

Figure 2
[Click here to download high resolution image](#)

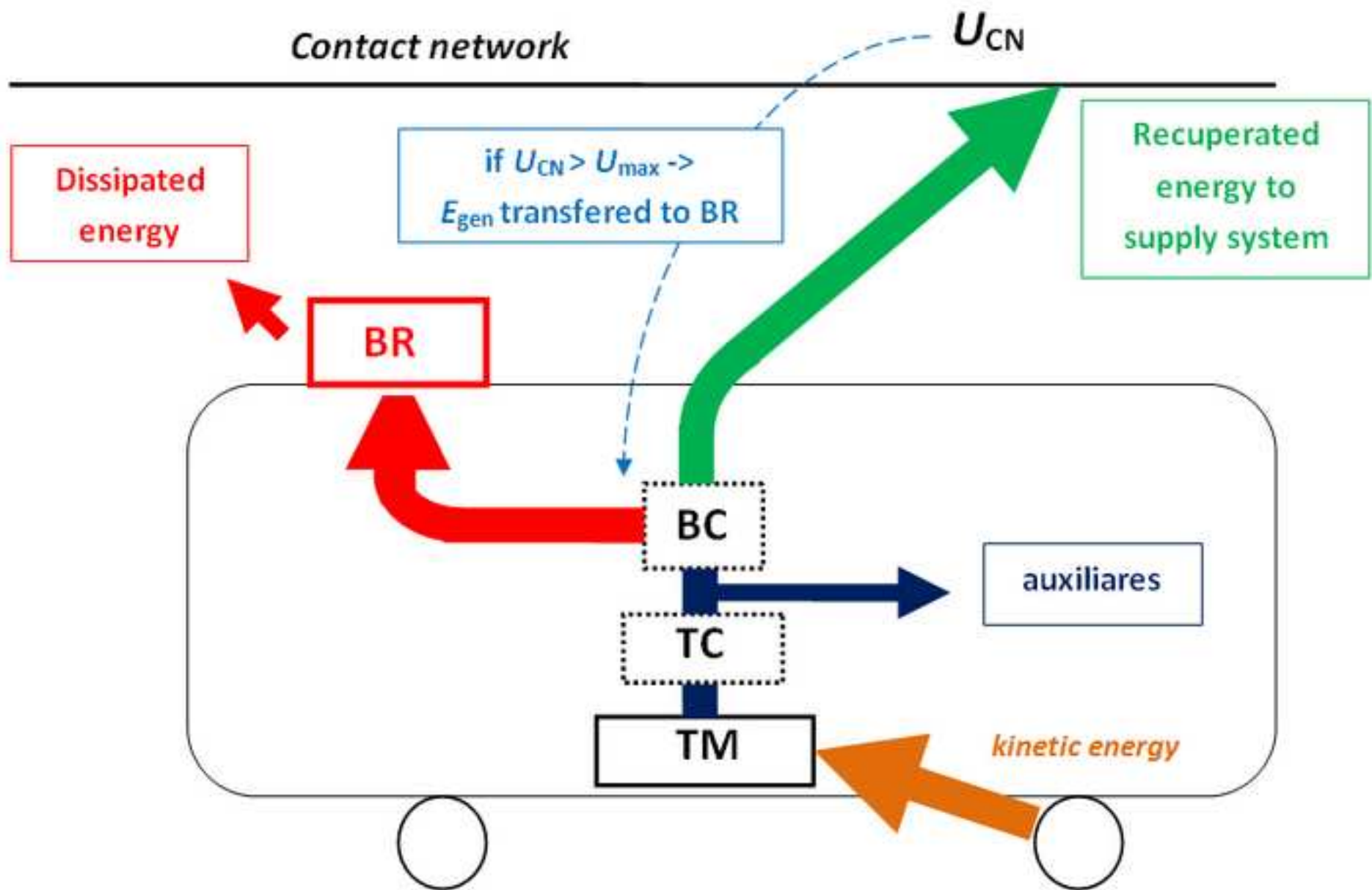

Figure 3
[Click here to download high resolution image](#)

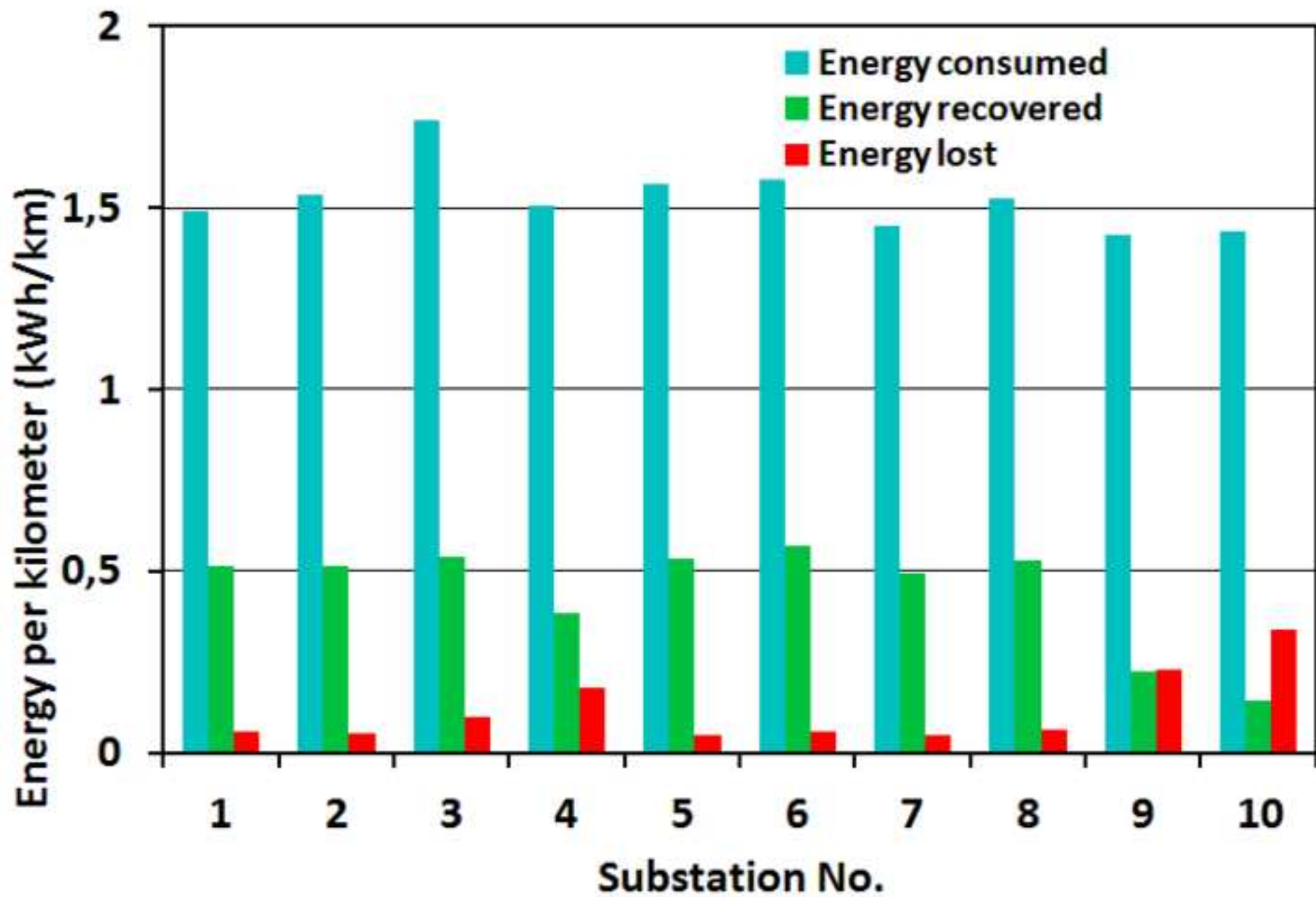

Figure 4
[Click here to download high resolution image](#)

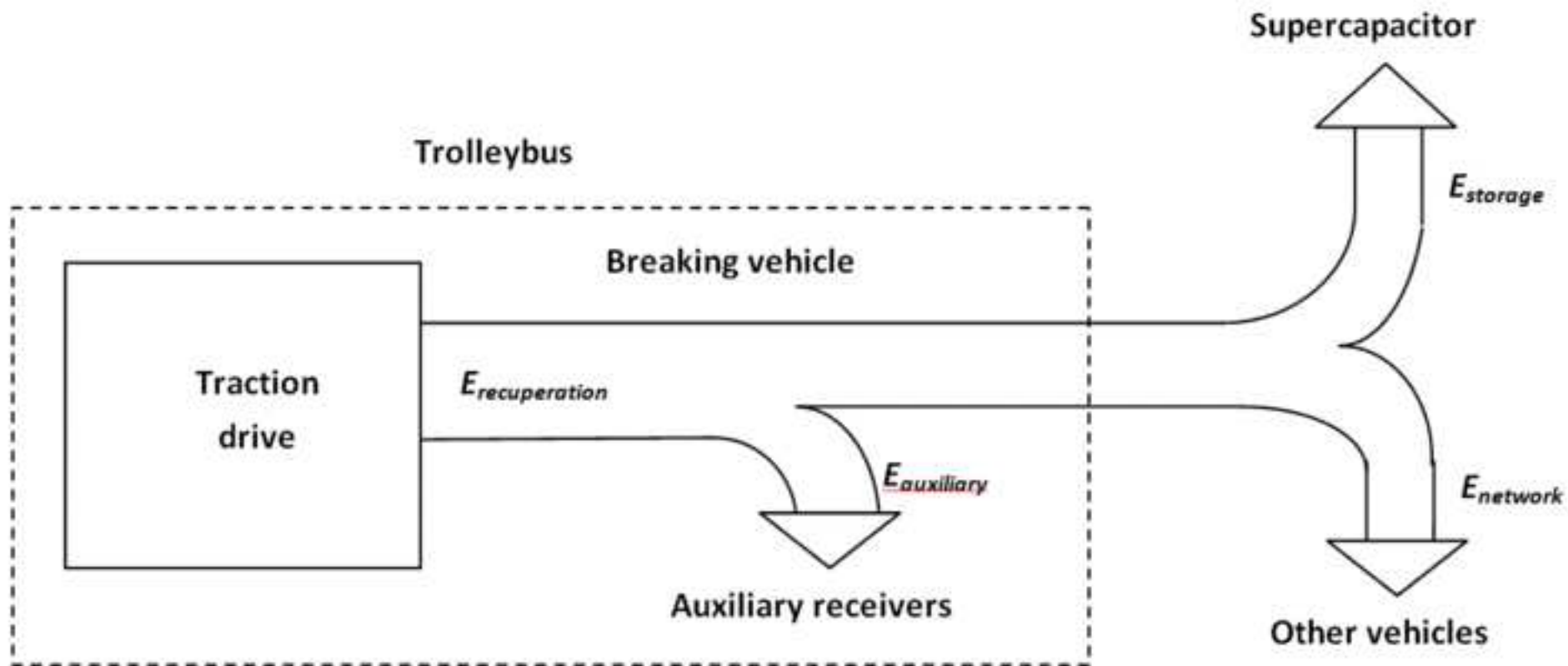

Figure 5
[Click here to download high resolution image](#)

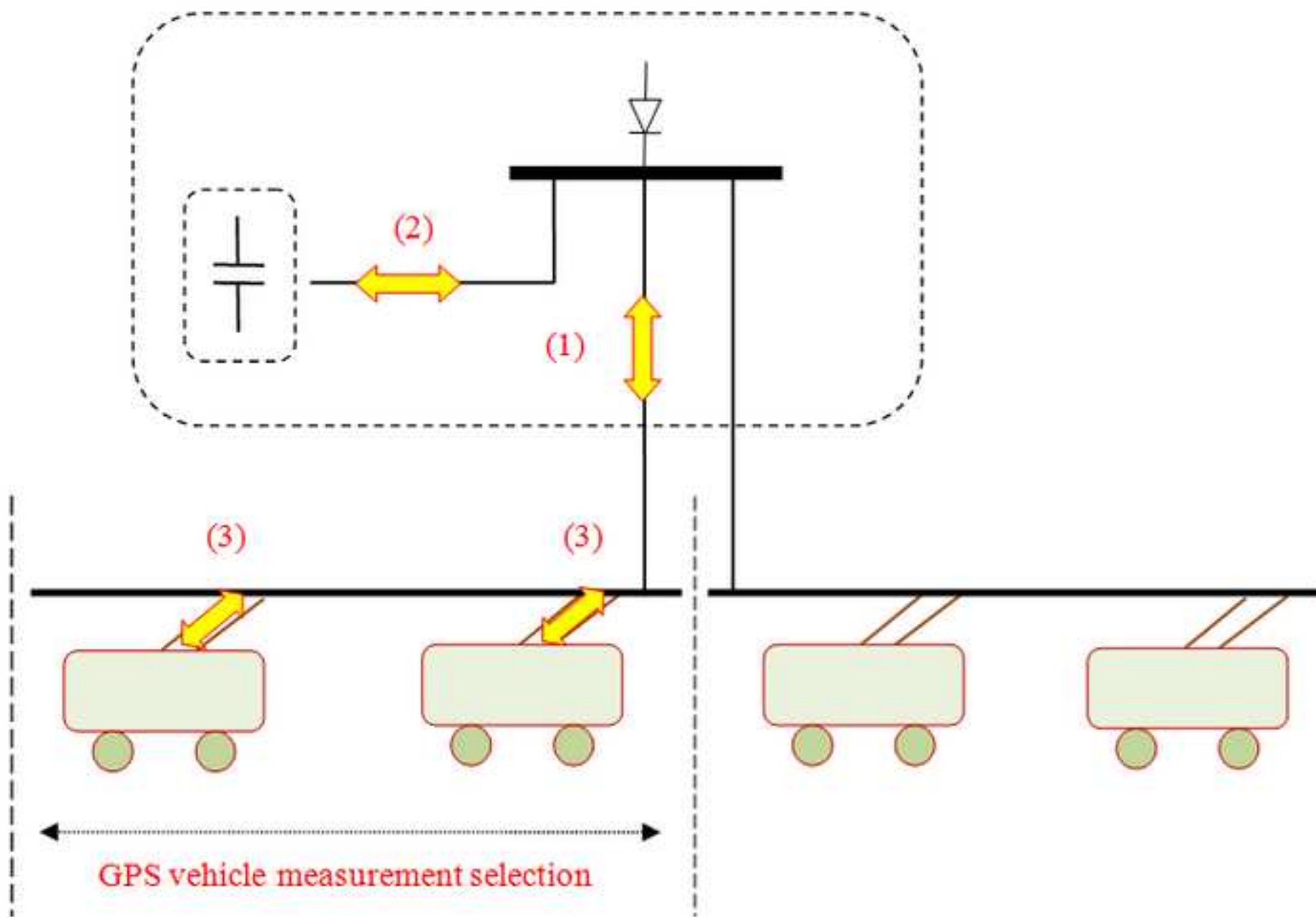

Figure 6
[Click here to download high resolution image](#)

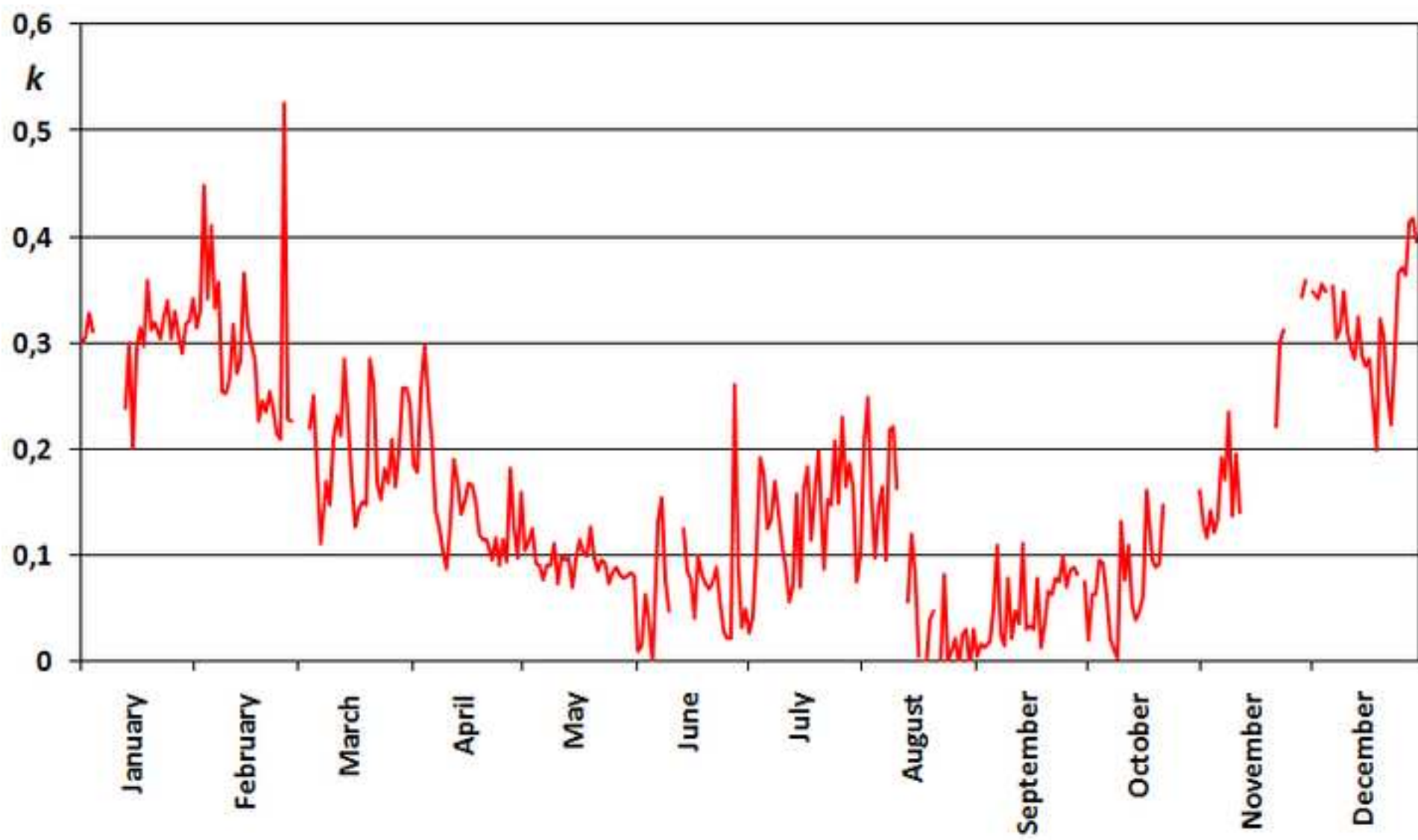

Figure 7
[Click here to download high resolution image](#)

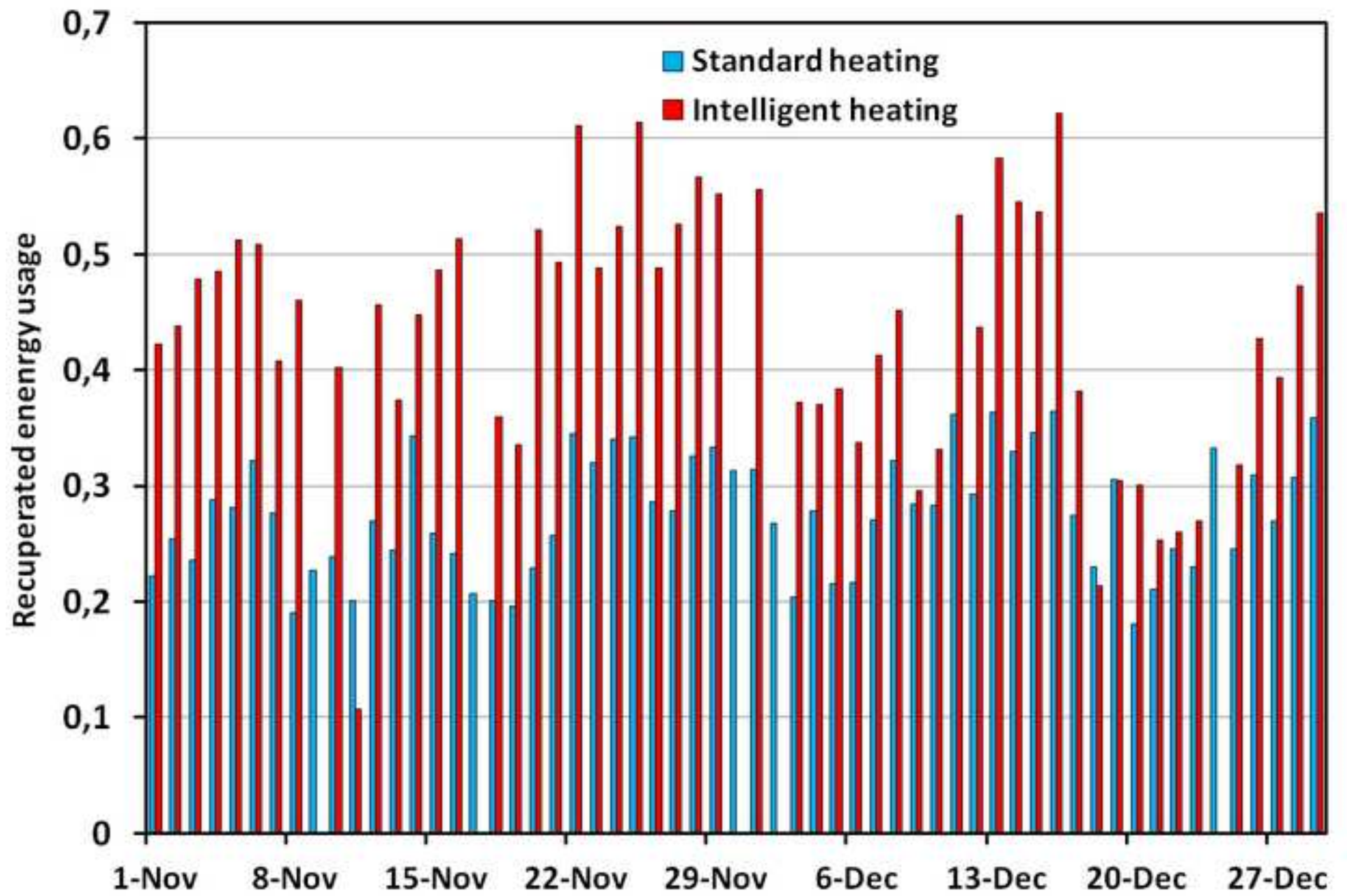

Figure 8
[Click here to download high resolution image](#)

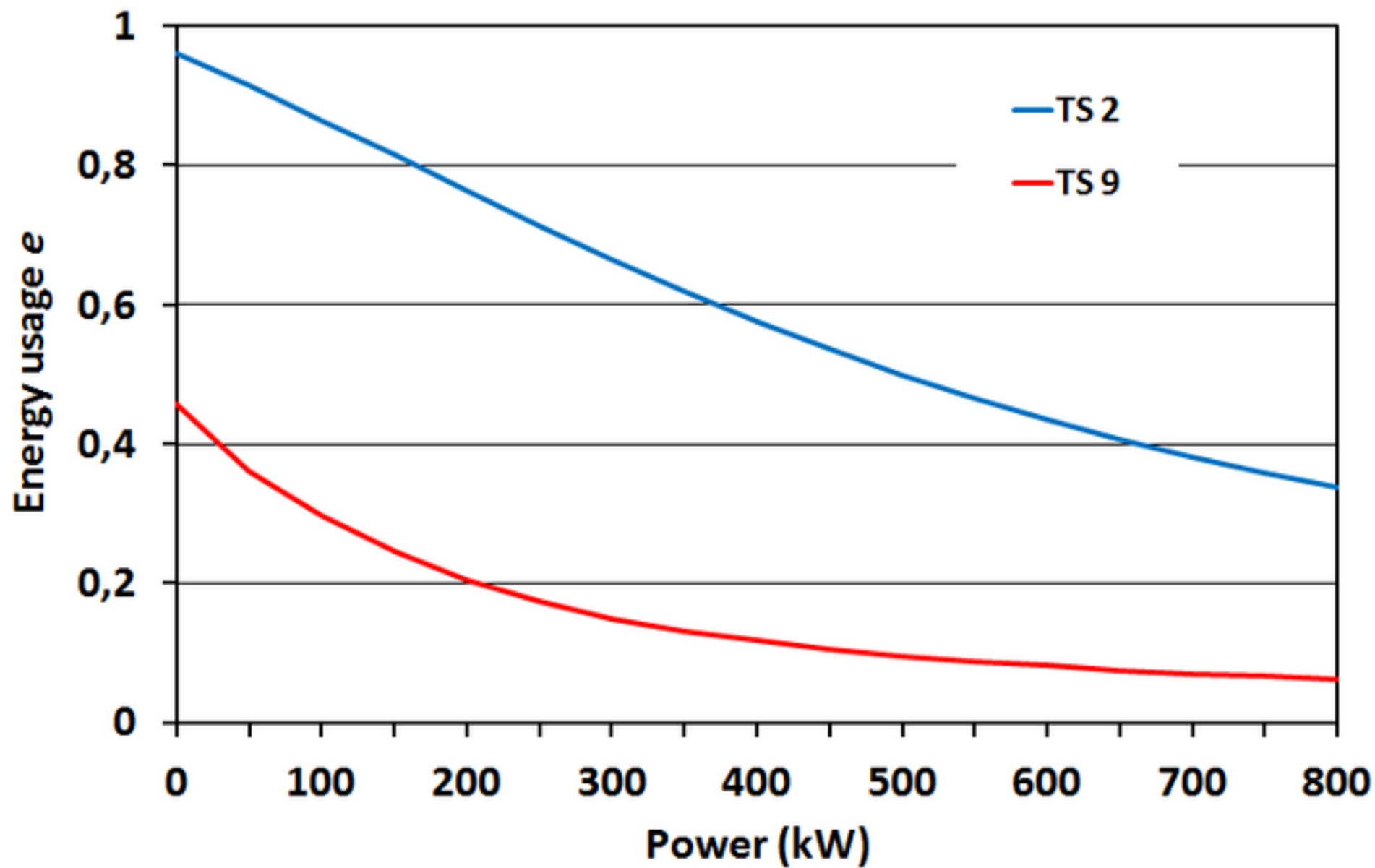

Figure 9
[Click here to download high resolution image](#)

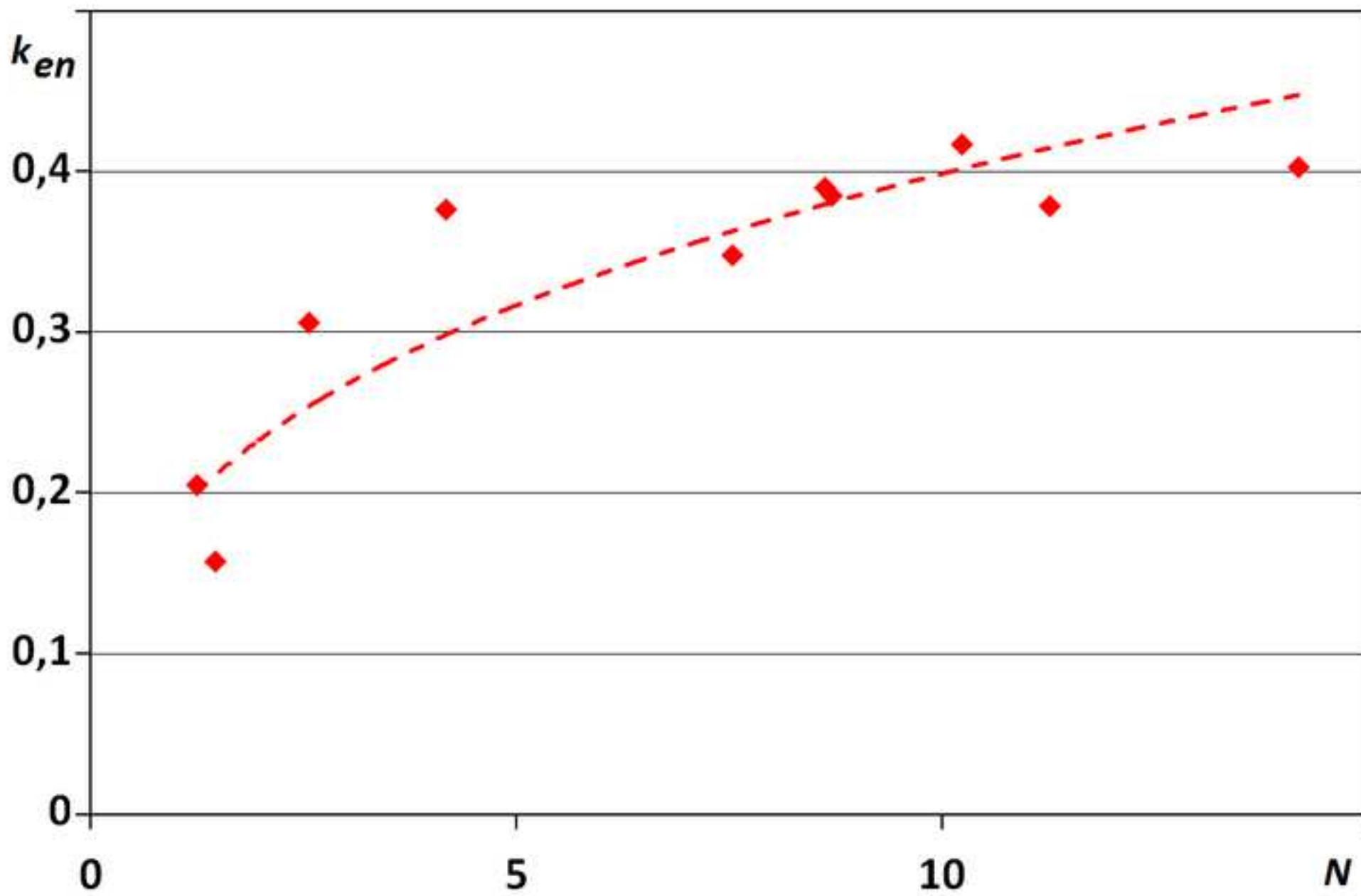

Figure 10
[Click here to download high resolution image](#)

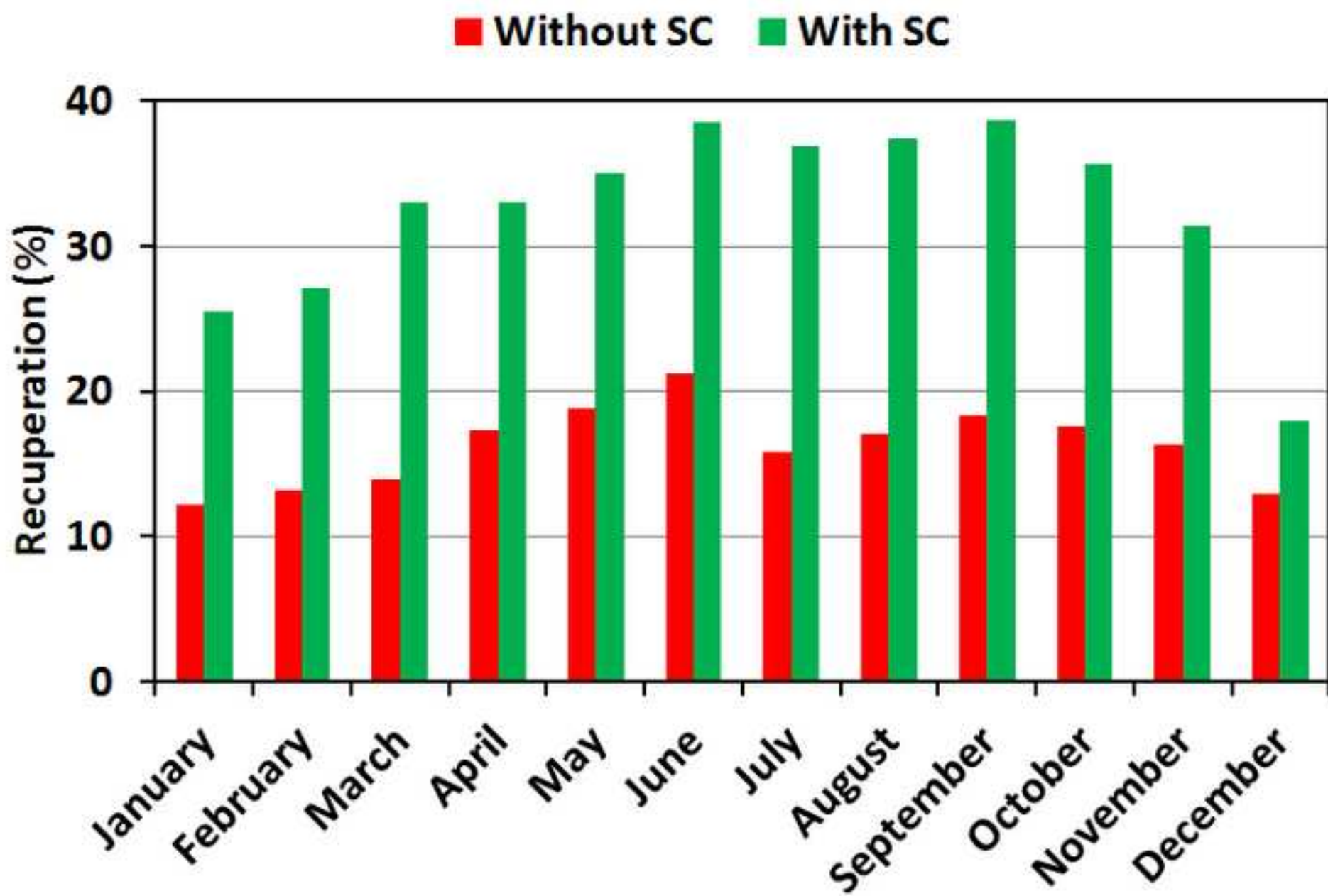

Figure 11
[Click here to download high resolution image](#)

