

Key words:
speech, DSP, stuttering

Piotr ODYA, Andrzej CZYŻEWSKI*

NEW GENERATION SPEECH AID FOR STUTTERING PEOPLE

Modern Digital Signal Processors (DSP) may have small dimensions and very low current consumption, but they are able to execute complex algorithms. In addition, they can be easily reprogrammed using a standard PC computer. Taking advantage of these processors, it was possible to build a device, which can be used either as a speech aid or a hearing aid, or both. The paper placed emphasis on issues related to the implementation of algorithms applicable to speech aids. For example, spectral compression or delaying the audio signal are often used for speech fluency improvement, thus they are shortly reviewed in the paper. Some additional algorithms which can improve the quality of the audio signal are also described. Clinical tests proved that the SDSA improves speech fluency. A detailed description of tests carried out and of their results is included in the paper.

1. INTRODUCTION

There are many theories concerning stuttering causes [8] [12] [13]. Following the successful introduction of the first compact digital anti-stuttering device [1] long-term research studies were carried out in the Multimedia Systems Department and in the International Centre of Hearing and Speech of the Institute of Physiology and Pathology of Hearing. The results of this study prove that the main reason of stuttering should be sought within the auditory feedback loop disorders. Moreover, it was confirmed empirically that by introducing some changes into the auditory feedback loop a serious reduction of stuttering may be achieved. Even though the background of this phenomenon was not explained yet, alterations to the auditory feedback loop were being introduced for many years. There are various methods existing of changing speech in the auditory feedback loop. All this methods change the way a patient perceives her or his own speech. The most popular methods are DAF (Delayed Auditory feedback) and FAF (Frequency Altered Feedback) [2] [4] [5].

* Gdańsk University of Technology, G. Narutowicza 11/12, 80-952 Gdańsk and Institute of Physiology and Pathology of Hearing, Zgrupowania AK Kampinos 1, 01-942 Warsaw

2. TESTING THE DSA

The first stage of this study was to assess various speech correction algorithms and their efficiency. For this purpose the Digital Speech Aid (DSA) has been employed. As mentioned before, the DSA was designed in early 90s at the Gdansk University of Technology in co-operation with the Canadian Dalhousie University. The DSA has dimensions of a cigarette package and requires the use of external microphone and headphones [1] [2] [8]. The DSA allows using the DAF and FAF methods simultaneously or separately. The satisfactory results in clinical trials the Multimedia Systems Department of the Gdansk University of Technology convinced the Foundation for Polish Science to subsidize testing of 100 units of the DSA within the program of supporting pre-commercial works on new technologies, products and services. In this way, 100 devices were under examination in selected psychological-pedagogical centres in various locations in Poland. Comprehensive assessments of the efficacy of the therapy using DSA have been carried out using questionnaires and a so-called “syllable test” [10] [11].

128 patients took part in the experiments, most of them were school age children. 75% of patients were boys – this confirms numerous observations that males more often stutter than females. Merely 30% of patients had a stuttering person in a family, this indicates that there is no direct relationship between stuttering and familial inheritance patterns.

In-depth analysis of results obtained from the Centres, performed in the Statistica software, showed that improvement of total fluency was observed in above 75% of stutterers. Furthermore, in more than 70% cases speech remained fluent even after switching off the DSA. FAF and DAF+FAF methods have been assessed as more efficient than while using the DAF method only (Fig. 1). Also the syllable tests proved the high efficiency of spectral alteration methods. In a case of the FAF method, patients most often have chosen a spectral transposition down the frequency scale which amounted to 6% of the octave.

Based on the recorded patients’ utterances it was possible to perform a thorough speech analysis. Emphasis was placed on observation of a vocal tone frequency, and formant frequencies and their amplitudes. Modified cepstral analysis was performed, employing methods developed in the Multimedia Systems Department [2] [7] [8] [9].

The analysis has been performed on recordings sent from the psychological-pedagogical centres. The analysis showed that the FAF method causes significant ($p < 0.07$, independent t-test) rising in the vocal tone frequency. This phenomenon is caused by attempts at compensating for the perceived pitch-shift [3]. The DAF methods caused lowering the vocal tone frequency as a result of muscle tension reducing while talking with the DSA. In the case of two methods employed (DAF+FAF), significant changes were not observed. Probably, adding some delay resulted in reducing correlation between articulated and perceived speech and the compensation did not

occur. Changes in the formants frequency and amplitude were not significant and they could not be generalized.

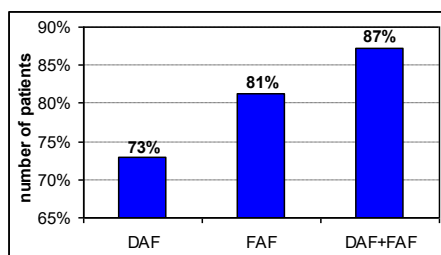

Fig. 1. Number of patients who have noticed speech fluency improvement

The tests indicated also that some improvements in the DSA construction should be introduced. For example many patients were embarrassed to use the DSA because of its visible casing and earphones. That is why it was decided to develop a new version, the Subminiature Digital Speech Aid (SDSA).

3. SDSA PROTOTYPE

A prototype of the new version of the device (SDSA) has been built that should provide a comfort to stutters and - at the same time - it is easy to operate. The SDSA has size of a regular ear-canal hearing aid. Consequently, the patients can easily use it in everyday situations. Interlocutors might not even realize their conversation partner uses a speech corrector. While using the SDSA only one headphone is required. It means that the altered speech is provided only to one ear. It is possible since in most cases there exists a dominant ear in stuttering person, to which the altered sound could be provided. The second ear can receive non-altered sounds, which helps to perceive the interlocutor's speech.

The Toccata Plus digital signal processor was chosen as a core part of the device engineered. The main advantages of the Toccata processor are: low power consumption (typically about 400 μ A at 1.28MHz clock), small size (5.97x3.48x1.52 mm with built-in EEPROM) and programming flexibility (it can be easily reprogrammed using a PC computer). Typical applications of the Toccata processor are hearing aids, but since it is programmable, it can be used in various applications. The block diagram of the SDSA is presented in Fig. 2, and the prototype in Fig. 3.

The SDSA implements some well-known auditory feedback loop signal processing algorithms, such as delaying (DAF) or frequency altering (FAF) speech signal, but also enables to use combination of these methods (DAF and FAF, FAF-to-DAF morphing). Moreover, new algorithms such as: reverb or delay modulation, not used



before in the anti-stuttering devices, have been implemented on this processor. Some additional algorithms for sound enhancement are also utilized, e.g. dynamic processor, equalizer (16 bands), battery monitor and voice key. The aforementioned algorithm was well tolerated by the stuttering person, especially that it causes the SDSA to operate only when the person is speaking, which is very desirable in every day usage.

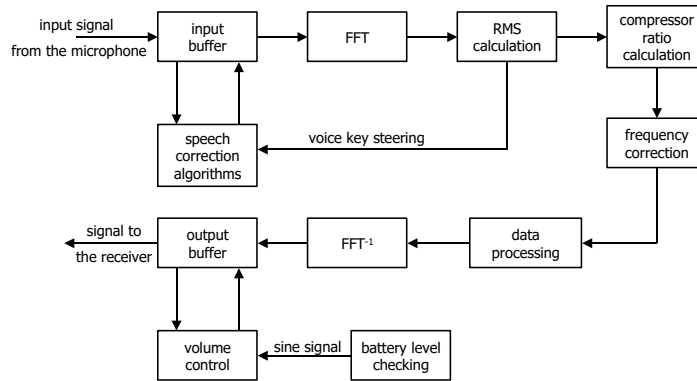

Fig. 2. Block diagram of the SDSA



Fig. 3. Prototype of the SDSA

Algorithms and their parameters can be changed according to patients needs employing special software. The software work under Microsoft Windows based operating systems was developed (along with an appropriate PC interface) within the framework of the project [8].

3.2. TEST SERIES

Three male patients took part in the tests. They were asked to read some short texts excerpts (about 200 syllables, taken from colloquial language, e.g. newspapers) with and without the SDSA and speech correction. All speech disfluency occurrences were counted and then the relative error was calculated as the ratio of the number of disfluency occurrences to the number of syllables.

The algorithms parameters were as follows: DAF – delay 70ms; FAF – 6% octave transposition down the frequency scale; DAF+FAF – delay 70ms, 6% octave transposition down the frequency scale; reverb algorithm – reflection times: 85 and 103ms; delay modulation I – period: 2s, average delay: 64ms, delay range: +/-40ms, modula-

tion function: sinusoidal; delay modulation II – period: 3.2s, average delay: 50ms, delay range: +/-30ms, modulation function: sinusoidal and saw wave combination; FAF-to-DAF morphing – delay 70ms, 6% octave transposition down the frequency scale.

All the methods tested turned out to be efficient and most of them improved speech fluency significantly. The most efficient methods are DAF+FAF, FAF into DAF and delay modulation II (Fig. 4).

Similarly to the preliminary tests with the DSA, speech analyses have been carried out. The results indicated that there are significant differences in a vocal tone frequency in comparison to the DSA. First of all, the vocal tone frequency changes depended more on a patient than the alteration method used. This is caused by the fact that the second ear receives unprocessed sounds. This means that even though changes to the auditory feedback loop are introduced and as a result speech fluency is observed, but the vocal tone frequency changes are of individual nature and depend on a patient.

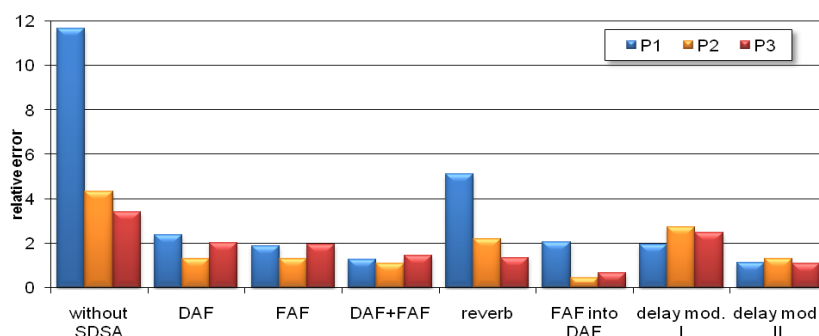

Fig. 4. Efficiency of various speech correction methods

4. CONCLUSIONS

Contemporary signal processors can be used to build sophisticated subminiature speech aids. Clinical tests proved that the SDSA improves speech fluency significantly. Some methods employing speech spectrum modifications in the auditory feedback loop have been assessed as the most efficient ones. The effects of the device application are noticeable immediately, i.e. speech fluency improves right after the device is turned on. Furthermore, patients are getting more open to interactions with other persons and their social isolation decreases, as well as their school results improve. It should be remembered that most of the patients were school children, so it is of utmost importance that difficulties in learning should be eliminated in the earliest stage of their education.

REFERENCES

- [1] CZYŻEWSKI A., KOSTEK B., ROLAND-MIESZKOWSKI M., *Digital Speech Aid Based on the Modification of the Auditory Feedback Loop*, Eurospeech '93, 3rd Eurospeech Congress, 21-23 September 1993, Berlin, Germany.
- [2] CZYŻEWSKI A., SKÓRKA P., *Modification of the Auditory Feedback Loop - Effects on Hearing and Speech Production*, 100th AES Convention, Preprint No. 4148, 11-14 May 1996, Copenhagen, Denmark.
- [3] DONATH T.M., NATKE U., KALVERAM K.T., *Effects of frequency-shifted auditory feedback on voice F0 contours in syllables*, Journal of Acoustical Society of America, Vol. 111, No. 1, January 2002, 357-366.
- [4] HARRINGTON J., *A Model of Stuttering and the Production of Speech under Delayed Auditory Feedback Conditions*, In: Speech Motor Dynamics in Stuttering, New York, Springer Press, 1987, 353-359.
- [5] HOWELL P., EL-YANIV N., POWELL D.J., *Factors affecting fluency in stutterers when speaking under altered auditory feedback*, In: Speech Motor Dynamics in Stuttering, New York, Springer Press, 1987, 361-369.
- [6] HOWELL P., SACKIN S., WILLIAMS R., *Differential effects of frequency shifted feedback between child and adult stutterers*, Journal of Fluency Disorders, Vol. 24, 1999, 127-136.
- [7] KACZMAREK A., SKÓRKA P., *Investigation of the Pitch of the Vocal Tone for Stuttered Speech*, 102nd AES Convention, Preprint No. 4486, 22-25 March 1997, Munich, Germany.
- [8] ODYA P., *Examination and application of auditory feedback loop modification methods (in Polish)*, Doctoral dissertation, Multimedia Systems Department, Gdańsk University of Technology, Gdańsk 2007.
- [9] ODYA P., CZYŻEWSKI A., *Special Hearing Aid for Stuttering People*, 123rd AES Convention, Preprint No. 7293, 5-8 October 2007, New York, USA.
- [10] ODYA P., *Method of Evaluating the Digital Speech Aid Efficacy (in Polish)*, 10th International Symposium on Sound and Engineering and Tonmastering, ISSET 2003, 11-13 September 2003, Wrocław, Poland.
- [11] ODYA P., *Method of Evaluating the Digital Speech Aid Efficacy (in Polish)*, Lth Open Seminar on Acoustics, 23-27 September 2003, Szczyrk-Gliwice, 366-369.
- [12] RIPER VAN CH., *The nature of stuttering*, New Jersey, Englewood Cliffs, 1982.
- [13] STARKWEATHER C.W., *A simple theory of stuttering*, Journal of Fluency Disorders, Vol. 20, No. 2, June 1995, 91-116.

SUMMARY (KOREKTOR MOWY NOWEJ GENERACJI)

Współczesne Cyfrowe Procesory Sygnałowe (ang. DSP) mają niewielkie wymiary, ale są w stanie realizować złożone algorytmy. Ich dodatkową zaletą jest łatwość wymiany oprogramowania, a co za tym idzie łatwość zmiany dziedziny zastosowań. Wykorzystując możliwości procesorów stało się możliwe budowanie miniaturowych protez słuchu i mowy. W referacie skupiono się na zagadnieniach związanych z projektowaniem i implementacją algorytmów mających zastosowanie w korektorach mowy. Przykładowo, opóźnienie sygnału mowy bądź jego kompresja widmowa często powoduje wzrost płynności mowy u osób jękających się. W referacie zawarto także opisy dodatkowych algorytmów zwiększających jakość przetwarzanych sygnałów dźwiękowych oraz informacje na temat stworzonego subminiaturowego korektora mowy. Testy kliniczne wskazują, że opracowane urządzenie poprawia płynność mowy osób jękających się. Opis testów ich wyniki przedstawiono w referacie.