

NUMERICAL SIMULATION OF A THIN-WALLED BEAM WITH WARPING STIFFENERS UNDERGOING TORSION

IRENEUSZ KREJA AND CZESŁAW SZYMCZAK

*Civil Engineering Faculty, Gdansk University of Technology,
Narutowicza 11/12, 80-952 Gdansk, Poland
{ikreja,szymcze}@pg.gda.pl*

(Received 9 May 2002)

Abstract: A new approach to numerical simulation of behavior of thin-walled beams of open cross-section with some warping stiffeners is presented. The structure model consists of one-dimensional finite elements described by the standard theory of thin-walled beams with non-deformable cross-section and FEM superelements with warping stiffeners. Comparative study of different kinds of modeling of the beams is performed; some numerical examples of simulation of I-beams behavior are given.

Keywords: thin-walled beams, warping stiffeners, torsion

1. Introduction

Thin-walled beams with open cross-section, frequently used in engineering structures, have relatively small torsional stiffness. The performance of the structure can be considerably improved by adding some constructional stiffeners like lateral diaphragm, batten or cross lattice (Figure 1). Any stiffener of that kind partially prevents the cross-section warping; therefore it is often called the “warping stiffener”.

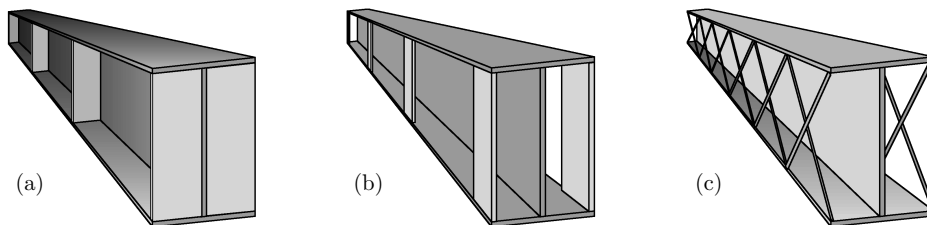

Figure 1. Warping stiffeners in I-beam: (a) lateral diaphragms, (b) battens, (c) cross lattices

A proper analysis of thin-walled beams with warping stiffeners requires appropriate mathematical modeling. Thin-walled beams with open cross-section can be very efficiently analyzed numerically with the use of one-dimensional beam model [1]

based on the classical theory of thin-walled bars with non-deformable cross-section [2]. Lateral diaphragms and battens can be rather easily included in that model just by adding simple spring elements restraining the cross-section warping (Figure 2). A discrete stiffness, which has to be built-in at nodal points localised at the place of warping stiffeners, can be estimated from the suitable formulas available in literature [3, 4]. An alternative approach is to replace the stiffeners with substitute sidewalls of adequately calculated thickness. As a consequence the obtained model has to be considered locally as thin-walled beam with closed cross-section [5].

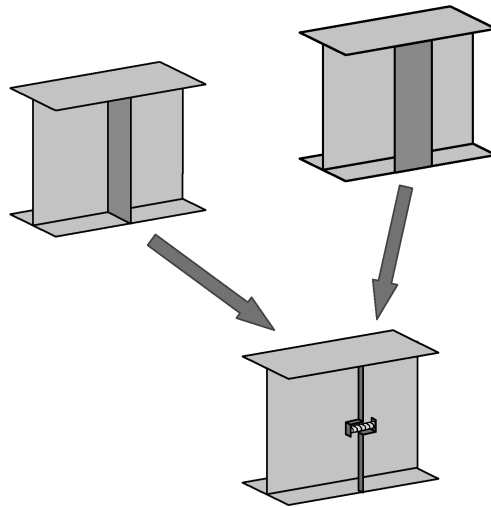

Figure 2. An idea of discrete bimoment constraints

In a real construction one can observe that the deformation of thin-walled beam in the surrounding of any brace (either diaphragm or batten) does not satisfy the assumptions of classical theory of thin-walled bars. An identification of stiffness of battens based on the free vibration FEM analysis performed in [6] for thin-walled beam with warping stiffeners resulted in much smaller values of stiffness than those evaluated according to formulas given in [3, 4].

Looking for a more exact model of warping stiffeners used in thin-walled beams, the authors of the present study introduced the concept of a beam superelement. The main idea is to represent a thin-walled beam segment with warping stiffeners as an assemblage of shell type finite elements. The obtained FEM model is then employed to construct a stiffness matrix of one-dimensional beam-like element with respect to the set of degrees of freedom matching those of the “standard” thin-walled beam element without any stiffener [1]. The described above procedure can be performed with any FEM system containing suitable shell elements. In the present paper the NASTRAN [7] system with QUAD4 shell elements is utilised for this purpose.

Two kinds of modelling of a thin-walled structure with warping stiffeners have been incorporated in a comparative study for some beam examples. One-dimensional elements were employed in the discretization of the analysed beams, whereas the stiffeners were modelled either as discrete springs [2, 3] or in the form of the proposed herein superelements.

2. Construction of stiffness matrix for superelement

To obtain a stiffness matrix of a superelement the examined thin-walled beam segment together with lateral diaphragms or battens is modelled with QUAD4 shell elements in MSC NASTRAN FEM system. The whole model is subjected to a set of unit displacements matching the 14 degrees of freedom of the thin-walled beam element (Figure 3). The resultant 14 reaction forces for each enforced unit displacement form the corresponding column of the stiffness matrix.

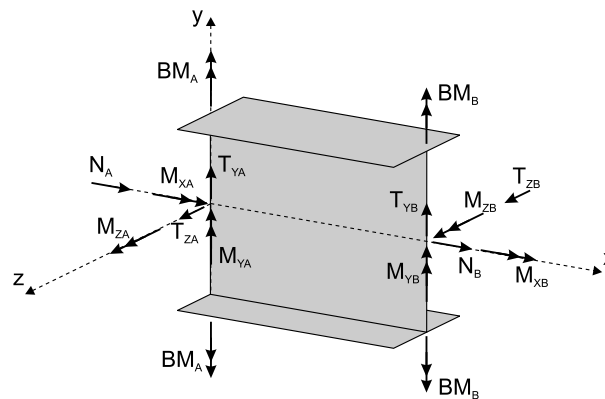

Figure 3. Thin-walled beam element with 14 degrees of freedom

It is well known that the bending behavior of bisymmetric thin-walled beams is decoupled from their torsional performance. Since the scope of this paper is limited to the torsional problems of I-beams, the size of matrices considered hereafter could be limited to 4×4 .

A typical thin-walled beam segment, 40cm long, shown in a figure in Table 1, has been adopted for further considerations. From a standard convergence FEM analysis it has been found that mesh of $2.5\text{cm} \times 2.5\text{cm}$ QUAD4 shell elements provides good accuracy of results. The adequate discretization has been applied to construct stiffness matrices for three types of a thin-walled beam segment: without any stiffeners, with batten plates and with diaphragms as presented in Figure 4 that illustrates the case of a unit enforced rotation at end B.

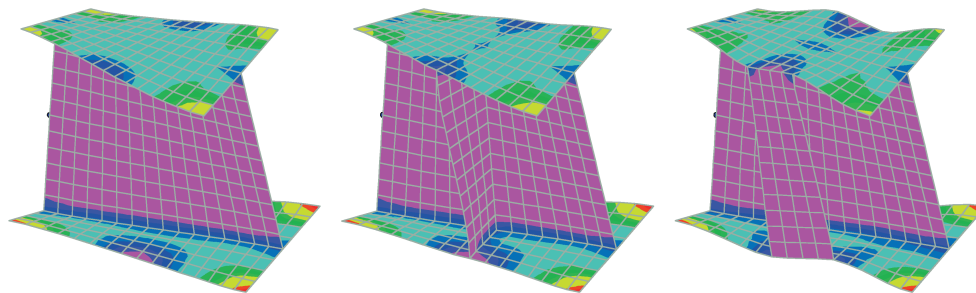
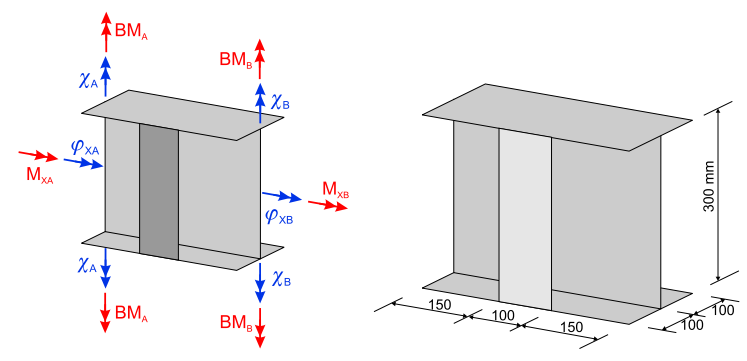
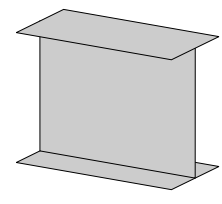
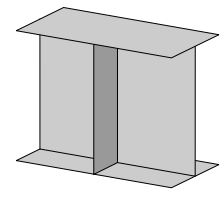
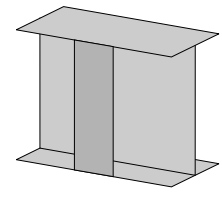

Figure 4. Thin-walled beam segments modelled with QUAD4 shell elements – von Misses stress distribution due to the unit rotation at end B

The stiffness matrices obtained in the way described above are presented in Table 1.

Table 1. Stiffness matrices of typical thin-walled beam segments



	φ_{XA}	χ_A	φ_{XB}	χ_B	
	6571977	-1301955	-6571977	-1301955	M_{XA}
		412677	1301955	108150	BM_A
			6571977	1301955	M_{XB}
				412677	BM_B
	6595030	-1302836	-6595030	-1302836	M_{XA}
		413830	1302836	107891	BM_A
			6595030	1302836	M_{XB}
				413830	BM_B
	6696861	-1301805	-6696861	-1301805	M_{XA}
		422489	1302836	98614	BM_A
			6696861	1301805	M_{XB}
				422489	BM_B

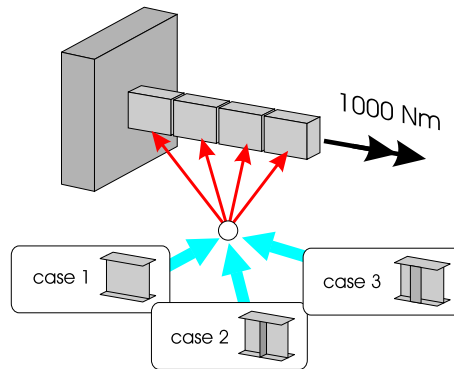

Figure 5. Four segment cantilever beam under torsion

3. Numerical examples

3.1. Cantilever beam

To analyze the influence of warping stiffeners on the torsional performance of thin-walled beam a cantilever beam under a torque at the free end has been considered in three different forms:

- Case 1 – I-beam without any stiffeners,
- Case 2 – I-beam with lateral diaphragms,
- Case 3 – I-beam with battens.

It was assumed that analyzed cantilever beam consisted of four equal segments as shown in Figure 5. Stiffness matrices presented in Table 1 have been used in calculations carried out by a computer program for matrix operations, PRISM [8]. The angle of twist graphs obtained for all three cases are presented in Figure 6. One can notice that by adding lateral diaphragms, the torsional stiffness of the beam increases by 12%. However, using the same amount of material for battens instead of lateral diaphragms is much more effective since 64% increase of the beam torsional stiffness has been obtained for Case 3.

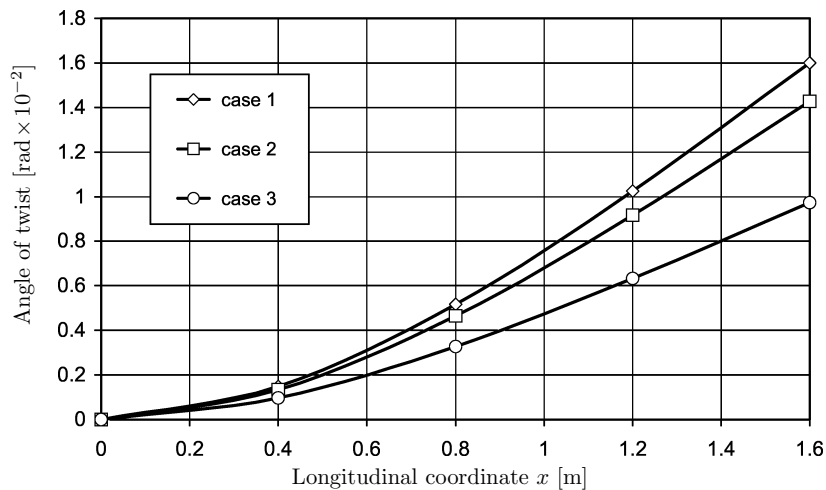

Figure 6. Graphs of twist angle for cantilever beam

3.2. Simply supported beam

In the second example the two cases of warping stiffeners have been considered for a simply supported I-beam under mid-span torque as presented in Figure 7.

Three kinds of modelling of the analysed thin-walled structure with warping stiffeners have been used in the comparative study:

1. analytical model: thin-walled one-dimensional beam elements [1] with stiffeners modelled as discrete springs [2, 3],
2. superelement approach proposed in the present paper: one-dimensional beam elements [1] with segments containing warping stiffeners modelled as FEM superelements (see Figure 8),

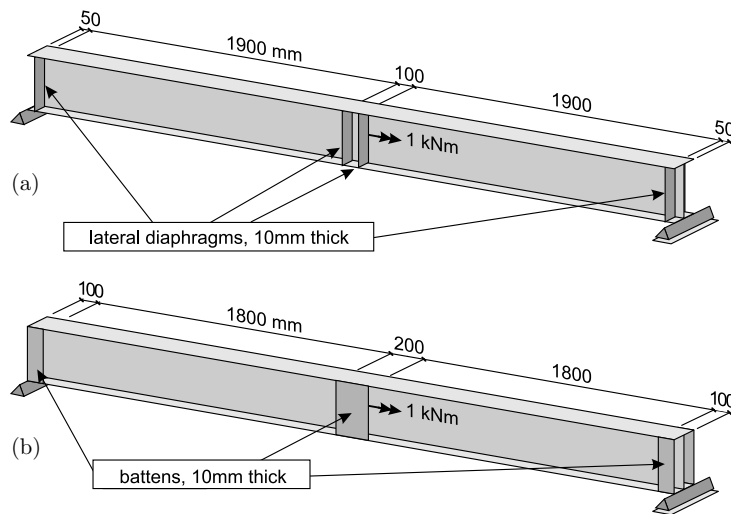

Figure 7. Simply supported I-beam with warping stiffeners: (a) thin-walled structure with lateral diaphragms, (b) thin-walled structure with battens

3. large FEM model where half of the beam has been analysed with almost ten thousand QUAD4 shell elements.

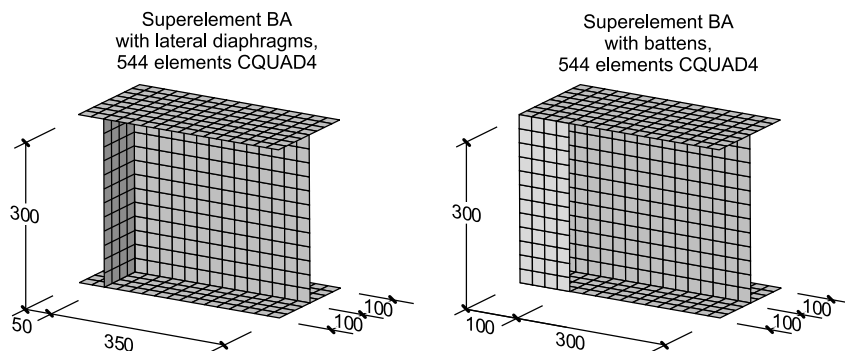

Figure 8. FEM superelements used for I-beam segments with warping stiffeners

The graph of twist angle obtained for the beam with lateral diaphragms is presented in Figure 9.

One can notice that spring model of diaphragms gives a good prediction of twist angle, which is very close to the results of large FEM model (102.4% for the twist angle at the mid-span section). The FEM superelement model, on other hand, seems to be too stiff (91.5% of the large FEM model result for mid-span twist angle).

The twist angle calculated for the beam with battens is presented in Figure 10.

The spring model of battens gives rather poor prediction of twist angle (68% of the large FEM model result for the twist angle at the mid-span section). It is worth to point out here that the second available in literature model of the batten spring stiffness, the one neglecting the shear effect, would produce an even stiffer solution (62.6% of the large FEM model result). The FEM superelement model of beam with battens gives 93.7% of large FEM model solution.

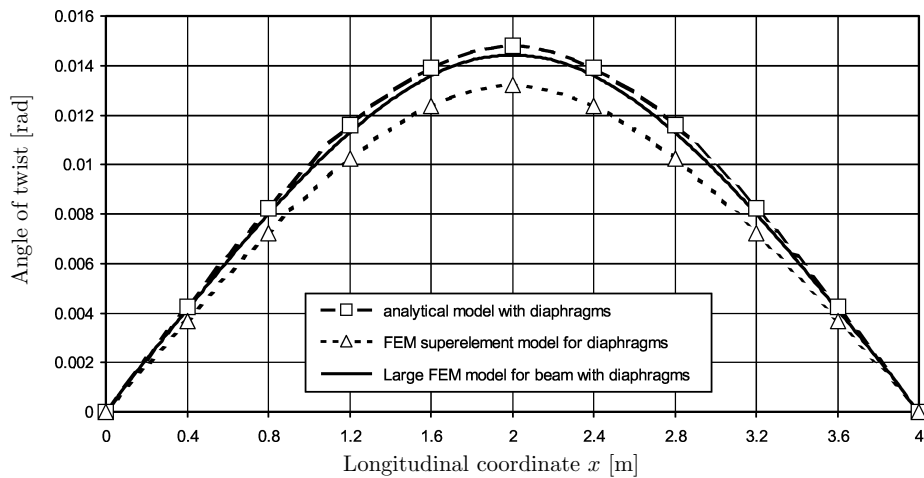

Figure 9. Twist angle for simply supported beam lateral diaphragms

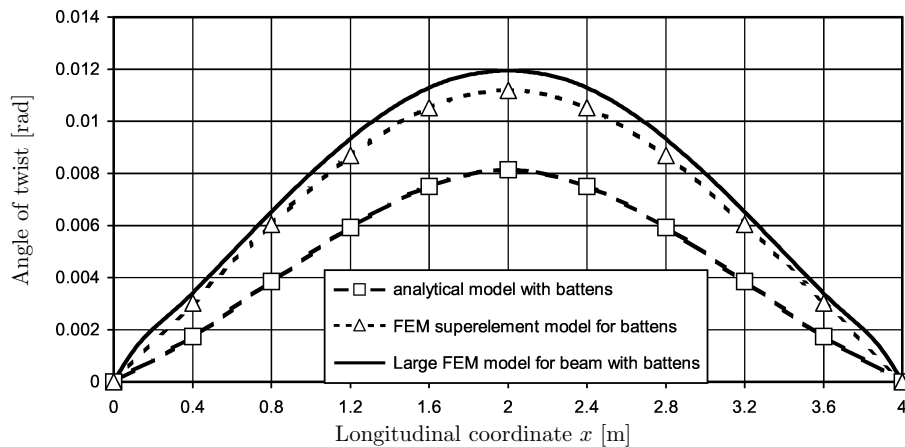

Figure 10. Twist angle for simply supported beam battens

4. Conclusions

Numerical simulations performed for thin-walled beams with constructional stiffeners pointed out the essential influence of the analyzed stiffeners on the torsional behavior of the structure. Using battens proved to be more effective for torsional stiffness of the thin-walled beam than application of lateral diaphragms. The right computational model for thin-walled beams with warping stiffeners is required to obtain proper results. As an alternative to detailed FEM discretization of the whole structure, a concept of FEM superelements for thin-walled beam segments with constructional stiffeners is proposed in the paper. This new approach seems to be especially attractive for analysis of thin-walled beam with battens where analytical formulas given in literature [2, 3] do not give correct values of stiffness parameters.

Acknowledgements

The financial support of the State Committee for Scientific Research (KBN, Poland) under Grant No. 7 T07E 01519 is gratefully acknowledged.

**References**

- [1] Barsoum R and Gallagher R H 1970 *Int. J. Numer. Methods Engng.* **2** 335
- [2] Vlasov V Z 1961 *Thin-Walled Elastic Beams. Israel Program for Scientific Translations*, Jerusalem, Oldbourne Press, London
- [3] Svensson S E and Plum C M 1983 *J. Struct. Engng. ASCE* **109** 758
- [4] Szewczak R M, Smith E A and DeWolf J T 1983 *J. Struct. Engng. ASCE* **109** 1635
- [5] Dąbrowski R 1958 *Engng. Trans.* **101** 283 (in Polish)
- [6] Szymczak C and Mikulski T 2001 *Proc. Gdansk University of Technology* **585** 273 (in Polish)
- [7] MacNeal-Schwendler Corporation 1995 *MSC/NASTRAN for Windows Installation and Application Manual*
- [8] Branicki C J and Wekezer J W 1990 *Appl. Engng. Education* **6** (4) 451

