

PROCEEDINGS OF SPIE

SPIDigitalLibrary.org/conference-proceedings-of-spie

Phase-difference positioning in asynchronous system

Jaroslav Sadowski

Copyright 2018 Society of Photo-Optical Instrumentation Engineers (SPIE). One print or electronic copy may be made for personal use only. Systematic reproduction and distribution, duplication of any material in this publication for a fee or for commercial purposes, and modification of the contents of the publication are prohibited.

Jaroslav Sadowski, "Phase-difference positioning in asynchronous system," Proc. SPIE 10715, 2017 Radioelectronic Systems Conference, 1071503 (19 April 2018); doi: 10.1117/12.2317552

SPIE.

Event: Radioelectronics Systems Conference, 2017, Jachranka, Poland

Under License: CC BY-NC-ND 4.0

Phase-difference positioning in asynchronous system

Jaroslav Sadowski

Department of Radio Communication Systems and Networks
Faculty of Electronics, Telecommunications and Informatics
Gdansk University of Technology, Gdansk, Poland

ABSTRACT

This paper presents concept and implementation of digital positioning system based on phase difference measurements, designed as a navigational aid for marine applications. Main feature of proposed system is the ability to work in both synchronous mode, with one master station and set of slave stations synchronized with master, and in asynchronous mode with independent clocking of all stations.

Keywords: radiolocalization, radionavigation, asynchronous systems, phase-difference measurement

INTRODUCTION

Precise and reliable estimation of watercraft position is crucial not only for effectiveness of maritime operations, but first of all for safety. For more than a hundred years the maritime navigation and positioning is aided by various radio-based methods, from an omnidirectional beacons and a radio direction finders to a global navigation satellite systems (GNSS). The satellite systems, such as GPS, GLONASS or European system Galileo which is still in development phase, are nowadays the most frequently used sources of maritime positioning and navigational data. But as these systems are controlled by governments of other countries, relying only on satellite navigation may lead to some security threats, such as limited or restricted availability of navigational service, degradation of position estimation accuracy or even intentional errors in navigational data. Taking it into account, development of independent, ground-based radiolocalization and radionavigation systems as a backup solution for domestic use should be considered as important part of national security. Nowadays Polish section of the Baltic Sea is not covered by any fixed, ground-based positioning system. Swedish chains of Decca^{[1][2]} have been switched off at the end of XX century^[3], while Syledis network in Poland was in fact never widely used and now is dismantled^[4]. Taking into account limitations of existing systems, experience gained during tests of a radiolocation system with spread spectrum signals^[5] and requirements for a medium-range mobile radionavigation system, defined by the Polish Ministry of National Defence, author decided to build a digital positioning system for marine applications. Unique feature of proposed system is the ability to work in two modes:

- synchronous mode: classic solution with designated master transmitter and chain of synchronized slave transmitters,
- asynchronous mode: where all the base stations are clocked by free-running oscillators, without synchronization.

The asynchronous emission allows to improve system reliability due to elimination of a single point of failure, which is usually the master station in the synchronous systems.

PRINCIPLE OF OPERATION

Digital positioning system working in medium frequency (MF) band was designed to combine the advantages of measurements of the phase differences between signals received from a set of transmitters in fixed positions (high resolution of measurements, wide range of operation) with high reliability of asynchronous solutions. Unfortunately, positioning systems based on phase measurements have one major drawback, caused by ambiguity of distance estimation due to periodicity of phase measurements as a function of position. The same value of phase differences, recorded by the mobile receiver, may refer to wide range of propagation path length (distance) differences from the base stations to the receiver. In classic carrier phase based systems this disadvantage results in need to estimate the initial position of the



receiver using other sources (e.g. satellite navigation or manual data entry), and after that the receiver must count occurrences of zero phase difference measurements which designates next hyperbolas of possible position. It means that the required accuracy of the initial position data in classic solution is comparable to half of a radio wavelength, so for medium-wave system it must not be worse than several tens of meters. Transmission of positioning signals on two different frequencies allows to decrease required accuracy of initial position estimation due to elimination, from the set of possible receiver positions, these hyperbolas defined by measured differences in phases of received signals, which are not convergent on both frequencies of measurements. But even in two-frequency phase-difference measurement positioning system, the problem of dependence on external sources of initial data remains.

In proposed solution the base stations (BS) are transmitting positioning signals on almost any two frequencies in range 1.6 MHz to 2 MHz. These signals are BPSK-modulated and all the base stations in one network are working on the same pair of channels using TDMA technique with frequency switching. One emission on one frequency lasts 120 ms (total time, including transmitter switch on/switch off, synchronization preamble, useful data and forward error correction) and is transmitted in 125 ms long time slot. In a network consisting N_{BS} base stations (minimal number of transmitters: $N_{BS}=3$, but in order to improve system reliability by redundancy, real systems should be built with at least 4 stations) emission of signal by a given transmitter on a given frequency is repeated every $2 \cdot N_{BS} \cdot 125$ ms. Figure 1 presents example of emission arrangement on two frequencies in the network created by four base stations.

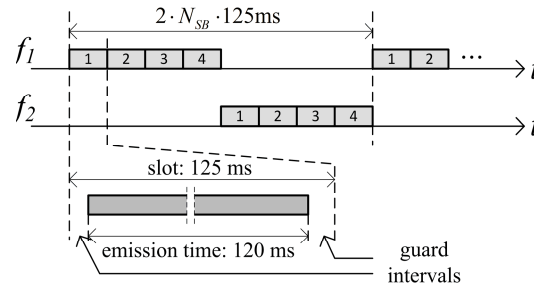

Fig. 1. Structure of positioning signals emission in time and frequency domain.

In classic, synchronous phase-difference measurement systems, all the reference transmitters must send their signals in certain moments in time, taking special care to maintain correct initial phase of transmitted carrier. For simplicity, let's consider phase differences measurements of signals from one pair of base stations. The phases of carriers emitted by the first transmitter (φ_{r1}) and the second one (φ_{r2}) must be constant to avoid crawling of hyperbolic grid, and must be known by the receiver, so it may be assumed that both values are zero:

$$\varphi_{r1}(t) = 0 \quad (1)$$

$$\varphi_{r2}(t) = 0 \quad (2)$$

The positioning receiver, which is located at distance d_1 from the first transmitter and d_2 from the second transmitter, receives signals with phases:

$$\varphi_{r1}(t) = \varphi_{r1}(t) - (d_1/\lambda) \bmod \lambda \quad (3)$$

$$\varphi_{r2}(t) = \varphi_{r2}(t) - (d_2/\lambda) \bmod \lambda \quad (4)$$

where λ is wavelength. When the receiver is stationary, the phases (3) and (4) are constant, equal φ_{r1} and φ_{r2} respectively. Due to fact that in typical TDOA systems, the receivers are not synchronized with the network of transmitters, they cannot directly measure phases of received signals, but only phase difference:

$$\Delta\varphi_{r21}(t) = \varphi_{r2}(t) - \varphi_{r1}(t) = (\varphi_{r2}(t) - \varphi_{r1}(t)) - \left(\frac{d_2 - d_1}{\lambda} \right) \bmod \lambda \quad (5)$$

Estimation of the distance difference $d_2 - d_1$ from (5) requires identification of correct position lane using the initial receiver coordinates and the zero phase crossing counters.

In general, in the asynchronous system the initial phases of signals transmitted by the reference stations, clocked from the free-running reference frequency sources, are variable. However, when the short-term stability of the reference clocks is high enough, the initial phases of consecutive emissions from each transmitter may be modelled by a linear

equation with coefficients calculated from an instantaneous phases of several tens of last emissions using least squares algorithm. So instead of real values of phases of transmitted signals: $\varphi_{i1}(t)$ and $\varphi_{i2}(t)$ approximate values may be used:

$$\hat{\varphi}_{i1}(t) = a_1 t + b_1 \quad (6)$$

$$\hat{\varphi}_{i2}(t) = a_2 t + b_2 \quad (7)$$

The parameters of the linear approximation a_1, b_1 and a_2, b_2 are in fact time-variables so they are updated frequently, and they must be known by the receivers so they are broadcasted by all the base stations using a data channel. The laboratory tests proved that such linear approximation of initial phases of emitted positioning signals is sufficient when the transmitters are clocked by an oscillators with short term frequency stability 10^{-9} or better, allowing to get a phase prediction error lower than 1° during time up to several tens of seconds since last update of the equation coefficients.

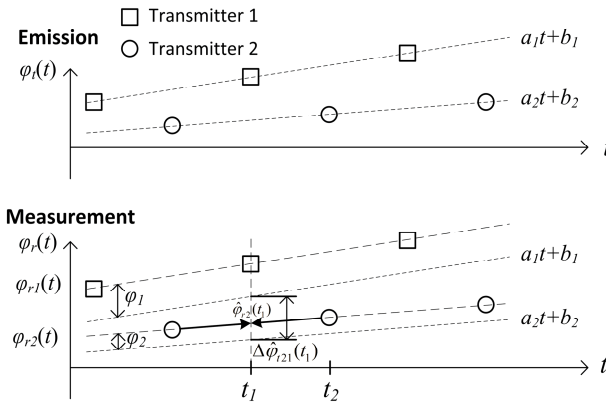

Fig. 2. Carrier phase difference measurements in asynchronous mode.

Calculation of the phase difference which corresponds to the real distance difference in positioning receiver is made in few steps. Even in case of stationary reception, the phases of received signals are time-variables due to variable phases of transmission. When the linear model coefficients a_1 and a_2 are not equal, simple subtraction of the measured and estimated phases in timestamp t_1 and t_2 :

$$\Delta\varphi_{r,21}(t_1, t_2) \approx (\varphi_{r,2}(t_2) - \hat{\varphi}_{i2}(t_2)) - (\varphi_{r,1}(t_1) - \hat{\varphi}_{i1}(t_1)) \quad (8)$$

is not correct due to a systematic error:

$$\varepsilon = |(a_2 - a_1) \cdot (t_2 - t_1)| \quad (9)$$

caused by estimation of the phase values $\hat{\varphi}_{i1}(t_1)$ and $\hat{\varphi}_{i2}(t_2)$ in two different time moments. In addition: in case of mobile receiver, phase shift caused by change of a speed or a direction of movement may not be linear function of time, therefore simple compensation of phase difference estimation error expressed by (9) turned out not to be satisfactory. Instead, better results were obtained when all the calculations were made using one timestamp, t_1 in example presented in fig. 2. The measurement of the phase from the first transmitter, performed in time t_1 , needs no further corrections, but the phase of signal from the transmitter 2 must be interpolated to $\hat{\varphi}_{r,2}(t_1)$ from set of previous measurements and the newest measurement $\varphi_{r,2}(t_2)$ in time t_2 , using polynomial interpolation. Finally, the estimated value of phase difference, corresponding only to the difference in distances to both transmitters, may be calculated from:

$$\Delta\hat{\varphi}_{r,21}(t_1) = (\hat{\varphi}_{r,2}(t_1) - \varphi_{r,1}(t_1)) - \Delta\hat{\varphi}_{i,21}(t_1) \quad (10)$$

where:

$$\Delta\hat{\varphi}_{i,21}(t_1) = (a_2 t_1 + b_2) - (a_1 t_1 + b_1) = (a_2 - a_1) t_1 + (b_2 - b_1) \quad (11)$$

is an estimated difference in the phases of emitted signals in time t_1 . Therefore, the mobile positioning receiver is able to find the approximated value of the phase difference from not synchronized, but stable clocked transmitters. It must be noted, that in the real asynchronous system none of the base stations is able to calculate absolute values of parameters of the linear phase models a_1, b_1 and a_2, b_2 , because of an unknown time shift between a local time in transmitters and a global time. Instead, all the models are prepared as differential ones, with coefficients $a_{21} = a_2 - a_1$ and $b_{21} = b_2 - b_1$.

Automatic operation of proposed system in asynchronous mode requires two-way communication between all the base stations and one way data transmission from the base stations to all the mobile receivers. The data transmission channel is made by BPSK modulation of the positioning signals. Every transmitter sends one data packet in each assigned time slot. The data exchange is based on a broadcast messages. Firstly, all the base stations must inform all the other base stations and all the mobile receivers about their coordinates. Next, the base stations are measuring differences in their clocks and preparing linear models of phase prediction. The coefficients of linear equations are then broadcasted to all the receivers. Although the position estimation is the last step, presented on Fig. 3, all the base stations are repeating the broadcast messages with their coordinates and prediction models, updated after every successful reception of signals from other stations.

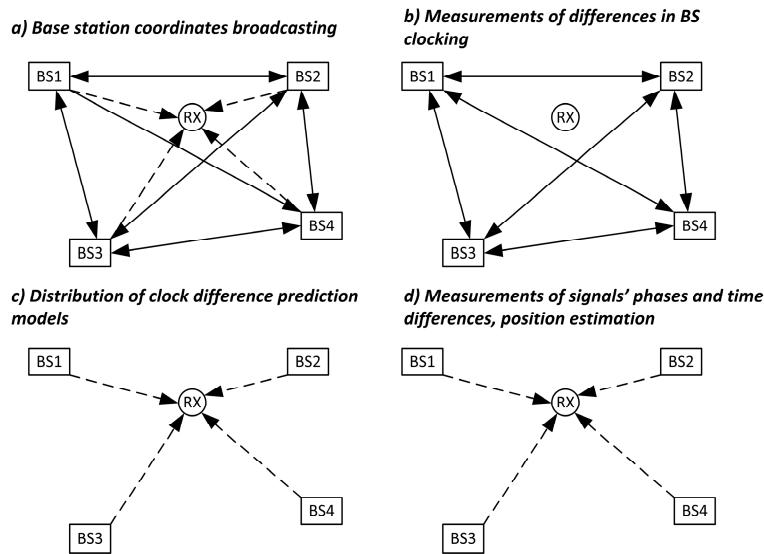

Fig. 3. Data exchange in positioning system in asynchronous mode.

In the classic, synchronous systems, the time of emission of all signals from set of synchronized transmitters will be automatically maintained during whole time of operation. In contrary, in the asynchronous version, independent clocking of all the base stations will cause slow, but systematic drift of not only initial phases of the transmitted signals, but also position of the transmitted packets in the TDMA time slots. In order to ensure possibility of interference-free reception of all signals by the mobile receivers, guard intervals of total 5 ms are provided in all the TDMA time slots. Due to fact that it is difficult to define an exact limits of the consecutive slots in the asynchronous network, it is assumed that slots are defined by averaging time of emission of the signals from all the transmitters. As long as the time of emission of certain transmitter does not differ from averaged time by more than 0.5 ms (duration of one BPSK symbol), the transmission is scheduled by a local clock. But when the difference exceeds defined limit, the transmission time of that station is corrected by ± 0.5 ms. Sudden shift of the emission time is easily detected by all receivers and corrected immediately.

In order to get fully automatic system operation, the problem of unknown initial position of the receivers had to be solved. It was achieved by an additional measurements of differences in time of arrival of all radio packets, based on a correlation of samples of the received radio signals with a locally generated templates of the modulated BPSK signal, consisting the same stream of bits (baseband signal regenerated from decoded data packets). The time of signal reception is estimated with subsample resolution using bank of fractional delay filters. But even in case of high signal to noise ratio, the estimation of the time of reception by correlation is performed with the accuracy two orders of magnitude worse than accuracy of phase difference measurements. So in order to combine data from both methods of measurements, the receiver generates a histogram of time of reception for several tens of data packets, which is then approximated by a Gaussian function. The maximum of this function indicates the most probably value of the distance differences expressed by measured difference of received phases and variable integer multiplicity of half wavelength, after subtraction of predicted difference in emission of signals from base stations using linear prediction models.

PROTOTYPE OF ASYNCHRONOUS POSITIONING SYSTEM

The prototype of the asynchronous positioning system with carrier phase measurements was built in mixed form. The transmitters are based on a dedicated hardware, while the receivers were made using a commercial, general purpose receivers EM550 from Rohde&Schwarz. The EM550 receivers were equipped with an additional frequency converters, synchronized with internal receiver oscillators, which allowed to extend their range of reception to cover band 1.6 MHz to 2 MHz. The prototype consists of four base stations, all of them having transmitting and receiving part, and one mobile positioning receiver, with the same structure as receiving part of base stations. Block diagram of the base station is presented on Fig. 4. All the prototypes may work in both synchronous (master-slave) and asynchronous modes.

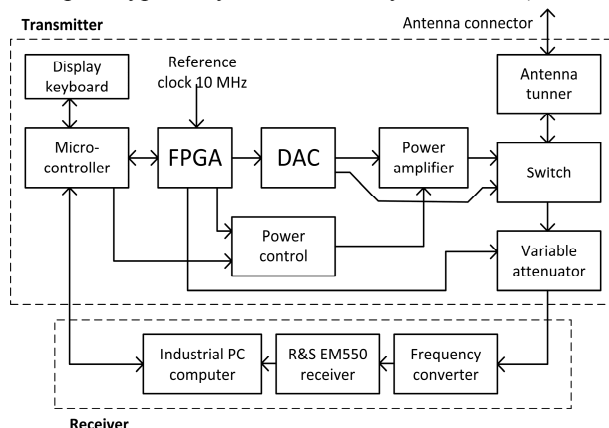

Fig. 4. Block diagram of base station hardware.

The positioning signals are generated directly in digital form inside FPGA array. Signal generation chain in FPGA consists of two carrier generators, based on a digital direct synthesis (DDS), a packet generator, a CRC encoder, a convolutional encoder and a digital BPSK modulator with a pre-modulation filters. Stream of samples at the input of a digital to analogue converter (DAC) represents signal on desired transmission frequency, not in the baseband, so the output signal from DAC is directly amplified and transmitted without need for additional analogue modulation or frequency conversion. This allowed to achieve high repeatability of parameters of all transmitters, required by correlator-based estimation of time of signals' reception in receivers.

The mobile positioning receiver and all the receivers in the base stations were made using a software defined radio (SDR) concept. Stream of I/Q samples from the EM550 receiver is transmitted via an Ethernet interface to an industrial PC computer. Dedicated software, written in C, is responsible for demodulation, detection of packets, data interpretation, as well as measurements of differences in phases of received carriers and measurements of differences in time of reception of data packets via correlation. In addition, the SDR receiver software in the base stations calculates the parameters of the models used for the prediction of differences in base station clocking. The software of the mobile receiver is also responsible for final estimation of differences in distances from the base stations, calculation of current coordinates and position presentation in a selected coordinate system.

LABORATORY TESTS

Laboratory tests were performed using prototypes of four base stations and one mobile receiver. All devices were connected only using antenna connectors via variable attenuators, allowing to change level of received signals in range between -114 dBm (limited by packet error rate equal 10^{-1}) and -50 dBm. The transmitters were working on frequencies $f_1=1.8$ MHz and $f_2=1.85$ MHz with independent sources of reference clocks: rubidium oscillators, crystal oscillators with temperature stabilization (ovenized) and crystal oscillators without stabilization. All the tests were performed in stable state, after preparation of the prediction models in the asynchronous mode, which takes up to 95 seconds, or after slave synchronization in the synchronous mode (approx. 60 seconds). The mobile receiver can return first position estimate 5 seconds after a cold start, and update results after successful reception of any new radio packet (up to 8 times per second).

Due to fact, that emulation of variable delay of radio signals in laboratory is not an easy task, author decided to test the prototype of the positioning system with equal propagation delay between all the transmitters and the mobile

receiver. Assuming that all four transmitters broadcast their coordinates corresponding to corners of a square, mobile receiver should return its position in the centre of square, which simplifies evaluation of system errors. The value MED in table 1 is a mean value while RMSEd is a root mean squared value of a distance difference estimation error. Values MExy and RMSExy are mean and root mean squared values of a final position estimation error respectively. All the results presented in table 1 were calculated from a series of 1000 consecutive measurements.

Table 1. Distance difference measurement errors and position estimation errors measured in laboratory.

Reference frequency source	MED [m]	RMSEd [m]	MExy [m]	RMSExy [m]
Synchronous mode				
Rubidium frequency standard (10^{-11})	-0.141	0.199	0.153	0.160
Ovenized crystal oscillator (10^{-9})	-0.098	0.168	0.118	0.129
Crystal oscillator without temperature control (10^{-7})	-0.126	0.283	0.175	0.203
Asynchronous mode				
Rubidium frequency standard	-0.052	0.106	0.071	0.080
Ovenized crystal oscillator	-0.073	0.110	0.080	0.085
Crystal oscillator without temperature control	0.026	1.051	0.764	0.858

In most cases, except the asynchronous mode with the transmitters clocked from the low quality crystal oscillators without temperature control (short term stability limited to 10^{-7}), the RMSE error values are limited to much less than half meter, reaching few centimetres when the transmitters are clocked from stable frequency sources (short term stability 10^{-9} or better). Performance of the positioning system in both synchronous and asynchronous modes is comparable, with little predominance of asynchronous one. It is mainly caused by a limited step of phase correction in the DDS frequency synthesizers in FPGA. Due to fact, that most sources of the reference frequency 10MHz doesn't allow for fine tuning, the synchronization of emission in the slave transmitters in the synchronous mode is performed in DDS with step of the phase correction equal 0.36° which limits possible accuracy of synchronization. In contrary, in the asynchronous mode, all the receivers performs phase measurements with resolution better than 0.1° , therefore allowing for higher precision of modelling differences in clocking in the asynchronous mode.

CONCLUSIONS

The presented prototype of the asynchronous positioning system with carrier phase difference measurements has all the advantages such as high resolution and accuracy of position estimation, without disadvantages caused by unknown initial estimate of position in other systems of such kind. In addition, ability to work in the asynchronous mode, without selection of the master station and need of the synchronization of all the slave transmitters, may significantly improve system reliability. Fully automatic estimation and compensation of all the possible phase/time delays caused by various components of the base stations reduces a list of tasks which needs to be performed by a transmitter operators, while the mobile receivers don't require any supervision at all.

It should be noted that all the tests and results of error analysis were performed only in the laboratory. Therefore, the presented values of the position estimation accuracy don't include negative effects, which may be introduced by a radio propagation phenomena in the real environment. Therefore, some further tests are needed to evaluate full parameters of the proposed system in real scenarios in a maritime environment.

REFERENCES

- [1] Sonnenberg G.J., Radar and Electronic Navigation, Cambridge: Butterworths & Co Ltd, 6th edition (1988)
- [2] Kayton M., Fried W.R., Avionics navigation systems, Wiley, 2nd edition (1997)
- [3] Blanchard W., The Genesis of the Decca Navigator System, The Journal of Navigation, Vol. 68, 219-237 (2015)
- [4] Specht C., Weintrit A., Specht M., A History of Maritime Radio-Navigation Positioning Systems used in Poland, Journal of Navigation, Vol. 69, 468-480 (2016)
- [5] Ambroziak S., Katulski R., Sadowski J., Siwicki W., Stefański J., Ground-based, Hyperbolic Radiolocation System with Spread Spectrum Signal – AEGIR, Navigational Systems and Simulators, Marine Navigation and Safety of Sea Transportation, CRC Press/Balkema, London (2011)