

POWER EFFICIENCY OF POWER PLANTS ON TRAILING SUCTION HOPPER DREDGERS

Damian Bocheński

Gdansk University of Technology
Ul. Narutowicza 11/12, 80-233 Gdansk, Poland
Tel.: +48 58 3472773, fax: +48 58 3472430
e-mail: daboch@pg.gda.pl

Abstract

This paper presents the notion of operational power efficiency and compares it with the classical definition of power efficiency. There are presented also calculation results of power efficiency for a selected suction hopper dredger and also influence of power system type of suction hopper dredger on magnitude of power efficiency of its power plant has been highlighted.

Key words: trailing suction hopper dredger, power efficiency

1. Introduction

The decision-making on selection the most favourable variant of power system for a dredger under design is a very crucial designing phase which makes it possible to choose basic elements of the power system.

Such selection is preceded by technical-economic analysis. To perform the analysis the following tools are used: multi-criterion assessment methods, one-criterion method as well as economic effectiveness indices [3]. The method based on a single criterion e.g. fuel consumption cost or power efficiency of power plant, is used most often. This paper present possible application of power efficiency to selection of the most favourable variant of power system for trailing suction hopper dredger.

2. Power efficiency of dredger power plant

Ship power plant efficiency is defined as the ratio of useful power flow and flow of energy contained in fuels combusted in all fuel-consuming elements of the power system. In present the role is fulfilled by the **power efficiency of power plant** (η_{PE}), in which the useful power flow is the sum of the power produced for propeller propulsion, electric power on terminals of generators and useful heat power.

The defining of power efficiency of a dredger power plant necessitates to refer to the power balance scheme for dredger power system (Fig.1).

Outside the balance boundary the scheme shows the following:

- *at the top:* flows of energy delivered in fuels combusted in the main engine, ($G_{ME} \cdot W_d^{std}$), auxiliary engine ($G_{AE} \cdot W_d^{std}$) and auxiliary fired boiler ($G_{FB} \cdot W_d^{std}$);

- *on the left*: the useful mechanical power flows delivered to drive couplings of main mechanical power consumers (N_{MC_i}); one of them is driven by an electric motor supplied from the integrated electric generating set. All the flows together form the useful mechanical power flow (N_{MP});
- *on the right*: the useful electric power flows obtained from operation of the integrated electric generating set (N_{EL}^{kor}) as well as the suspended generator driven by the main engine (N_{SG}). All the flows together form the useful electric power flow (N_{EL});
- *at the bottom*: the useful heat power flows obtained from operation of the fired boiler (N_{FB}) and the waste-heat boiler (N_{WB}). All the flows together form the total useful heat power flow (N_{HP}). The presented waste-heat flow (Q_{str}) covers all heat losses of a value which closes balance of the system.

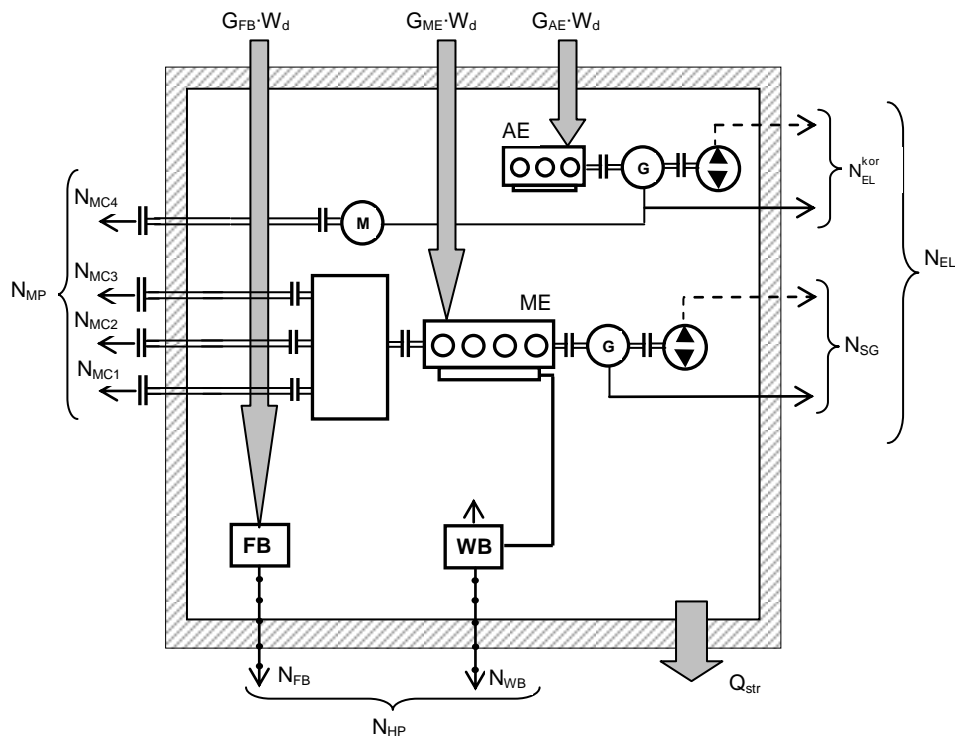

Fig. 1. Scheme of power balance of dredger power system (see the text for explanation)

The above presented data make it possible to determine value of the power efficiency of dredger power system (η_{PE}):

$$\eta_{PE} = \frac{N_{MP} + N_{EL} + N_{HP}}{(G_{ME} + G_{AE} + G_{FB}) \cdot W_d^{std}}, \quad (1)$$

An important drawback of Eq.(1) is that it deals with the instantaneous energy (power) flows shown in Fig. 1. Therefore the efficiencies are usually determined for given typical states of ship service under the assumption about constant loads on power system elements. Dredgers belong to the group of technological ships which operate in variable external service conditions and whose technological processes are characterized by high variability of loads applied to power system elements. For this reason, correct assessment of power system efficiency should deal with the entire range of varying loads in a given service state of dredger. This author has proposed [3] to introduce the notion of **the operational power**

efficiency (η_{OPE}) of dredger power plant. The efficiency takes into account total quantities of produced energy and total quantities of fuel consumed on a dredger within a given longer interval of its service. It can be expressed as follows :

$$\eta_{OPE} = \frac{E_{MP}^* + E_{EL}^* + E_{HP}^*}{(G_{ME}^* + G_{AE}^* + G_{FB}^*) \cdot W_d^{std}}, \quad (2)$$

where:

E_{MP}^* , E_{EL}^* , E_{FB}^* – total quantities of power: mechanical, electric and thermal one, respectively, produced by power system and used in a given service state and interval;

$(G_{ME}^* + G_{AE}^* + G_{FB}^*) \cdot W_d^{std}$ – total quantities of energy delivered to power system, contained in fuel combusted by main engines, auxiliary engines and fired boilers in a given service state and interval.

The total mechanical power quantity produced and used in a given service state, related to drive couplings of main power consumers is as follows:

$$E_{MP}^* = \tau_{ss} \cdot \sum_{i=1}^n N_{MC,i}^{av} \cdot \lambda_{MC,i}^{ss}, \quad (3)$$

where:

τ_{ss} - duration time of service state;

$N_{MC,i}^{av}$ - mean power of main consumer;

$\lambda_{MC,i}^{ss}$ - duration time of main power consumer operation in a given service state.

The main power consumers on suction hopper dredgers cover the following items [1,3,4]:
 — consumers associated with the propelling, positioning and manoeuvring of dredger (main-propulsion propellers, thrusters);
 — consumers associated with the loosening and transporting of soil (soil pumps , fluffing pumps).

The total electric power quantity produced and used corresponds with the demand for it from the side of all electric power consumers :

$$E_{EL}^* = \tau_{ss} \cdot N_{EL}^{av}, \quad (4)$$

where:

N_{EL}^{av} - mean demand for electric power;

The total quantity of produced and used heat power is associated with the satisfying of the demand for it from the side of heat power consumers :

$$E_{HP}^* = \tau_{ss} \cdot N_{HP}^{av}, \quad (5)$$

where:

N_{HP}^{av} - mean demand for heat power;

3. Characteristics of power plant of trailing suction hopper dredgers

Classification of solutions of dredger power plant depends on an assumed criterion of classification. In [3] the following distinguishing criterion has been proposed: a manner of driving the main consumers, expressed by number of main engines or - equivalent to them - main multi-engine systems. Solutions of power systems of suction hopper dredgers should be considered within the following types:

- **Type I** – covering systems in which is installed only one main engine or -equivalent to it - main multi-engine system providing drive for all main consumers used on the dredger;
- **Type II** – covering systems with two main engines or - equivalent to it - two main multi-engine systems;
- **Type III** – covering systems with three main engines (or three multi-engine systems); main ship propellers and dredge pumps are driven by separate engines and one common engine drives jet pumps and thrusters;
- **Type IV** – covering systems with four main engines (or four multi-engine systems). The type is characterized by a combustion engine (or engines) for driving each main consumer separately.

4. Calculation example

Beneath are presented calculations of values of the power efficiency (η_{PE}) of power plant and the operational power efficiency (η_{OPE}) of power plant for an example suction hopper dredger of medium size [2].

Principal technical parameters of the suction hopper dredger in question:

• Total length	95,00 m
• Length between perpendiculars	85,00 m
• Breadth	19,65 m
• Maximum draught	5,70 m
• Dredger speed under full load	11,5 knots
• Maximum depth of dredging	30,0 m
• Number of external suction pipes	1 pc
• Diameter of external suction pipe	800 mm
• Deadweight	6200 t
• Load carrying capacity	5500 t
• Dredge hopper capacity	4000 m ³
• Number of crew members	12÷14 persons

By making use of the preliminary design methods for power plants on dredgers [3] the parameters of main power consumers were determined as follows:

- Two ducted controllable-pitch screw propellers of the maximum propulsion power (MCR) = 2×1500 kW;
- One dredge pump of 1100 kW (loading)/2000 kW (unloading) power;
- Two jet pumps of 250 kW power each;
- Bow thruster of 500 kW power.

Next, parameters of demand for electric and heat power for auxiliary purposes, were determined. It made it possible to determine power of main and auxiliary engines for four types of power system on dredgers. The parameters are given in Tab. 1.

Light fuel combusting was assumed. For this reason the solution with one fired water boiler intended for the covering of heat power demand from the side of heating installation in

dredger accommodations, was accepted. Heat power of the boiler is equal to 300 kW. The heat power demand is hence identical irrespective of power system variant. The following structure of duration time of particular service states of the dredger was assumed : loading – 2480h, unloading and sailing –1860 h each.

For the selected engines, electric generating sets (of MAN firm [5]) as well as the assumed structure of duration time of particular service states of the suction hopper dredger, parameters which make it possible to calculate the power efficiency (η_{PE}) of power plant and the operational power efficiency (η_{OPE}) of power plant on the considered dredger, were calculated for four principal types of dredger power system. Tab. 2 and 3 contain results of the calculations.

Tab. 1. Main technical data of the selected combustion engines and electric generating sets for particular variants (types) of dredger power system

Type of power plant	Main engines	Auxiliary engines
I	2×ME of 2100 kW each	1×GS of 450 kW 1×HGS of 92 kW
II	2×ME of 2100 kW each 1×ME (2800 kW)	1×GS of 450 kW 1×HGS of 92 kW
III	2×ME of 1540 kW each 1×ME of 2190 kW 1×MGS of 1080 kW	1×GS of 540 kW 1×HGS of 92 kW
IV	2×ME of 1540 kW 1×ME of 2190 kW 1×ME of 540 kW 2×MGS of 540 kW each	1×HGS of 92 kW

ME – main engine, GS – generating set, MGS – main generating set, HGS – harbour generating set

Tab. 2. Values of the power efficiency (η_{PE}) [%] for the suction hopper dredger depending on its power system type and service state

Type of power plant	Dredger service state			
	Loading	Sailing	Unloading	In total ^{*)}
I	44,9	47,3	44,0	45,3
II	43,8	47,0	44,5	45,0
III	44,0	46,1	45,9	45,3
IV	43,5	46,1	45,3	44,8

^{*)} – Total for the “dredging” state which covers loading, sailing and unloading operations.

Tab. 3. Values of the operational power efficiency (η_{OPE}) [%] for the suction hopper dredger depending on its power system type and service state

Type of power plant	Dredger service state			
	Loading	Sailing	Unloading	In total ^{*)}
I	45,5	46,3	44,0	45,3
II	43,0	47,5	44,8	44,8
III	42,5	42,2	41,3	42,0
IV	42,9	42,2	43,2	42,8



*) – Total for the “dredging” state which covers loading, sailing and unloading operations

The calculation results presented in Tab. 2 and 3 reveal rather significant differences in values of the power efficiency (η_{PE}) and the operational power efficiency (η_{EE}) of power plant.

As far as the power efficiency of power plant (η_{PE}) for the whole state of “dredging” is concerned, the largest values deal with power plants of the type I and III. The difference between the maximum and minimum value is low and amounts to 0,5% only. In the case of the operational power efficiency (η_{OPE}) of power plant, the largest values concern power plant of the type I, and the difference between the maximum and minimum value amounts now even to 3,3%.

In case of the operational power efficiency (η_{OPE}) of power plant a “correct” dependence on power system type, can be observed. The type I which is characteristic of the highest degree of drive integration of main power consumers, has the highest efficiency value. The types III and IV which are characteristic of the lowest degree of drive integration of main power consumers, have the lowest efficiency value.

5. Summary

The presented results of the investigations confirmed that in the case of suction hopper dredgers, for the technical – economic analysis which has to allow for the correct selecting of crucial elements of power system, one should use the operational power efficiency (η_{OPE}) of power plant.

The results indicate simultaneously that the basic type of power system for suction hopper dredger should be the system characterized by the highest degree of drive integration of the main power consumers (i.e. the type I). And, the selection of the most favourable solution consists in choosing between variants which are various mutations of power system of the type I. Such systems are characterized by the largest values of the operational power efficiency (η_{OPE}) of power plant and also the lowest investment cost [3].

References

- [1] Balcerski A., Bocheński D.: *Technological and power systems on ocean-going floating units* (in Polish), Wydawnictwo Politechniki Gdańskiej, Gdańsk 1998
- [2] Bocheński D.: *Comparative analysis of trailing suction hopper dredgers' various types of power plants*. W: [Mat.] 4th International Scientific-Technical Conference EXPLO DIESEL & GAS TURBINE '05, Gdańsk-Międzyzdroje-Kopenhaga 2005
- [3] Bocheński D.: *The preliminary designing of power plants on dredgers with use of probabilistic models* (in Polish). Wydawnictwo Politechniki Gdańskiej, series : Monografie 142, Gdańsk 2013
- [4] Vlasblom J. W.: *Designing dredging equipment*. Lecture notes, TUDelft 2003-05
- [5] Project Guides 2012. DVD Video, MAN Diesel 2012

