

Technical Paper

Probabilistic analysis of settlements under a pile foundation of a road bridge pylon

Karol Winkelmann^{a,*}, Kamil Żyliński^{a,b}, Jarosław Górski^a

^a Faculty of Civil and Environmental Engineering, Gdańsk University of Technology, Narutowicza 11/12, Gdańsk 80-233, Poland

^b Industria Engineering, Azymutalna 9, Gdańsk 80-298, Poland

Received 20 April 2020; received in revised form 6 November 2020; accepted 12 November 2020

Available online 9 December 2020

Abstract

The paper addresses the reliability change of a road bridge pile foundation due to the unpredictable increase of settlements in time. The analysis is based on the Rędziński Bridge in Wrocław, Poland, its design assumptions, and monitoring results. The bridge foundation rests on a multi-layered subsoil assumed random. The Finite Element model of the subgrade is generated in ZSoil[®] software. To simplify the probabilistic approach, substitute soil strata stiffness parameters are adopted. Tracing their time decrement allows for a comprehensive definition of the entire foundation over-settlement produced by numerous factors. Preliminary sensitivity analysis of settlements to the stiffness variation properly simplifies the random model. The Serviceability Limit State helps to assess the foundation reliability index, further compared with the condition in the EN 1990:2002/A1:2005 standard. In addition, real-life settlements are also measured in the first year of bridge operation, they are used to calibrate the reliability index assessment. An innovative approach is proposed, where appropriate time-wise fluctuation functions represent the expected settlement increase and the related reliability reduction. These fluctuation functions help to plan the future remedial actions to maintain the initial bridge safety and to indicate the action frequency and scope. Future reliability levels may be extrapolated too. The real-life survey database of settlements makes it possible to validate the results of probabilistic calculations. A dedicated flowchart is devised to support further analysis of a wide structural domain. © 2020 Production and hosting by Elsevier B.V. on behalf of The Japanese Geotechnical Society. This is an open access article under the CC BY-NC-ND license (<http://creativecommons.org/licenses/by-nc-nd/4.0/>).

Keywords: Bridge pylon pile foundation; Over-settlements; Representative soil strata stiffness; Sensitivity analysis; Time-variant reliability

1. Introduction

Bridge foundations are usually supported on subsoils of complex geotechnical conditions. Even the in-situ investigations on these subsoils, performed directly at the location of each foundation, rarely provide the designer with sufficient information on soil parameters. In most cases standard mechanical and stiffness parameters are adopted in the Finite Element (FE) models, e.g. based on Eurocode 7 regulations. However, in some cases the standard-based

approach is insufficient, e.g. for multi-layered subsoils with high soil parameter uncertainty. As the Serviceability Limit State (SLS) of foundations is often verified directly, comparing the FEM-based displacements and their in-situ values, this verification may turn out inaccurate (Fenton et al., 1996). In such cases, the probabilistic approach to foundation analysis is necessary to complete the design process.

The reliability assessment of geotechnical structures is addressed in Annex D to the ISO2394:2015 and in (Phoon et al., 2016). A summary of reliability-based design (RBD) in geotechnical engineering is included in (Phoon, 2014). The latter addresses the numerical approach to soil strata randomness to point out high computational effort as a crucial challenge in RBD.

Peer review under responsibility of The Japanese Geotechnical Society.

* Corresponding author.

E-mail address: karolwin@pg.edu.pl (K. Winkelmann).

<https://doi.org/10.1016/j.sandf.2020.11.001>

0038-0806/© 2020 Production and hosting by Elsevier B.V. on behalf of The Japanese Geotechnical Society.

This is an open access article under the CC BY-NC-ND license (<http://creativecommons.org/licenses/by-nc-nd/4.0/>).

In geotechnical RBD the methods employing mean value and variance of each random variable are the most straightforward. The simplest version approximates the limit state functions (LSFs) by either linear (First-Order Reliability Methods – FORM) or quadratic (Second-Order Reliability Methods – SORM) functions (Melchers and Beck, 1999; Nowak and Collins, 2000). The Monte Carlo (MC) method is the most widespread in geotechnical multivariate problems (Cao et al., 2019; Suchomel and Mašín, 2011). Variance reduction techniques are possible here (Fenton and Griffiths, 2008; Phoon, 2014). Sample databases from various MC simulations contribute to the Response Surface (RS) approximation (Hohenbichler and Rackwitz, 1988). The Point Estimate Method (PEM), in its form presented in (Rosenblueth, 1975), is also popular in geotechnical reliability assessment (Ahmadabadi and Poisel, 2015; Baecher and Christian, 2003; Suchomel and Mašín, 2011). Limitations of PEM arise in multivariate cases, attempts to optimize computational time and accuracy have been undertaken (Harr, 1989; Hong, 1998).

Reliability estimation of multi-layered soils concerns the proper choice of probabilistic methodology and relevant selection of constitutive soil models applied in deterministic approaches. The paper (Wu et al., 1993) reviews the hyperplastic models of soils addressing typical errors in FEM modelling. The augmented Mohr-Coulomb (M–C) models are the most popular in computations (Coombs et al., 2013). The available software incorporates advanced models too, e.g. the Hardening Soil (HS) model (Schanz et al., 1999).

The paper addresses the reliability change of a road bridge pile foundation during structural operation. The means are proposed to extrapolate foundation reliability to satisfy the limit given in EN 1990:2002/A1:2005 (EN, 2002). The analysis is illustrated by design outlines and monitoring results of the Rędziński Bridge in Wrocław, Poland (Biliszczuk et al., 2016). The foundation-subsoil system FE model generated in ZSoil® is discussed in detail.

The bridge foundation experiences strong settlement increase, whose origins are difficult to define and quantify, e.g.: a multitude of soil layers, difficult site hydrogeological conditions, and construction process complexity. The authors proposed to attribute this complex process to a specific change in the representative stiffness of the subsoil, expressed by the HS model-oriented soil secant elastic moduli E_{ur}^{ref} of each key soil strata. The calculations are simplified, based on settlement sensitivity to these moduli change.

First of all, the initial SLS-based foundation reliability is parallelly investigated using two methods – the PEM and the RSM. Next, the assessed Hasofer-Lind reliability index is related to its standard-based limit. The foundation settlements are investigated in the first year of bridge operation, in joint terms of their real-life survey and corresponding SLS reliability.

While the anticipated bridge operation is affected by increasing settlements, an innovative fluctuation function in time domain $n(t)$ to capture the predicted settlement increase and the reliability descent is proposed. The time-variant approach supports future remedial actions to maintain the initial reliability, indicating their frequency and scope (short-time interventions or long-term repairs).

These proposed fluctuation functions $n(t)$ make it possible to extrapolate e.g. the 5-year or 50-year reliability levels. The conducted reliability estimation may be verified, as for the Rędziński Bridge, the data from Structural Health Monitoring (SHM) system (Klikowicz et al., 2016) is available for foundation settlements for the first five years of operation. This example shows that the proposed approach is correct and applicable.

2. The analysed pile foundation of a road bridge pylon

The investigated pile foundation is a part of the second-largest cable-stayed bridge in Poland, the Rędziński Bridge in Wrocław (Biliszczuk et al., 2012), presented in Fig. 1.

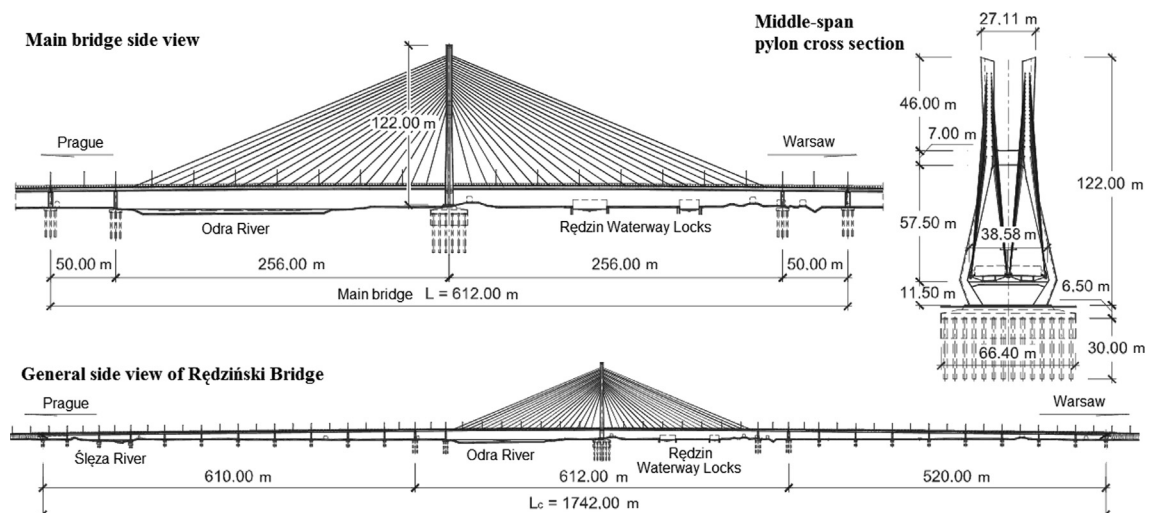

Fig. 1. The Rędziński Bridge overview (Biliszczuk et al., 2012).

The bridge superstructure consists of two separate prestressed concrete box girders, suspended to an H-shaped hybrid pylon (part concrete, part steel–concrete composite). The pylon foundation is a concrete massive slab, its base dimensions are 67.4×28.0 m with variable thickness (2.5 to 6.5 m), supported on 160 reinforced concrete piles (8 rows of 20 piles, in a 3.4×3.6 m rectangular grid), each 18.0 m long and 1.5 m in diameter. The pile foundation is presented in Fig. 2.

The foundation has been previously analysed in (Dembecki and Krasinski, 2013), due to complex hydrogeological conditions at the construction site. The subsoil comprises of seven distinct layers. The layer (IIa/IIb) of normally consolidated river accumulations lies on three layers (IIIa, IIIb, IIIc) of dense coarse material, with an unconfined water table at the elevation of 107.5 m a.s.l. Below them, a layer (Va) consisting of fine soils (clays, silty sands) with local water percolations is observed. It contains two thin lentils (Vc) of silty sands – both with a confined water table under high pressure situated on top of them, at 89.0 m a.s.l. and 71.0 m a.s.l., respectively. No weak soils are present to the elevation of 52.8 m a.s.l. The Va layer is classified as the most relevant one, due to its high thickness (in two appearance levels) as well as lower stiffnesses and strength parameters than those of the grained soils of IIIa, IIIb, IIIc, and Vc layers. Moreover, the geotechnical conditions of the Va layer are compromised by local water percolations and high water pressures in confined aquifers.

The detailed physical and mechanical properties of the hydrogeological profile layers, determined in the tests of (Dembecki and Krasinski, 2013) are given in Table 1.

3. The FE model of the pile foundation

Computations of foundation settlements were performed in ZSoil[®] system (Commend et al., 2014) assuming geometric and material non-linearity. Two numerical models of the foundation were generated to represent two cross-sections presented in Fig. 2. Both parallel (left) and perpendicular (right) cross-sections were separately analysed. The generated perpendicular model is presented in Fig. 3.

The numerical models of the soil–foundation subsystem were implemented in a plane strain regime, introducing stiffness corrections in order to automatically account for pile spacing. Quadrilateral, 4-node continuous elements were applied to form a two-dimensional (2-D) soil FE mesh. The piles were modelled as beam elements, rigidly fastened to the slab. Their weight was assumed to reflect the difference between the specific weight of concrete of the piles and soil specific weight in the pile contact zones.

The numerical routines incorporate the augmented Mohr–Coulomb (M–C) model and a higher-order Hardening Soil (HS) model. The M–C model is a well-known linearly elastic and ideally plastic model often applied to initially approximate the soil response. In its augmented variant, given in (Coombs et al., 2013), it is formulated in a non-associated plasticity framework. In the paper, the M–C constitutive model was applied for three top unsaturated, low-cohesive strata IIa, IIb, and IIIa (Table 1, Fig. 3). These layers are situated over the pile–slab connection level, thus they may be identified as an indirect form of a dead load, with negligible influence on the key subsoil response.

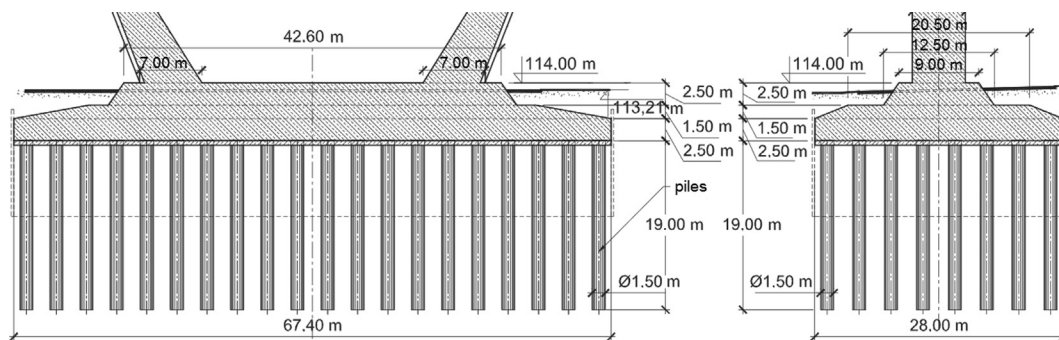

Fig. 2. The cross-sections of the Rędziński Bridge pile foundation (Biliszczyk et al., 2012).

Table 1
Soil strata layout of the Rędziński Bridge subsoil (Dembecki and Krasinski, 2013).

Layer	Soils present	Top	Bottom
IIa, IIb	clay, loamy clay, loam	112.8 m.a.s.l.	110.0 m.a.s.l.
IIIa	fine, medium and coarse sands	110.0 m.a.s.l.	107.5 m.a.s.l.
IIIb	medium and coarse sands with gravel mixes	107.5 m.a.s.l.	105.5 m.a.s.l.
IIIc	gravel mix, gravel and coarse-sands with gravel mixes	105.5 m.a.s.l.	103.5 m.a.s.l.
Va	loam, silty loam, silty boulder clay, boulder clay	103.5 m.a.s.l.	89.0 m.a.s.l.
Vc	silty sand	89.0 m.a.s.l.	87.0 m.a.s.l.
Va*	loam, silty loam, silty boulder clay, boulder clay	87.0 m.a.s.l.	—

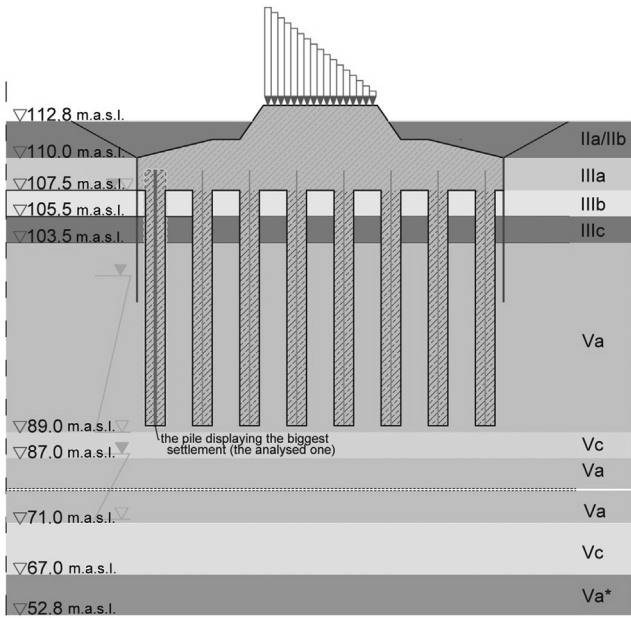

Fig. 3. The generated perpendicular model at loading activation time step.

The explicit HS model predicts precisely the structure–soil interaction by capturing the stress–strain relation in the subsoil and acquiring a wide database on soil plastic behaviour (including soil dilatancy and yield cap). It describes relevant soil stiffnesses as functions of mean effective stress level (Cudny, 2013; Obrzud and Truty, 2018; Schanz et al., 1999). The HS model was chosen here to analyse strata IIIb, IIIc, Va, Va*, and Vc (Table 1, Fig. 3), situated under the foundation bottom. The values of HS model reference stiffness parameters were adopted on the basis of the tri-axial tests on small strain stiffness moduli performed by (Dembicki and Krasinski, 2013). The key parameter values are presented in Table 2.

Hydrogeological conditions are modelled as two stabilized water levels in the layer Vc. In the impermeable Va layer, the hydrostatic pressure from the Vc layer was applied (Fig. 3). The soil pore pressure is taken into account directly in the calculation of the effective stresses of the subsoil. In all layers, the zero dilatancy angle was assumed $\psi = 0^\circ$. The preconsolidation ratio (OCR) was taken 1.0 for layers IIIb and IIIc and 2.0 for layers Va, Va* and Vc, in accordance with (Dembicki and Krasinski, 2013).

The concrete of foundation slab and piles was adopted as linearly elastic with the following material parameters: Young's modulus $E_c = 30 \cdot 10^7$ kPa, Poisson's ratio $\nu = 0.1$, and specific weight $\gamma_c = 24$ kN/m³. Concrete creep was neglected in further calculations because of its negligible impact on the foundation settlement.

Nine construction stages were analysed in the FE model: the initial scenario of a flat surface at 112.8 m a.s.l., the excavation to 110.0 m a.s.l., the sheet wall driving, the deeper excavation to 107.0 m a.s.l., the driving of the piles, the casting and hardening of the concrete, the introduction of dead loads of the pylon and the deck, and the introduction

of variable traffic loads in all most unfavourable combinations. The final construction stage is presented in Fig. 3.

In the FE model, the stiffnesses and specific weights of groups of 1-D or 2-D finite elements are modified to reflect the operations performed in subsequent construction stages – either reduced to infinitesimal values if excavations are carried out or adjusted to match the concrete parameters if concrete works are conducted. The addition of the sheet walls and piles is simulated by introducing appropriate 1-D FE with set stiffnesses and specific weights.

All analysed construction stages considered the drained conditions of all layers, no additional overpressure was generated. Such an approach seems realistic accounting for a relatively low bridge construction speed.

The analysis of the most unfavourable dead and live loads characteristic combination is necessary to determine the extreme settlements in the final construction stage. The database on the combination, i.e. the dead and live loads, the envelopes of support reactions, and key internal forces were acquired from the outlines of Rędziński Bridge designers, presented in e.g. (Biliszczyk et al., 2014, 2016) and several minor technical reports in Polish-language civil engineering periodicals. The most unfavourable bulk pressure function $q(d)$ was determined on this basis (see Fig. 3):

$$q(d) = -2.8587d + 26.79 \text{ [MN/m]} \quad (1)$$

where d [m] denotes the distance from the left-side edge of the pylon.

In its analytical scope the work addresses the assessment of key settlements of the pile–foundation subsystem (vertical displacements at the pile head level). In the course of FE preliminary analysis, the displacements and rotations of the foundation indicate a rigid motion of the slab; its bottom surface remains flat in the deformed configuration. Displacement identification is based on a simple data extrapolation from two distinct FE models (representing both cross-sections) to each point on the foundation bottom. The left-corner pile exhibits the highest settlement of 0.080 m (Fig. 3). As the final analytical goal focuses on the probabilistic approach of a high numerical cost, further inquiries were limited to the analysis of the perpendicular model only (Fig. 3), and the assessment concerned only the extreme left–corner pile displacement.

It should be noted, that although many simplifications of the model were applied, they have an unnoticeable effect on the quality and accuracy of the obtained key results of the structural response, and they reflect the foundation mechanical behavior regarding general engineering experience. The calculated numerical settlements were confirmed by the respective survey results (0.0808 m), available from the geodetic monitoring of six nodes of the slab (at four corners and two middle nodes of longer edges).

4. Adoption of the input random variables

The paper attempts to create a FE model to effectively describe the settlements of a structural foundation over a

Table 2
Characteristic subsoil strata parameters.

Layer	Volum. weight γ/γ' [kN/m ³]	Effect. internal friction angle ϕ' (°)	Effect. cohesion c' (kPa)	Oedom. modulus M_0 (kPa)	Poisson's ratio ν [-]	Reference oedom. modulus M_o^{ref} (kPa)	Sec. mod. at 50% of max. dev. stress E_{50}^{ref} (kPa)	Secant modulus for soil loading E_{ur}^{ref} (kPa)	Reference preconsolidation p^{ref} (kPa)	Reference mod. depend. on stress level m (-)
IIa	21.0/11.0	15.0	5.0	30 000	0.20	—	—	—	—	—
IIb	21.0/11.0	15.0	5.0	30 000	0.20	—	—	—	—	—
IIIa	19.0/10.0	33.0	1.0	85 000	0.20	—	—	—	—	—
IIIb	20.0/10.0	35.0	1.0	150 000	0.15	140 000	110 000	250 000	100	0.5
IIIc	20.0/10.0	35.0	1.0	220 000	0.15	150 000	100 000	300 000	100	0.5
Va	21.5/11.5	23.0	18.0	40 000	0.20	40 000	35 000	100 000	100	0.5
Va*	21.5/11.5	23.0	18.0	100 000	0.20	100 000	70 000	200 000	100	0.5
Vc	20.5/11.0	32.0	1.0	85 000	0.15	85 000	75 000	150 000	100	0.5

period of several years. The model is probabilistic, as it requires the definition of random variables to govern the course of the settlement process. Only one parameter was selected for this purpose, the soil secant unloading/reloading elastic modulus at a given reference stress level, E_{ur}^{ref} . It is the basic input parameter of the HS model in ZSoil® numerical software. This variable is intended to capture time variation of individual soil stiffness parameters, alongside the overall structural over-settlements.

The advanced FEM software allows to comprehensively analyse a multitude of factors that affect structural settlements, e.g. the subsoil-pile system geometry, arching, the coefficient of skin friction, pile spacing, the pile cap width, the pile to subsoil modulus ratio on the vertical stress-settlement response, and many others (e.g. Rui et al., 2020). However, the encapsulation of all these factors in a single FE model is very difficult. It is even more problematic in the case of probabilistic approach consideration, which requires a broader in situ measurement database, as compared to the one needed in the deterministic analysis (Frantziskonis and Breyse, 2003). Thus, if dominant origins of foundation settlement cannot be identified, a holistic approach is to be rather pursued, allowing for the conduction of a properly simplified structural analysis. Such a scenario is the subject of the presented analysis, therefore a single substitute parameter is defined – the abovementioned E_{ur}^{ref} modulus. Its time-dependent variation is bound to reflect any and all factors leading to over-settlements.

As the HS model connects all nonlinear soil parameters, the variation introduced in E_{ur}^{ref} affects the required secant reference elastic modulus at 50% of the M–C ultimate deviatoric stress q_f (E_{50}^{ref}), the oedometric tangent modulus (E_{0ed}), and other stiffness-related parameters. Any soil investigated by the HS model is assumed homogeneous.

Due to a complex, multi-layered subsoil, geotechnical profile variation in E_{ur}^{ref} moduli is distinguished in each respective soil strata of the HS model, hence not regarded as a universal variable of the entire model. Five random variables reflecting the E_{ur}^{ref} moduli change are adopted in the task, all of them are assumed Gaussian. Their respective mean values $\mu_{x_i} \equiv E_{ur}^{ref}|_i$ are consistent with the data from (Dembicki and Krasinski, 2013), see Table 2. The same coefficient of variation $v_{x_i} = 0.1$ was applied for all variables, in compliance to (Phoon et al., 2006; Suchomel and Masin, 2011), thus the respective standard deviations are $\sigma_{x_i} \equiv 0.1 \mu_{x_i}$. All statistical parameters of initial random variables are collected in Table 3.

5. Sensitivity analysis to the soil secant elastic modulus variation

Probabilistic analysis starts with the identification of the impact of stiffnesses of individual strata on the total foundation settlement. In real-life engineering, such sensitivity

analysis allows for correction or optimization of the foundation design.

The pile settlements were computed in a series of numerical model simulations, where one variable was adopted with its mean value corrected by one $x_i = \mu_{x_i} \pm \sigma_{x_i}$ or three standard deviations $x_i = \mu_{x_i} \pm 3\sigma_{x_i}$, the mean values of other variables were left unchanged, see Table 3. Thus, 20 different FE samples were created. This approach coincides with One-At-A-Time (OAT) technique (Hamby, 1994). The results of the sensitivity analysis are presented in Fig. 4.

The analysis shows an approximately linear change of pile settlements parameters over the entire $\pm 3\sigma_{x_i}$ range. The detailed information on the settlement change in the $(\mu_{x_i} \pm \sigma_{x_i})$ range for all variables is collected in Table 4.

Owing to the obtained data, the percentage impact factors of respective variables on the overall settlement was assessed as

$$\alpha_i = \frac{\Delta y(x_i)}{\Delta y(\Sigma x_i)} \times 100\% \quad (2)$$

and given in Table 4.

The sensitivity analysis indicates the $X_3 = E_{ur}^{ref}|_{Va}$ variable of the greatest impact on overall displacements of the foundation, it justifies the observations of (Dembicki and Krasiński, 2013). Variables $X_4 = E_{ur}^{ref}|_{Va*}$ and $X_5 = E_{ur}^{ref}|_{Vc}$ show a lower impact here than X_3 , while the influence of higher strata, represented by variables $X_1 = E_{ur}^{ref}|_{IIIb}$ and $X_2 = E_{ur}^{ref}|_{IIIc}$ is negligible. Thus adopting a simpler M–C model for the top strata (IIa, IIb, and IIIa) is justified, without any effect on settlements.

Upon comparing the obtained α_i values, a possible reduction of the number of basic random variables of the problem seems possible. Thus in reliability assessment, two cases were initially regarded for comparative purposes: adopting either all five variables or only the three variables with the biggest impact on settlements (X_3, X_4, X_5).

6. Standard SLS-based reliability assessment of a pile foundation

When designing structures, validating all Ultimate Limit State (ULS) and Serviceability Limit State (SLS) criteria is mandatory. In the case of most bridge foundations, verification of the SLS becomes crucial. The structural response is in turn compared with predefined limit values set either by the national standards (in accordance with the structural type) or designers (to match the preliminary assumptions on the demanded serviceability).

In the case of Rędziński Bridge, the SLS limit value of $u_{lim} = 0.10$ m was applied by the designers. This value is not related to any structural failure (the collapse of the bridge superstructure) but is determined by acceptable tolerance of road grade line positioning stated by national regulations, the Technical Conditions issued by the Min-

istry of Infrastructure in Poland (Żółtowski, 2012) in this case. Adopting the same limit value $u_{lim} = 0.10$ m for the reliability analysis of settlements seems reasonable.

On the basis of the deterministic analysis, the left-edge pile was indicated as the one undergoing maximum settlements in the entire pile formation (Fig. 3). Thus, only this variate extreme key displacement (y_{extr}) will be referred to the limit value (u_{lim}), resulting in a simple formulation of the final SLS criterion, $y_{extr} \leq u_{lim}$.

6.1. The basics of PEM and RSM joint approach to reliability analysis

This paper benefits from the idea presented in e.g. (Owerko et al., 2019) to conduct the reliability analysis using a joint approach of the Point Estimate Method (PEM) and the Response Surface Method (RSM). In the case of Rędziński Bridge, such a joint approach is feasible, due to the detected linear sensitivity of random variables to the variation in soil secant elastic moduli, see Fig. 4. A parallel application allows for a cross-check of the reliability estimators assessed with both approaches, with no additional numerical cost (RSM re-uses the same data needed to complete the PEM calculations).

The main goal of the PEM is to replace a continuous random variable description with a discrete one, consisting of samples assumed their probability distribution (Rosenblueth, 1975, Hong, 1998). In the case of an n random variables ($\mathbf{x} = (x_1, x_2, \dots, x_n)$), the limit state function y reads

$$y \equiv y(\mathbf{x}) = y(x_1, x_2, \dots, x_n) \quad (3)$$

The entire set of $[y(\mathbf{x})]_i$ values is computed in the combination of 2^n PEM discretization points. The mean value μ_y and the standard deviation σ_y are specified (Rosenblueth, 1975)

$$\mu_y \cong \frac{1}{2^n} \sum_{i=1}^{2^n} [y(\mathbf{x})]_i \quad (4)$$

$$\sigma_y \cong \sqrt{\frac{1}{2^n} \sum_{i=1}^{2^n} [y(\mathbf{x})]_i^2 - \mu_y^2} \quad (5)$$

The PEM-based reliability index, defined by (Cornell, 1971), is estimated in the form

$$\beta_{PEM} = \mu_y / \sigma_y \quad (6)$$

It should be emphasised, that the $[y(\mathbf{x})]_i$ results obtained in the sensitivity analysis may be directly re-used in the PEM computations.

The RSM approximates the actual structural response function $\hat{y} \equiv \hat{y}(\mathbf{x})$ to the variation in random input parameters $y \equiv y(\mathbf{x})$, according to

$$\hat{y} \equiv \hat{y}(\mathbf{x}) = y(x_1, x_2, \dots, x_n) + \varepsilon \quad (7)$$

where ε is the assessment error of the actual structural response.

Table 3
Statistic material parameters of layer-wise HS model.

Variable	Layer	Mean value μ_{x_i} [kPa]	Variation v_{x_i}	Standard deviation σ_{x_i} [kPa]	$\mu_{x_i} - \sigma_{x_i}$	$\mu_{x_i} + \sigma_{x_i}$	$\mu_{x_i} - 3\sigma_{x_i}$	$\mu_{x_i} + 3\sigma_{x_i}$
X ₁	IIIb	250 000	0.1	25 000	225 000	275 000	175 000	325 000
X ₂	IIIc	300 000	0.1	30 000	270 000	330 000	210 000	390 000
X ₃	Va	100 000	0.1	10 000	90 000	110 000	70 000	130 000
X ₄	Va*	200 000	0.1	20 000	180 000	220 000	140 000	260 000
X ₅	Vc	150 000	0.1	15 000	135 000	165 000	105 000	195 000

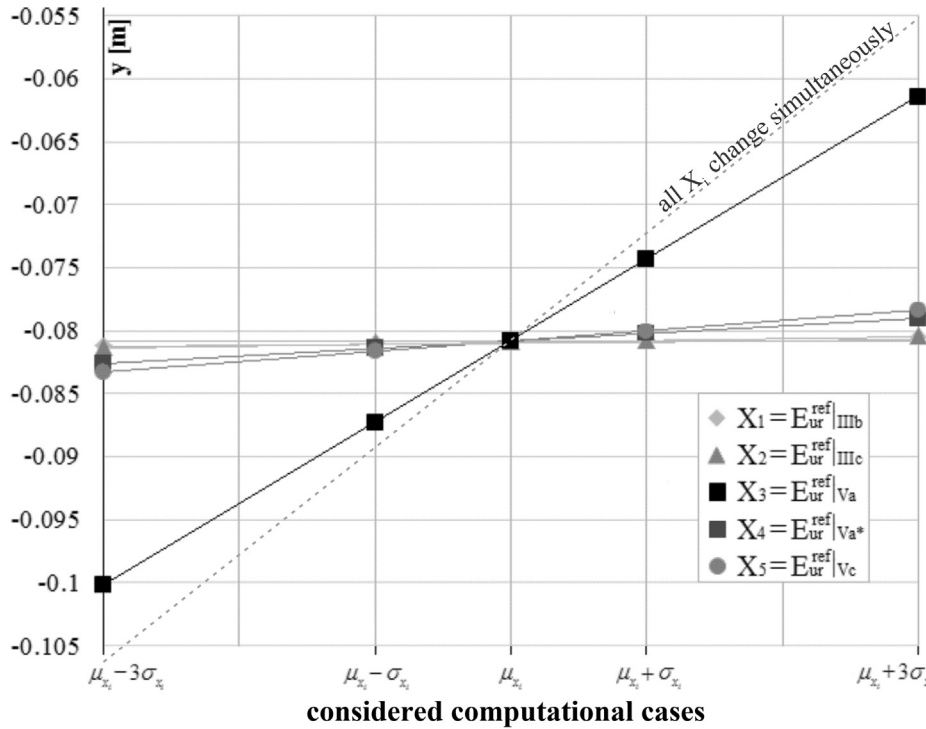

Fig. 4. Initial time-step sensitivity analysis of pile foundation settlements to the variation in soil secant elastic moduli of respective soil strata.

Table 4
Extreme displacements of pile foundation due to the change in soil strata secant elastic moduli.

Displacements	Change in the layer-wise soil secant elastic moduli					
	all layers at once	only in IIIb $\mu_{x_1} \mp \sigma_{x_1}$	only in IIIc $\mu_{x_2} \mp \sigma_{x_2}$	only in Va $\mu_{x_3} \mp \sigma_{x_3}$	only in Va* $\mu_{x_4} \mp \sigma_{x_4}$	only in Vc $\mu_{x_5} \mp \sigma_{x_5}$
$y_{\min}(y \text{ for } \mu_{x_i} - \sigma_{x_i})$	-0.0889 m	-0.0801 m	-0.0801 m	-0.0870 m	-0.0807 m	-0.0810 m
$y_{\max}(y \text{ for } \mu_{x_i} + \sigma_{x_i})$	-0.0727 m	-0.0800 m	-0.0799 m	-0.0742 m	-0.0794 m	-0.0792 m
$\Delta y = y_{\max} - y_{\min} $	$\Delta y(\Sigma x_i) = 0.0162 \text{ m}$	$\Delta y(x_1) = 0.0001 \text{ m}$	$\Delta y(x_2) = 0.0002 \text{ m}$	$\Delta y(x_3) = 0.0128 \text{ m}$	$\Delta y(x_4) = 0.0013 \text{ m}$	$\Delta y(x_5) = 0.0018 \text{ m}$
α_i	-	0.62%	1.23%	79.01%	8.02%	11.12%

While the impact of all individual variables is linear the response approximation may involve the first-order polynomial model

$$\hat{y}(\mathbf{x}) = b_0 + \sum_{i=1}^n b_i x_i + \varepsilon \tag{8}$$

To assess the surface elevation factor b_0 and gradient factors b_i , the ANOVA tabular variance reduction technique is used, see (Montgomery, 1997) incorporating the least square method to minimize the possible lack-of-fit

ratio in all approximation nodes. The surface factors are determined with the help of RSM-Win© (Winkelmann and Górski, 2014).

The RSM-based reliability index β_{HL} is estimated by procedures given in (Lind and Hasofer, 1974). The iterative procedure of the index determination pursues a relevant design point \mathbf{x}^* , defining the shortest distance from the initial structural state to the failure surface, in the standardized space of basic variables. This distance is then adopted as the index value

$$\beta_{HL} = \min_{g(\mathbf{x})=0} \beta(\mathbf{x}) = \min_{g(\mathbf{x})=0} \sqrt{(\mathbf{x} - E[\mathbf{x}])^T C_x^{-1} (\mathbf{x} - E[\mathbf{x}])} \quad (9)$$

where $E[\mathbf{x}]$ is a mean value vector of a random variable \mathbf{x} and C_x is its covariance matrix. The $g(\mathbf{x}) = 0$ stands for the limit state equation (LSE) – the hyperline in the variable space which separates the safety and failure regions.

The key issue of the RSM procedure is the proper selection of points approximating the response function $\hat{y}(\mathbf{x})$. Considering the results of the sensitivity analysis shows a linear impact of all variables on the model response (Fig. 4), thus the RSM routine incorporates the PEM points. The interrelation of PEM and RSM significantly shortens the computational time, which is decisive in advanced FEM models.

6.2. The SLS-based reliability index calculation

On the basis of the sensitivity analysis (see Chapter 4) the reduction of the number of random variables was possible. Thus, the scenarios of the reliability assessment due to bridge settlements concern a total of either all five or three variables of the biggest influence on the structural response.

The first scenario incorporating five variables uses 32 samples in PEM computations. A set of $2n = 2 \times 5 = 10$ samples required for PEM calculations is identical to the ones used in standard ($\pm\sigma_{x_i}$) sensitivity analysis. Thus we consider only $2^n - 2n = 32 - 10 = 22$ samples linked with variability combination in further FE model calculations. Applying Eqn. (4) ÷ (6) the reliability index $\beta_{PEM-5} = 2.929$ was estimated. The same set of 32 samples was re-used to approximate the first-order response surface, defined by Eqn. (8), hence no additional computations are required. The following form of the structural response $\hat{y}(\mathbf{x})$ (the largest settlement of the foundation slab, displayed by its left-corner node) was estimated

$$\hat{y}(\mathbf{x})_{RSM-5} = -1.62 \times 10^{-1} + 4.55 \times 10^{-9}x_1 + 5.04 \times 10^{-9}x_2 + 6.46 \times 10^{-7}x_3 + 2.98 \times 10^{-8}x_4 + 5.43 \times 10^{-8}x_5 \quad (10)$$

This allows for the determination of the Hasofer–Lind reliability index $\beta_{RSM-5} = 2.946$. A slight difference between the PEM and RSM results is observed (about 0.577%).

While only three variables are considered the number of PEM samples equals 8. The PEM-based reliability index

$\beta_{PEM-3} = 2.928$. The same set of 8 samples allows forming the first-order response surface, in the following form

$$\hat{y}(\mathbf{x})_{RSM-3} = -1.59 \times 10^{-1} + 6.42 \times 10^{-7}x_3 + 2.96 \times 10^{-8}x_4 + 5.48 \times 10^{-8}x_5 \quad (11)$$

which results in a reliability index of $\beta_{RSM-3} = 2.936$ (a 0.272% difference to PEM).

While no relative difference of β_{PEM-3} and β_{PEM-5} occurs, regarding the need to make the computational cost lower, the reduction of the random problem to three variables is justified. Thus, the index value $\beta = \beta_{PEM-3} = 2.928$ is adopted as the final result of the SLS-based reliability assessment.

6.3. Verification of the reliability index admissibility due to design standards

Similarly to the simple formulation of the SLS displacement criterion, the reliability index verification may be also defined in a straightforward form of $\beta \geq \beta_{lim}$. It should be noted, that such a simple-form reliability check is recommended by a majority of design standards, as part of the general structural verification under all dead and live loads applied.

The standards define various reference β values, dependent on e.g. the failure consequence class, the structure execution class, and the supervision levels of both design and execution processes. They are also fully related to discerned time periods of a planned non-failure structural operation. Two crucial reference periods are mostly indicated: the 1-year (initial) period (accounting for the general Serviceability Limit State verification) and the 50-year (long-term) period (dedicated for the Ultimate Limit State verification).

Table 5 lists the suggested target reliability indices for these explicit time periods presented in various standards, e.g.: EN 1990:2002/A1:2005 (EN, 2002), EN-ISO 2394:2015 (EN-ISO, 2015), fib Model Code for Concrete Structures 2010 (fib MC, 2012), and JCSS Probabilistic Model Code (JCSS, 2001).

In the real-life design of the Rędziński Bridge, the EN 1990:2002/A1:2005 standard was referenced, obligatory in Poland. In the light of its specification, the anticipated reliability index depends on the planned structural operation time, and on the damage consequence cost/class (CC). As the Rędziński bridge was planned a decisive element in the Wrocław transportation grid, it was classified to CC2

Table 5
Standard-based reliability indices for foundation settlements assuming two adopted periods.

Time-wise reliability check	Calc. index $\beta = 2.928$	Considered standards defining the anticipated reliability indices				
		EN CC3	EN CC2	JCSS	fib MC	EN-ISO
Initial (1-year period)	Adm. value	4.7	2.9	4.2	3.0	1.5
	Fulfilled?	no	yes	no	no	yes
Long-time (50-year period)	Adm. value	3.8	1.5	4.2	1.5	1.5
	Fulfilled?	no	yes	no	yes	yes

(Biliszczyk et al., 2016). Thus, in the initial verification (a theoretical, 1-year scenario of the bridge operation under all dead and exploitation loads), the Rędziński Bridge fulfilled its SLS-based reliability criterion ($\beta = 2.928 \geq \beta_{\text{lim, EN CC2}} = 2.9$) and was allowed for operation.

However, Table 5 shows that the index does not meet the demanded level according to other standards in a 1-year period scenario (the initial reliability is not ensured) or even according to the same standard if a higher CC was assumed.

Therefore it is proposed, that if such an uncertain criterion fulfilment is reached, the time-wise investigation of the long-term structural SLS-based reliability should be performed, with the use of data from in-situ measurements and geodetic monitoring.

7. Time-wise prediction of SLS-based reliability variation

As previously indicated, the settlement variation is attributed to the change in representative soil stiffness parameter E_{ur}^{ref} of each key strata. Sensitivity analysis identifies three soil strata i.e. Va, Va*, and Vc (Fig. 3) of decisive impact on the foundation settlements. Thus the E_{ur}^{ref} moduli of these strata are subjected to time-related variation. The time-related change in the decisive three moduli ($X_3 = E_{ur}^{ref}|_{Va}$, $X_4 = E_{ur}^{ref}|_{Va^*}$, $X_5 = E_{ur}^{ref}|_{Vc}$) at the same time yields an auxiliary time fluctuation function $n(t)$. This function $n(t)$ addressed the percentage change in the two first probabilistic moments of all three variables. The function governs the mean value decrease of the variables, according to

$$\Delta\mu_{x_i}(t) = \mu_{x_i}(1 - 0.01 n(t)) \quad (12)$$

and the increase in all standard deviations of the variables, relative to

$$\Delta\sigma_{x_i}(t) = \sigma_{x_i}(1 + 0.01 \sqrt{|n(t)|}) \quad (13)$$

where: t – time (given in days).

Each random variable x_i of the task becomes time-related, regarding variations of mean values $\mu_{x_i}(t)$ and standard deviations $\Delta\sigma_{x_i}(t)$, by means of the $n(t)$ function. The RSM approximation in Eqn. (8), allows the assessment of the time-variant response

$$\hat{y}(\mathbf{x}(t)) = b_0 + \sum_{i=1}^n b_i x_i(t) + \varepsilon \quad (14)$$

At each time step t_i (in days), the settlement $y(t_i)$ taken in the form of $\Delta y(t)$ function on the basis of real settlement survey forms a left-hand side of Eqn. (14). The survey data are collected in a year range, thus $t_i \in (0, 365)$ [days] in this case. While the real-life settlement occurs in the starting point of the response surface, the substitution results in the following equation

$$\begin{aligned} y(t_i) &= \Delta y(t)|_{t=t_i} = b_0 + \sum_{i=1}^n b_i \Delta\mu_{x_i}(t)|_{t=t_i} \\ &= b_0 + \sum_{i=1}^n b_i \mu_{x_i}(1 - 0.01 n(t_i)) \end{aligned} \quad (15)$$

The fluctuation function $n(t)$ is derived directly on the basis of Eqn. (15). Performing the calculation for each i -th time step (t_i) of the analysis allows for the global approximation of the foundation response function.

Incorporating the Hasofer–Lind procedures it is possible to forecast the future reliability index decrease. The procedure makes it possible to extrapolate the trends of settlement increase or reliability decrease in subsequent years, based on measurements made in the first year of bridge operation. In order to predict future reliability levels, the proposed approach specifies the time and extent of remedial actions to compensate for the reliability decrease due to over-consolidation.

7.1. SLS-based reliability decrease of Rędziński bridge in the 1-year period

In the case of Rędziński Bridge the fluctuation function $n(t)$, see Eqn. (15), may be determined by means of the geodetically surveyed change checked during the first year of the bridge operation. Three measurements have been provided, as shown in Fig. 5.

On day 0 (3rd September 2011, see Fig. 5), the largest settlement of the foundation slab (displayed by the left-edge one on the perpendicular section, denoted by number 5 in Fig. 5) was 0.0600 m, in the day 229 it was equal to 0.0780 m, next it rose to 0.0808 m in day 369 (ca. one year).

As it is presented in Fig. 5, a significant settlement change occurs in the first year of bridge operation, it can be approximated by a cubic polynomial

$$\Delta y(t) = -1.858 \times 10^{-10} t^3 + 2.718 \times 10^{-7} t^2 - 1.329 \times 10^{-4} t \quad (16)$$

Introducing time t into Eqn. (11)

$$\begin{aligned} \hat{y}(\mathbf{x}(t))_{RSM-3} &= -1.59 \times 10^{-1} + 6.42 \times 10^{-7} x_3(t) \\ &+ 2.96 \times 10^{-8} x_4(t) + 5.48 \times 10^{-8} x_5(t) \end{aligned} \quad (17)$$

Next, substituting the real-life displacements and the $n(t)$ function to the RS equation (15), results in

$$\begin{aligned} y(t_i) &= -1.59 \times 10^{-1} + (1 - 0.01 n(t_i)) [6.42 \times 10^{-7} \mu_{x_3} \\ &+ 2.96 \times 10^{-8} \mu_{x_4} + 5.48 \times 10^{-8} \mu_{x_5}] \end{aligned} \quad (18)$$

hence the $n(t_i)$ is determined according to every time step and approximated to a universal form

$$\begin{aligned} n(t) &= 2.372 \times 10^{-7} t^3 - 3.469 \times 10^{-4} t^2 + 1.697 \\ &\times 10^{-1} t - 27.237 \end{aligned} \quad (19)$$

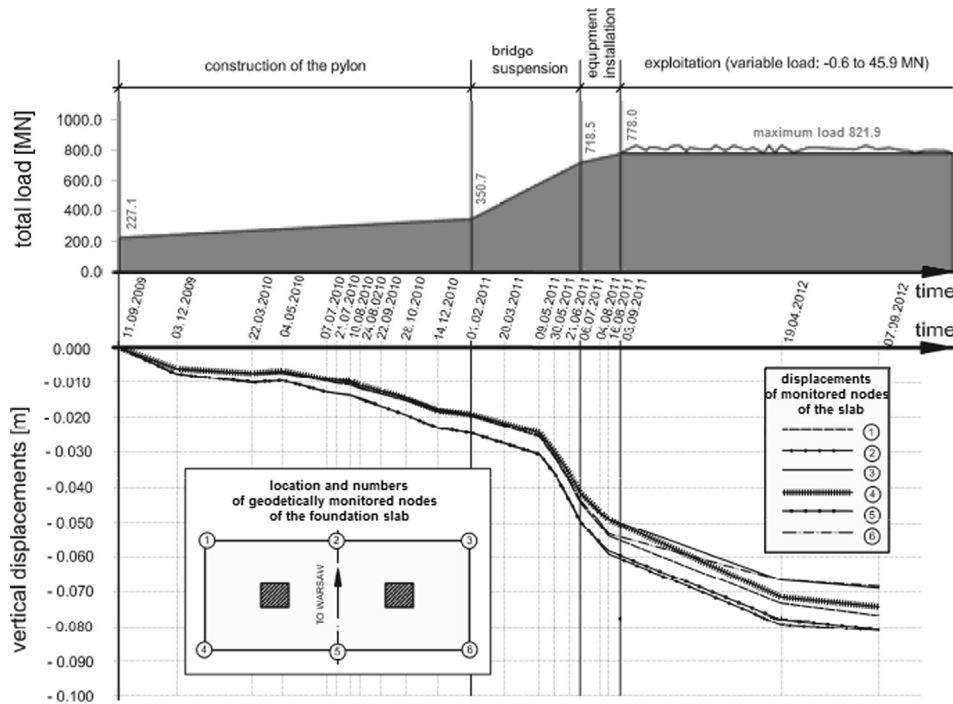

Fig. 5. Geodetically surveyed change in foundation settlements during the bridge construction stage and in its first operation year (Dembecki and Krasinski, 2013).

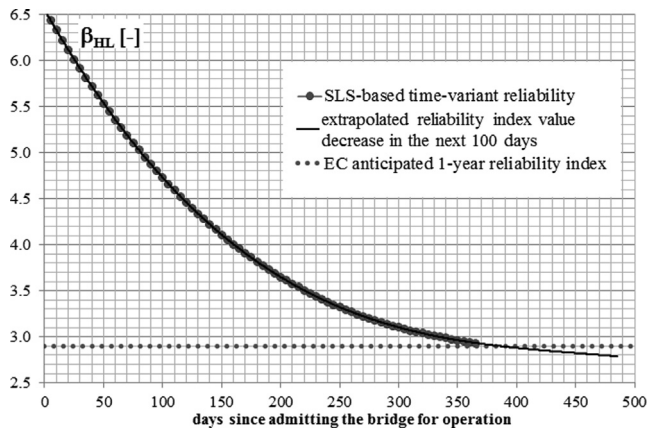

Fig. 6. Assessment of SLS reliability index decrease over the first year of the Rędziński Bridge operation.

The settlement increase is permanent (see Fig. 5), thus it is important to extrapolate the reliability decrement. Taking the time step $t = 730$ (two years from the bridge operation start) the extreme settlement is bound to increase to 0.0844 m. In turn, Eqn. (19) is satisfied with the value of $n(t = 730) = 4.004$. Based on Eqn. (12), mean secant elastic moduli of three respective soil strata reduce to $\mu_{x_3}(t = 730) = 95\,996$ kPa, $\mu_{x_4}(t = 730) = 191\,992$ kPa, and $\mu_{x_5}(t = 730) = 143\,994$ kPa, whereas according to Eqn. (13), their standard deviations increase to $\sigma_{x_3}(t = 730) = 10\,200$ kPa, $\sigma_{x_4}(t = 730) = 20\,400$ kPa, and $\sigma_{x_5}(t = 730) = 15\,300$ kPa.

The time-variant response surface equation, given in Eqn. (17), allows for a step-wise determination of the

Hasofer-Lind time-variant reliability indices β_{HL} , according to Eqn. (9)

$$\beta_{HL}(t)_{RSM-3} = -3.483 \times 10^{-8} t^3 + 4.755 \times 10^{-5} t^2 - 2.263 \times 10^{-2} t + 6.554 \quad (20)$$

Variation in the reliability index β_{HL} is displayed in Fig. 6.

It should be noted, that on the 384th day of bridge operation actual reliability reaches the limit value of $\beta_{EN} = 2.9$ stated by EN 1990:2002/A1:2005, provided no accidental loads will appear during the operation.

7.2. Long-term SLS-based reliability of Rędziński bridge

The variation in reliability index β_{HL} defined with (20) may be extrapolated to the following years. However, the SHM system database collected in the first operational year is too scarce, and may possibly trigger an imprecise index approximation. In the Rędziński Bridge case the re-evaluation of the index was performed, including data on pylon settlements up to 4.5 years after the bridge admission date. This operation was made possible by continuous operation of the SHM system. The geodetic measurements complementing the data in Fig. 5, are presented in Fig. 7.

The survey performed on day 893 (after ca. 2.5 years of operation) indicates maximum displacement of 0.1048 m, a value exceeding the set SLS-based limit. The increase in settlements after the first year of operation was significant (0.0240 m over 1.5 years). Later it slows down substan-

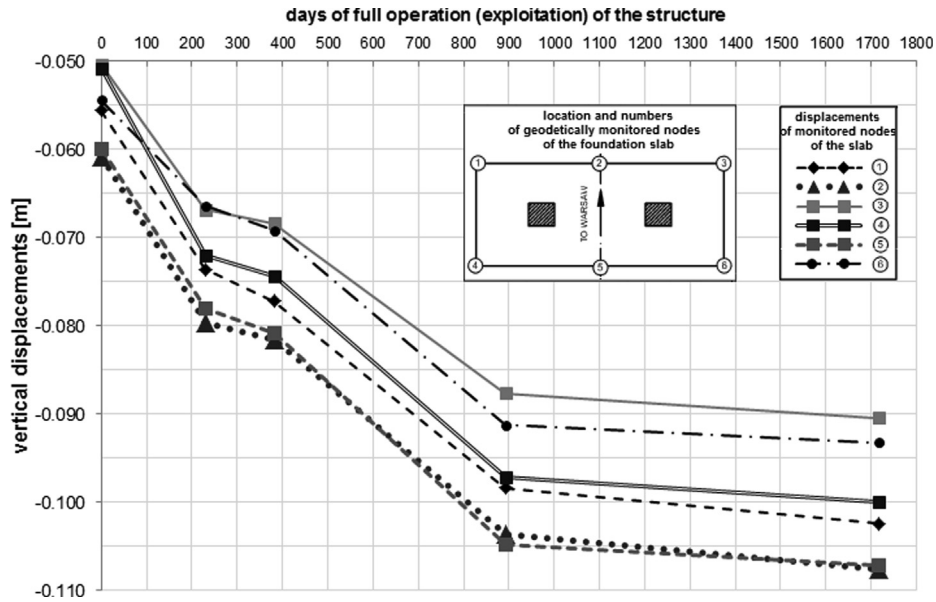

Fig. 7. Geodetically detected change in foundation settlements due to bridge operation in a ca. 4.5 years; the presented measurements are complementary to these presented in Fig. 5.

Table 6
Change in statistic parameters of random variable X_3 in time steps of performed geodetic survey.

Time step	Respective extreme displacement $y(t)$ [m]	Change coefficient $n(t)$	$E_{ur}^{ref} _{V_a}$ mean value μ_{x_3}	$E_{ur}^{ref} _{V_a}$ variation v_{x_3}	$E_{ur}^{ref} _{V_a}$ standard dev. σ_{x_3}
0 (0 days)	-0.0600	-29.652	129 651.5	0.081	9 455.5
1 (229 days)	-0.0780	-9.570	109 570.2	0.094	9 690.6
1-year	-0.0800	0	100 000	0.1	10 000
2 (382 days)	-0.0808	1.082	98 917.9	0.102	10 104.1
3 (893 days)	-0.1048	23.435	76 565.1	0.137	10 484.2
4 (1716 days)	-0.1072	31.867	68 132.8	0.155	10 564.5

tially, reaching a maximum of 0.1072 m in the day 1716 (ca. 4.5 years of operation), an increment of only 0.0026 m over the last 2 years. Incorporating additional data points the adjusted settlement change was approximated as

$$\Delta y(t) = -7.304 \times 10^{-12} t^3 + 4.151 \times 10^{-8} t^2 - 7.782 \times 10^{-5} t \tag{21}$$

In this case, the adjusted fluctuation function $n(t)$ was approximated as

$$n(t) = 9.323 \times 10^{-9} t^3 - 5.299 \times 10^{-5} t^2 + 9.934 \times 10^{-2} t - 29.652 \tag{22}$$

The predefined variation parameters of random variables, their values in time steps of geodetic surveys are defined in Table 6, on the example of $X_3 = E_{ur}^{ref} |_{V_a}$.

In turn, the adjusted Hasofer-Lind β_{HL} reliability index change, expressed by a cubic formula states

$$\beta_{HL}(t)_{RSM-3} = -1.577 \times 10^{-9} t^3 + 7.882 \times 10^{-6} t^2 - 1.341 \times 10^{-2} t + 6.887 \tag{23}$$

As it can be observed, the adjustment of the Rędziński Bridge foundation time-wise reliability index benefits from the addition of the later measurements. It should however be noted, that in cases of other structures, the one-year data may be the sole source of information on the reliability change, and that any additional tests would only be possible upon request and financial expenditure.

7.3. The outcome of long-term reliability analysis – Remedial actions planning

To showcase the outcome of the long-term analysis, the variation of the SLS-based β_{HL} index is presented in Fig. 8 in different scenarios, investigated thereafter.

A purely hypothetical scenario becomes a basis of Fig. 8, showing that if no remedial actions were undertaken, a zero value of the SLS-based foundation reliability would be reached by the descending time-variant function (23) after about 925 days (circa 2.5 years) of bridge operation. This scenario states, that in day 925, the current mean values of $E_{ur}^{ref} |_i$ parameters of respective soil layers would

cause a maximum displacement of the pile foundation equal to the SLS design limit $u_{lim} = 0.10$ m.

The reliability index limit function due to the EN 1990:2002/A1:2005 standard regulations is also shown in Fig. 8 with a dotted line. The graph indicates, that the limit reliability value is also time-variant after the first year of bridge operation. The constant value $\beta_{EN,lim,1} = 2.9$ is adopted only for a 1-year period, then it decreases to $\beta_{EN,lim,50} = 1.5$ over 50 years. The decrement is assessed by means of inverse standard CDF, see Equation (C.3) of EN 1990:2002/A1:2005

$$\Phi(\beta_{EN,lim,Y}) = [\Phi(\beta_{EN,lim,1})]^Y \quad (24)$$

here $\beta_{EN,lim,Y}$ is the limit reliability index in a given point in time Y (in years), $\beta_{EN,lim,1}$ is the 1-year reliability index, and Y denotes the length of the time period (in years).

Additionally, two possible scenarios addressing courses of remedial actions and their resultant influence on the time-variant reliability were graphically presented in Fig. 8.

The first remedial action course is to undertake short-time actions, to maintain the bridge reliability on a 1-year operation level ($\beta = 2.928$). While over-consolidation makes the reliability drop below the value of $\beta_{EN} = 2.9$ demanded by EN 1990:2002/A1:2005, stay cables should restore the 1-year reliability level (proper road grade line elevation). The cable tension control is made possible for Rędziński Bridge due to the installed complex suspension system (Żółtowski, 2012), thus in this case such compensations (short-time actions) can be immediately undertaken with minimum limitation on bridge serviceability. The time steps of these actions are denoted in Fig. 8 by asterisks. As they do not require bridge closure,

the initial reliability index graph is split and vertically elevated in all single-day time steps when the repairs are undertaken (the “short-time” graph in Fig. 8). It should however be noted that the scheme presented in Fig. 8 is theoretical, as its implementation is based on fully controlled, systematic repairs. In real-life engineering, less regular and slightly overcompensated remedial actions should rather be expected. However, this does not impede the proposed procedures.

The second remedial action course concerns undertaking one-time long-term repair, to ensure an identical bridge reliability level to its value of the operation start ca. ($\beta = 6.887$). Given the settlements increment stopping at some point in time, such high reliability provides a proper distance from the EC-based limit. This reliability level may be achieved either by adjustment of bearings, modification of dilatations, or other technologies. Due to the time-consuming nature of such large scale repairs, a temporary bridge closure due to repairs is assumed. An exemplary two-week long repair is adopted and denoted in Fig. 8 by a skewed arrow. The arrow marks the elevation of the initial reliability index graph to the same level that was present in day 0 (the “long-term” graph in Fig. 8).

From the engineering standpoint, one long-term repair is considered advantageous, as the required number of short-time compensations is too big in the case of Rędziński Bridge (over 20 asterisks marking the single-day repairs are proposed, see Fig. 8) and may generate an unacceptably high financial cost. Though, both action courses result in a life-long satisfaction of the SLS criterion, given no further settlement increase is observed after the fifth year of bridge operation, and no accidental loads

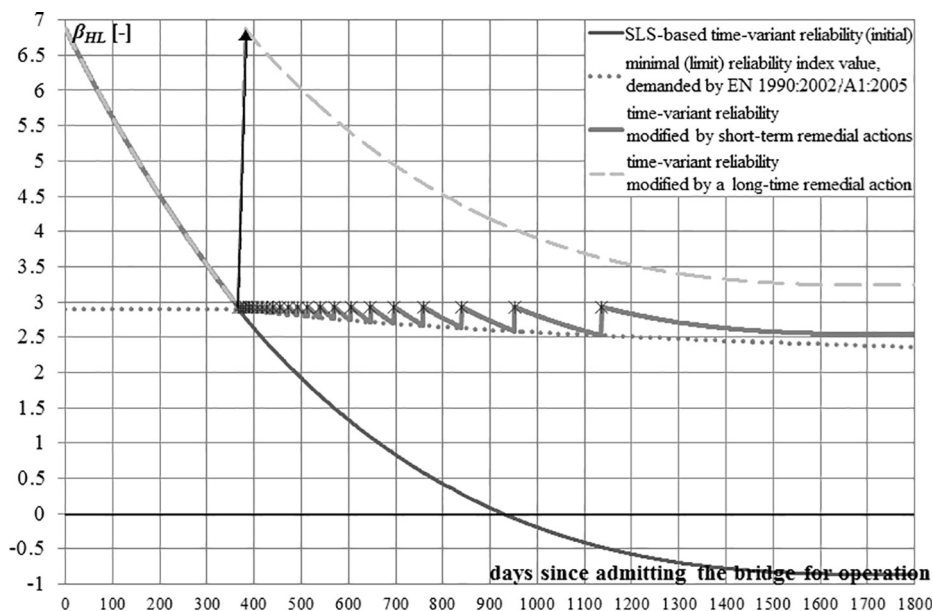

Fig. 8. Long-time assessment of the SLS reliability index decrease based on the real-life continuous geodetic survey of the SHM system.

occur. However, this statement should be supported by subsequent diagnostic structural tests, the continuous operation of the Rędziński Bridge SHM system seems beneficial in this case.

8. Procedure extension to other structural types

A threat of a rapid decrement in the SLS-based reliability in time is induced in many structures of social and infrastructural importance, e.g. bridges, dams, telecommunication towers, wind turbines, buildings with structural roofing, silos, and tanks.

In the majority of such structures, the standard analysis is divided into three main sections. First of all, probabilistic modelling is applied to the initial design stage to account for the variation in structural response induced by uncertainty sources. Secondly, the in-situ investigations are performed to calibrate and adjust the uncertainties' parameters. Thirdly, structural health monitoring systems are implemented to continuously collect and analyse the data on the mechanical response.

The primary goal of the analysis is to predict and observe if the structure shows excessive displacements, thus, is a corresponding unforeseen reliability deterioration

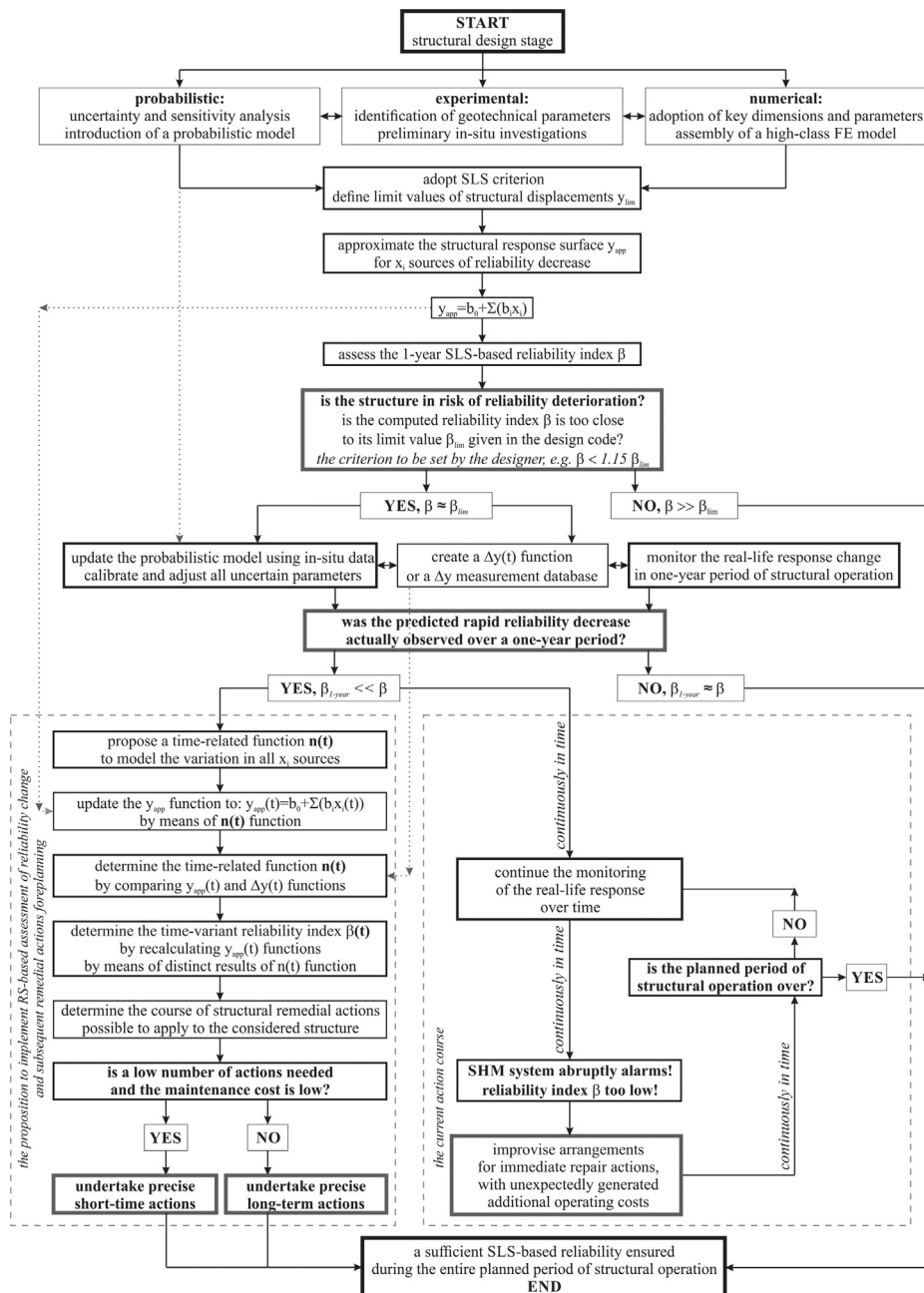

Fig. 9. The process of structural remedial actions administration, complemented by the authors' proposition.

possible. The verification is performed usually over one year, as recommended by the majority of design standards. If a risk of falling below a certain reliability level is confirmed, the structure is bound to undergo a series of remedial actions during its intended time of use.

In real-life engineering, however, any emerging necessities to perform remedial works are indicated only on the basis of the alarming response recorded by the SHM system. The probabilistic output is not used. In turn, maintenance teams are usually obliged to improvise sudden arrangements for immediate works, generated additional operating costs.

Thus, a proposition follows, to conduct an updated reliability assessment using a probabilistic approach, in favour of continuous monitoring.

Upon a sensitivity-based reduction of the number of uncertainty sources (random variables) relevant for a structure under consideration, a response function should be devised. Next, the response approximation function is subjected to a time-dependent alteration, with an application of an auxiliary fluctuation function $n(t)$ to represent the coincident modifications in the parameters of all random variables. This function can be precisely adjusted with the implementation of the SHM system data collected in a finite time period (e.g. one year).

Owing to the presented numerical tool for the approximation of time-dependent reliability, it is possible to foreplan a precisely defined course of remedial actions, of an exact time, frequency, and scope. The output of the procedure may exclude the necessity to continuously use the SHM system after the first year of use, refrain maintenance teams from responding only to emergency situations, and optimize the time and costs of repairs.

It should however be noted, that the presented study is limited to an analysis related to the state of displacements (SLS criterion). The procedure may be adjusted to match other structures, other limit states (e.g. ULS), or other response parameters (e.g. rotations, strains, stresses), although such modifications would require separate analyses.

A flowchart of the current engineering process is devised and presented in Fig. 9. In the figure, an action course benefiting from the proposed probabilistic procedure is highlighted.

9. Conclusions

The paper deals with the assessment of a time-variant RSM-based reliability index for real-life engineering structures and possible applications of this index.

The analysis includes a case study of the Rędziński Bridge in Wrocław, Poland. The bridge foundation is set up in difficult soil conditions, prone to significantly increase structural settlements in time. The advanced numerical model of the slab-pile bridge foundation is assembled in

ZSoil® software. The initial analysis indicated a pile exhibiting the largest displacements.

The most important authors' contribution states that all known and unknown causes of foundation settlement increase are exclusively joined with the variation of soil secant elastic moduli E_{ur}^{ref} . Thus the unique HS modulus E_{ur}^{ref} may be regarded as the representative random stiffness parameter to cover the general settlement of the entire foundation.

Additional standard sensitivity analysis is conducted before the multi-stage reliability estimation in order to conclude if the reduction of the number of variables is possible. Thus the number of numerical simulations is substantially reduced while computing foundation settlements under distinct generated FE foundation models, to no negative effect on the quality of numerical calculations.

Another essential issue is the introduction of an auxiliary fluctuation function $n(t)$ to induce a time-related change of all representative stiffness parameters E_{ur}^{ref} of every distinct crucial soil strata (i). Hence relevant time-related functions of mean values $\Delta\mu_{x_i}(t)$ and standard deviations $\Delta\sigma_{x_i}(t)$ in accordance with $n(t)$, where $X_i \equiv E_{ur}^{ref}|_i$ are proposed. Implementing the fluctuation function $n(t)$ into the RSM allows for the update of foundation settlements in time, consequently, to estimate time-variant structural reliability. The proposed computational algorithm is complemented by determining parameters of the RSM function on the basis of continuous geodetic surveys of real-life settlements, performed throughout bridge construction and operation. It operates well even if a limited in-situ database is provided from a structural monitoring system.

Hence it is possible to accurately estimate the time in which certain remedial actions (either short-time or long-term) are necessary to maintain a satisfactory reliability level of a structure. The authors' complex computations determined periods in which the Rędziński Bridge foundation SLS-based Hasofer–Lind reliability index may fall below the acceptable limit given in chosen design standards.

Owing to the proposed approach, a reduction of the operation time of a structural monitoring system is possible.

Finally, a flowchart is devised to showcase how the authors' proposition enables the replacement of a standard monitoring-based procedure of immediately reacting to exceeding the limit reliability. Nowadays, a continuous looped process is executed of conducting immediate and improvised arrangements only in reaction to monitoring system alarms. As an alternative, the proposition allows for a one-time formulation of a detailed plan of structural repairs to ensure a sufficient reliability over the whole structural operation period. This way, the workload of the maintenance teams may be limited and any related costs may be reduced.

The flowchart applies not only to the case study of the Rędziński Bridge but is rather a general display of the



applicability of the proposed approach. The use of the procedure can be easily extended to other types of structures challenged by the diminishing of operational reliability over time.

References

- Ahmadabadi, M., Poisel, R., 2015. Assessment of the application of point estimate methods in the probabilistic stability analysis of slopes. *Comput. Geotech.* 69, 540–550. <https://doi.org/10.1016/j.compgeo.2015.06.016>.
- Baecher, G.B., Christian, J.T., 2003. *Reliability and statistics in geotechnical engineering*. J. Wiley.
- Biliszczyk, J., Barcik, W., Onysyk, J., Toczkiwicz, R., Tukendorf, A., 2016. The two largest Polish concrete bridges – design and construction. *Proc. Inst. Civ. Eng. - Bridg. Eng.* 169, 298–308. <https://doi.org/10.1680/jbren.15.00015>.
- Biliszczyk, J., Barcik, W., Onysyk, J., Toczkiwicz, R., Tukendorf, A., 2014. Redzinski Bridge in Wrocław - The Largest Concrete Cable-Stayed Bridge in Poland. *Struct. Eng. Int.* 24 (2), 285–292. <https://doi.org/10.2749/101686614X13830790993087>.
- Biliszczyk, J., Onysyk, J., Barcik, W., Prabucki, P., Sułkowski, M., Szczepański, J., Toczkiwicz, R., Tomiczek, M., Tukendorf, A., Tukendorf, K., Ast, A., 2012. Most Rędziński w ciągu Autostradowej Obwodnicy Wrocławia. *Inżynieria i Budownictwo* 68 (2), 63–69.
- Cao, Z.-J., Peng, X., Li, D.-Q., Tang, X.-S., 2019. Full probabilistic geotechnical design under various design scenarios using direct Monte Carlo simulation and sample reweighting. *Eng. Geol.* 248, 207–219. <https://doi.org/10.1016/J.ENGGEOL.2018.11.017>.
- Commend, S., Obrzud, R.F., Podleś, K., Truty, A., Zimmermann, T., 2014. Numerics in Geotechnics and Structures. ZSoil PC: Getting Started. Elmeppress and Zace Services Limited, Lausanne.
- Coombs, W.M., Heaney, C.E., Crouch, R.S., 2013. Observations on Mohr-Coulomb plasticity under plane strain. *J. Eng. Mech.* 139, 1218–1228. [https://doi.org/10.1061/\(ASCE\)EM.1943-7889.0000568](https://doi.org/10.1061/(ASCE)EM.1943-7889.0000568).
- Cornell, A.C., 1971. First Order uncertainty analysis of soils deformation and stability, in: *Proceedings of the First Conference on Applications of Statistics and Probability to Soil and Structural Engineering*. Hong Kong, pp. 130–144.
- Cudny, M., 2013. Some aspects of the constitutive modelling of natural fine grained soils. IMOGEOR, Gdańsk.
- Dembicki, Cudny, Krasinski, Z., 2013. Pylon foundation of a cable stayed bridge at the motorway ring road of Wrocław, in: Pierre Delage; Jacques Desrues; Roger Frank; et al (Ed.), *The 18th International Conference on Soil Mechanics and Geotechnical Engineering*. Paris: Presses des Ponts, DL 2013, Paris, pp. 2715–2718.
- EN 1990:2002/A1:2005. Eurocode: Basis of structural design. CEN – European Committee for Standardization, Brussels, 2002.
- EN-ISO 2394:2015. General principles on reliability for structures. International Organization for Standardization. Geneva, 1998.
- Fenton, G.A., Griffiths, D.V., 2008. *Risk Assessment in Geotechnical Engineering*. John Wiley & Sons Inc., Hoboken, NJ, USA. <https://doi.org/10.1002/9780470284704>.
- Fenton, G.A., Paice, G.M., Griffiths, D.V., 1996. Probabilistic analysis of foundation settlement. *Geotech. Spec. Publ.*, 651–665
- fib (fédération internationale du béton) Bulletin No. 65/66. Model Code 2010, Final draft. International Federation for Structural Concrete. Lausanne, 2012.
- Frantziskonis, G., Breyse, D., 2003. Influence of soil variability on differential settlements of structures. *Comput. Geotech.* 30, 217–230. [https://doi.org/10.1016/S0266-352X\(02\)00062-9](https://doi.org/10.1016/S0266-352X(02)00062-9).
- Hamby, D.M., 1994. A Review of Techniques for Parameter Sensitivity. *Environ. Monit. Assess.* 32, 135–154.
- Harr, M.E., 1989. Probabilistic estimates for multivariate analyses. *Appl. Math. Model.* 13, 313–318. [https://doi.org/10.1016/0307-904X\(89\)90075-9](https://doi.org/10.1016/0307-904X(89)90075-9).
- Hohenbichler, M., Rackwitz, R., 1988. Improvement Of Second-Order Reliability Estimates by Importance Sampling. *J. Eng. Mech.* 114, 2195–2199. [https://doi.org/10.1061/\(ASCE\)0733-9399\(1988\)114:12\(2195\)](https://doi.org/10.1061/(ASCE)0733-9399(1988)114:12(2195)).
- Hong, H.P., 1998. An efficient point estimate method for probabilistic analysis. *Reliab. Eng. Syst. Saf.* 59, 261–267. [https://doi.org/10.1016/S0951-8320\(97\)00071-9](https://doi.org/10.1016/S0951-8320(97)00071-9).
- JCSS Probabilistic Model Code. Part 1 - Basis of Design. Joint Committee on Structural Safety. Zurich, 2001.
- Klikowicz, P., Salamak, M., Poprawa, G., 2016. Structural Health Monitoring of Urban Structures. *Procedia Eng.* 161, 958–962. <https://doi.org/10.1016/j.proeng.2016.08.833>.
- Lind, N.C., Hasofer, A.M., 1974. An exact and invariant first order reliability format. *J. Eng. Mech. Div.* 100, 111–121.
- Melchers, R.E. (Robert E., Beck, A.T., 1999. *Structural reliability analysis and prediction*. Chichester.
- Montgomery, D.C., 1997. *Design and Analysis of Experiments*. John Wiley & Sons Inc, London.
- Nowak, A.S., Collins, K.R., 2000. *Reliability of structures*. New York.
- Obrzud, R.F., Truty, A., 2018. The hardening soil model - a practical guidebook 05, 205.
- Owerko, P., Winkelmann, K., Górski, J., 2019. Application of probabilistic tools to extend load test design of bridges prior to opening. *Struct. Infrastruct. Eng.* 1–18. <https://doi.org/10.1080/15732479.2019.1676790>.
- Phoon, K.-K., 2014. *Risk and Reliability in Geotechnical Engineering*. CRC Press. <https://doi.org/10.1201/b17970>.
- Phoon, K., Nadim, F., Uzielli, M., Lacasse, S., 2006. Soil variability analysis for geotechnical practice, in: *Characterisation and Engineering Properties of Natural Soils*. Taylor & Francis. <https://doi.org/10.1201/NOE0415426916.ch3>.
- Phoon, K.K., Retief, J.V., Ching, J., Dithinde, M., Schweckendiek, T., Wang, Y., Zhang, L.M., 2016. Some observations on ISO2394:2015 Annex D (Reliability of Geotechnical Structures). *Struct. Saf.* 62, 24–33. <https://doi.org/10.1016/J.STRUSAFE.2016.05.003>.
- Rosenblueth, E., 1975. Point estimates for probability moments. *Proc. Natl. Acad. Sci. U.S.A.* 72, 3812–3814. <https://doi.org/10.1073/pnas.72.10.3812>.
- Rui, R., Han, J., Zhang, L., Zhai, Y., Cheng, Z., Chen, C., 2020. Simplified method for estimating vertical stress-settlement responses of piled embankments on soft soils. *Comput. Geotech.* 119, 103365. <https://doi.org/10.1016/j.compgeo.2019.103365>.
- Schanz, T., Vermeer, P.A., Bonnier, P.G., 1999. The hardening-soil model: Formulation and verification. In: *Brinkgreve, R.B.J. (Ed.), Beyond 2000 in Computational Geotechnics*. Balkema, Rotterdam, pp. 281–290.
- Suchomel, R., Mašín, D., 2011. Probabilistic analyses of a strip footing on horizontally stratified sandy deposit using advanced constitutive model. *Comput. Geotech.* 38, 363–374. <https://doi.org/10.1016/j.compgeo.2010.12.007>.
- Winkelmann, K., Górski, J., 2014. The use of response surface methodology for reliability estimation of composite engineering structures. *J. Theor. Appl. Mech.* 52, 1019. <https://doi.org/10.15632/jtam-pl.52.4.1019>.
- Wu, W., Bauer, E., Niemunis, A., Herle, I., 1993. Visco—Hypoplastic Models for Cohesive Soils, in: *Modern Approaches to Plasticity*. Elsevier, pp. 365–383. <https://doi.org/10.1016/B978-0-444-89970-5.50023-6>.
- Żółtowski, K., 2012. Road grade on bridge structures: selected problems during the construction of bridges in Poland. *6th Polish Conference of Bridge Engineers: Structure and Infrastructure of Bridges*. Wiśła, 275–281.