



© 2023. The Author(s). This is an open-access article distributed under the terms of the Creative Commons Attribution-ShareAlike 4.0 International Public License (CC BY SA 4.0, <https://creativecommons.org/licenses/by-sa/4.0/legalcode>), which permits use, distribution, and reproduction in any medium, provided that the article is properly cited, the use is non-commercial, and no modifications or adaptations are made

Process control of air stream deodorization from vapors of VOCs using a gas sensor matrix conducted in the biotrickling filter (BTF)

Dominik Dobrzyniewski*, Bartosz Szulczyński, Piotr Rybarczyk, Jacek Gębicki

Department of Process Engineering and Chemical Technology,
Faculty of Chemistry, Gdańsk University of Technology, Gdańsk, Poland

*Corresponding author's e-mail: (domdobrz@student.pg.edu.pl)

Keywords: biofiltration, electronic nose, biotrickling filter, chemical sensors, sensor matrix, odorous compounds

Abstract: This article presents the validity, advisability and purposefulness of using a gas sensor matrix to monitor air deodorization processes carried out in a peat-perlite-polyurethane foam-packed biotrickling filter. The aim of the conducted research was to control the effectiveness of air stream purification from vapors of hydrophobic compounds, i.e., n-hexane and cyclohexane. The effectiveness of hydrophobic n-hexane and cyclohexane removal from air was evaluated using gas chromatography as the reference method and a custom-built gas sensor matrix consisting of seven commercially available sensors. The influence of inlet loading (IL) of n-hexane and cyclohexane on the biotrickling filtration performance was investigated. The prepared sensor matrix was calibrated with use of two statistical techniques: Multiple Linear Regression (MLR) and Principal Component Regression (PCR). The developed mathematical models allowed us to correlate the multidimensional signal from the sensor array with the concentration of the removed substances. The results based on gas chromatography analyses indicated that the elimination efficiencies of n-hexane and cyclohexane reached about 40 and 30 g m⁻³ h⁻¹, respectively. The results obtained using a gas sensor matrix revealed that it was possible not only to determine concentration reliably of investigated hydrophobic volatile organic compounds in the gas samples, but also to obtain results of a similar high level of quality as the chromatographic ones. A gas-sensor matrix proposed in this work can be used for on-line real-time monitoring of biofiltration process performance of air polluted with n-hexane and cyclohexane.

Introduction

Among the gaseous air pollutants, the so-called odorants (odorous substances) are of special importance. These compounds are characterized by odor nuisance. They deteriorate the quality of life of citizens inhabiting the areas adjacent to emission sources (Zhang et al. 2021). Odor-generating substances are volatile components of air having toxic properties, being detectable at relatively low concentrations and causing undesirable odor sensations (Cheng et al. 2019). This group includes volatile organic compounds (VOCs) and volatile inorganic compounds (VICs) (Zhang et al. 2010). Selection of the appropriate solid waste management methods (Pawnuke et al. 2022) or waste gas treatment technology is a complex process. Chemical composition and physical properties of a given gas stream, including gas flow rate, temperature, humidity, solubility and concentration of pollutants have to be taken into account (Schlegelmilch et al. 2005).

Biological methods are commonly and widely used for the removal of contaminants and gas deodorization (Rybarczyk 2022). These methods use microorganisms to oxidize both

volatile organic compounds (including odorants) and inorganic substances, mainly hydrogen sulfide and ammonia. This is possible thanks to heterotrophic microorganisms, which use the energy of chemical bonds of the absorbed organic compounds to sustain life processes, and autotrophs which, for the same purpose, convert the energy of such reactions as nitrification or decomposition of hydrogen sulfide to elemental sulfur (Wysocka et al. 2019).

The microbes used in biofiltration processes are characterized by good adaptability, therefore these processes can be applied to the purification of gas streams of diverse composition. However, certain limitations must be borne in mind. The removed pollutants must be biodegradable, occur in low concentrations, cannot be toxic for microorganisms and should be soluble in water (Schlegelmilch et al. 2005). Degradation of hydrophobic contaminants is also possible, but poses considerable problems, mainly due to mass transfer barrier from gas to liquid phase. However, biotrickling filtration of hydrophobic VOCs may be enhanced. This may be achieved, e.g., by modification of liquid phase by adding organic solvents (two-phase bioreactors) or surfactants, use of fungi, dedicated microbial consortia or novel packing materials,

introducing gas pre-treatment with, e.g., UV radiation as well as by mixing hydrophobic VOCs with hydrophilic ones (Miller et al. 2020, Rybarczyk et al. 2021, Cheng et al. 2016b, Wu et al. 2022). Compared to other deodorization methods, during biofiltration the pollutants are not only removed from the gas, but also inactivated and neutralized during biodegradation by microbes. As a result of biofiltration, no burdensome secondary wastes are generated (Chen et al. 2016).

Biofiltration processes as well as other deodorization methods should be monitored and controlled continuously. Various measurement techniques are used for this purpose, allowing for both quantitative and qualitative analysis of gas composition. Instrumental techniques are most commonly used with special regard to gas chromatography coupled with mass spectrometry (GC-MS) or flame ionization detector (GC-FID) (Giungato et al. 2018, Buliner et al. 2012). In recent years, a rapidly developing analytical technique, Multidimensional Gas Chromatography-Mass Spectrometry (MDGC-MS), has emerged to achieve even lower detection limits (Giungato et al. 2018).

On the other hand, methods using matrices of non-selective gas sensors (so-called electronic noses) are becoming more and more popular. The research conducted in this area is quite intensive as the possibility of using these devices for continuous monitoring of odor quality has been observed (Munoz et al. 2010). Electronic noses belong to the group of analytical (instrumental) techniques included in the methods of odor quality analysis. Multidimensional signal from the

matrix needs to be statistically analyzed. Principal Component Analysis (PCA) is often used for this purpose, but Multiple Linear Regression (MLR), Principal Component Regression (PCR) or Partial Least Squares Regression (PLSR) are also used however a little less frequently. The most complicated method of identifying the smell of gas mixture is the use of Artificial Neural Network – ANN (Sabilla et al. 2017, Brattoli et al. 2011).

Contrary to chromatographic methods, electronic noses are much cheaper and allow for shorter analysis time. Thanks to easily replaceable modules, electronic noses may be adapted to different types of application. Table 1 shows the latest application of electronic noses and gas sensor array to control biofiltration gas treatment processes.

This paper presents the use of a gas sensor array to assess the effectiveness of the biotrickling filtration of air polluted with *n*-hexane and cyclohexane. These two compounds were selected due to their co-existence in atmospheric air in the vicinity of potential sources of odor emissions such as Municipal Solid Waste Treatment Plant, Municipal Landfills or Wastewater Treatment Plants (Fang et al. 2012, Zarra et al. 2014). Moreover, both are characterized by low olfactory thresholds (Nagata et al. 2003), which makes them easily perceptible to the human sense of smell and subsequently contributing significantly to the odor nuisance in a given area. The main objective of this study was to demonstrate the feasibility of sensor matrices as an alternative method for monitoring the efficiency of the biofiltration of VOCs mixture

Table 1. Applications of electronic noses for monitoring of biofiltration processes

Type of biofilter	Compounds removed	Data analysis	Process Control	Ref.
BTF	<i>n</i> -hexane acetone toluene	MLR	Electronic nose prototype with eight MOS sensors	(Szulczyński et al. 2018a)
BTF	VOCs	PCA PLSR	Pen3 e-nose (Airsense Analytics GmbH, Germany) with an array of 10 different MOS sensors	(Lopez et al. 2001)
BTF	cyclohexane	MLR	E-nose prototype with eight MOS sensors manufactured by Figaro Engineering Inc. (Mino, Osaka, Japan)	(Rybarczyk et al. 2019)
BF	VOCs	PCA PLSR ANN	E-nose (AromaScan A32S, Crewe, UK) with an array of 32 conducting polymer sensors	(Sohn et al. 2009)
BTF	<i>n</i> -butanol	MLR PCR PLSR	The e-nose prototype with eight TGS MOS sensors manufactured by Figaro Inc.	(Szulczyński et al. 2018b)
BTF	α -piene	PCA	Pen3 e-nose (Airsense Analytics GmbH, Germany) with an array of 10 different MOS sensors and portable VOCs analyzer (MULTIRAE IR, PGM-54, USA)	(Cabeza et al. 2013)
BTF	hexane ethanol	MLR	The prototype of an e-nose with eight sensors: Mini PID, 2 electrochemical sensors and 5 MOS sensors	(Rybarczyk et al. 2020)
BF	VOCs Ammonia H ₂ S	N/A	Portable multi-Gas detector MultiRAE (RAE System Inc., San Jose, CA) with electrochemical, catalytic, infrared and photoionization (PID) sensors	(Rolewicz-Kalińska et al. 2021)
BTF	<i>n</i> -butanol	ANN	The e-nose prototype with eight chemical sensors: ION Science Mini PID and TGS MOS sensors manufactured by Figaro Inc.	(Szulczyński et al. 2019)
BF	VOCs	PCA	Portable E-nose PEN3.5 (Win Muster Airsense Analytics Inc., Schwerin, Germany) with 10 different MOS sensors	(Liang et al. 2020)

using gas chromatography as a reference. The self-constructed matrix consisted of seven commercially available gas sensors, and two statistical techniques were used to calibrate it, which were Multiple Linear Regression (MLR) and Principal Component Regression (PCR).

In this work, the matrix was calibrated and validated in relation to the chemical concentrations of individual compounds expressed in parts per million (ppm). The results obtained with the sensor array were compared with those obtained using gas chromatography with flame-ionization detector (GC-FID), trying to show that the results can be of a similar quality. Although gas sensor arrays are not yet widely used for monitoring deodorization processes, they show high application potential. Moreover, unlike gas chromatography, it is possible to use them for continuous monitoring of main odor features such as: odor concentration, hedonic tone and odor intensity. This requires the use of multidimensional statistical analysis and machine learning methods as well as sensory analysis (e.g. field olfactometry) in order to determine the odor interactions occurring in multicomponent odor mixtures of chemical compounds (Maurer et al. 2018). However, combination of all these elements and their simultaneous analysis using one device would save significant time and funds.

Theoretical

Both Multiple Linear Regression (MLR) and Principal Component Regression (PCR) are statistical mathematical methods that allow for the determination of a linear relationship between the independent variables (sensor signals) and the dependent variable (chemical compound concentration). In the case of MLR, direct regression of the explanatory variables to the dependent variable is used, assuming that there is a linear relationship at all, independent variables are not correlated with each other and the variance of the residuals is constant and independent. The general formula for MLR is represented by Eq. (1):

$$y_i = \alpha_0 + \alpha_1 S_1 + \alpha_2 S_2 + \dots + \alpha_i S_i \quad (1)$$

where y_i is the predicted variable, α_i regression coefficients, S_i explanatory variables, i number of independent variables, and α_0 the intercept. The PCR technique is used for the same purpose, but for regression analysis it uses the so-called Principal Components (PC_i) in place of the original attributions. This requires a multivariate reduction technique in the form of Principal Component Analysis (PCA), but it allows for the disentangling of the dataset and the elimination of variables with low impact on model improvement. Then in the next step, after creating the disparate variable matrix, the MLR model is fitted with the PC_i as predictor variables. The dependent variable is computed in accordance with Eq. (2):

$$y_i = \beta_0 + \beta_1 PC_1 + \beta_2 PC_2 + \dots + \beta_i PC_i \quad (2)$$

where y_i is the predicted variable, β_i regression coefficients, PC_i principal components, i number of principal components, and β_0 the intercept. As can be deduced, the main idea of PCR is to reduce the multidimensionality of the dataset, which decreases

the chances of model overfitting, which is a common problem when using MLR. This is due to the fact that the coefficient of determination (R^2), which informs how the dependent variable can be explained by the variation of independent variables increases as the number of predictors in the model is added. PCR reduces the number of predictors by assuming that fewer PC_i represent most of the variability in the data set.

It should be noted that MLR and PCR are conventional statistical techniques whose main limitations are related to the assumptions of linearity, normality, independence of variables, single-pass approximation or dimensionality. If the considered data set meets these assumptions, there is no need to use more complex techniques. Another approach would require the use of machine learning including artificial neural networks (ANN), which may also be successfully used for prediction problems but are much more complicated.

Experimental

Biofiltration unit

The gas mixture generation system consisted of two vials filled with the investigated chemical substances in a liquid form through which dried and purified air was passed with a constant flow rate controlled by mass flow controllers (MFC). As a result of bubbling, air bubbles are saturated with VOCs vapors. The concentration and flow of the gas mixture was controlled and regulated using MFC (Figure 1). Gaseous samples were taken at the inlet and the outlet of the BTF using TEDLAR foil bags and then immediately analyzed with the GC-FID and the gas sensor array.

The investigations were carried out in a biotrickling filter fabricated as a single-section Plexiglas column with an inner diameter (d_i) of 0.08 m. The biofilter was packed with round discs of polyurethane foam (Murano Feniks, Wejherowo, Poland, PPI: 10, porosity: 97%, bulk density: 25 kg m⁻³) and the total height of the packing (h) was equal to 0.68 m. The polyurethane discs were inoculated with peat-derived microorganisms during previously conducted biotrickling filtration process. In the mentioned process, a biotrickling filter was packed with alternate layers (sandwich-type) of a polyurethane foam discs and a commercially available mixture of peat and perlite (Compo Sana, Compo GmbH, Munster, Germany, porosity of dry material: 90%, porosity of wet material: 25–30%, bulk density 176 kg m⁻³) with ceramic Raschig rings (BROWIN, Łódź, Poland, porosity: 58%, bulk density: 946 kg m⁻³, material density: 2250 kg m⁻³).

Such inoculum and packing materials were chosen for two main reasons. Firstly, peat is a well-established biological material to serve as a source of various microorganisms useful in biofiltration processes (Arnold et al. 1997, Chou and Shiu 2011). Secondly, the proposed mode of polyurethane foam inoculation may be of practical application in the future, offering acceptable pressure drop during the inoculation phase (mixed packing with peat, perlite, ceramic rings and polyurethane foam discs) and stable process performance after removing the peat/perlite fraction.

The biofilter bed was trickled periodically using a mineral salt medium consisting of Na₂HPO₄·2H₂O, KH₂PO₄, NaCl and NH₄Cl. Volumetric flow rate of trickling liquid (V_l) was 0.2 dm³ min⁻¹ and the trickling frequency (t_f) was 0.5 min h⁻¹.

Total volume of the biotrickling filter packing (V) was equal to 2.5 dm³. The effectiveness of the conducted air biofiltration deodorization was evaluated by calculating the values of removal efficiency (RE) and elimination capacity (EC) according to the relationship presented by Eq. (3) and (4). In addition, the effect of IL on gas stream purification efficiency was analyzed while keeping the empty bed resistance time ($EBRT$) constant.

$$RE = \frac{C_{in} - C_{out}}{C_{in}} \cdot 100\% \quad [\%] \quad (3)$$

where C_{in} is the concentration of the chemical substance in the inlet stream expressed in ppm, C_{out} is the concentration of the chemical substance in the outlet stream expressed in ppm, and Q is a volumetric gas flow rate amounting to 2.5 dm³ min⁻¹.

$$EC = \frac{Q \cdot (C_{in} - C_{out})}{V} \quad [gm^{-3}h^{-1}] \quad (4)$$

$$IL = \frac{Q \cdot C_{in}}{V} \quad [gm^{-3}h^{-1}] \quad (5)$$

$$EBRT = \frac{V}{Q} \quad [min] \quad (6)$$

GC-FID analysis

Gas chromatography coupled with a flame-ionization detector (Varian CP-3800, Varian Analytical Instruments, USA) was used as a reference method in this study. The concentration of *n*-hexane and cyclohexane in gaseous samples was determined using a DB-624 column (Agilent Technologies, USA) and nitrogen as a carrier gas (3.5 ml min⁻¹). The other

parameters were as follows: injector temperature – 130°C, Oven temperature – 150°C, detector temperature – 250°C, split ratio – 10, and inject volume – 0.5 ml.

Electronic nose measurement

Gas sensors array development

The constructed gas sensor array consisted of seven commercially available gas sensors. Five of them were TGS Metal Oxide Semiconductor (MOS) sensors produced by Figaro Engineering Inc. (Mino, Osaka, Japan): TGS2600 (air contaminants), TGS2602 (VOCs and odorous gases), TGS2603 (air contaminants), TGS823 (organic solvents vaporous) and TGS8100 (air contaminants). Moreover, one photo-ionization detector (PID-A12 for VOCs with ionization potentials <10.6 eV) manufactured by Alphasense Metek (Great Notley, Braintree, United Kingdom) and a temperature and humidity sensor were placed in the measurement chamber because these parameters were expected to change significantly between the inlet and outlet streams, which undoubtedly affected the signals received from the matrix. All of the sensors are capable of detecting a wide range of volatile chemicals and have been selected so that their detection ranges correspond to the concentrations expected during the research. Sensors were placed in the separate gauge cell in order to provide an individual working environment for each of them. The sensor chambers were made of materials that do not adsorb pollutants (Polytetrafluoroethylene – PTFE) in order to avoid disturbances in consecutive measurements. Figure 2 presents the system used for the sensor analysis of collected gas samples.

Prior to analysis of each sample, the system was flushed with purified air from zero air generator (LAT LTD, Katowice, Poland) which caused the signals from the sensors to return to their initial values (sensors baseline). The three-way valve made it possible to switch between the reference track and the measurement track through which the analyzed sample was sucked into the sensor's

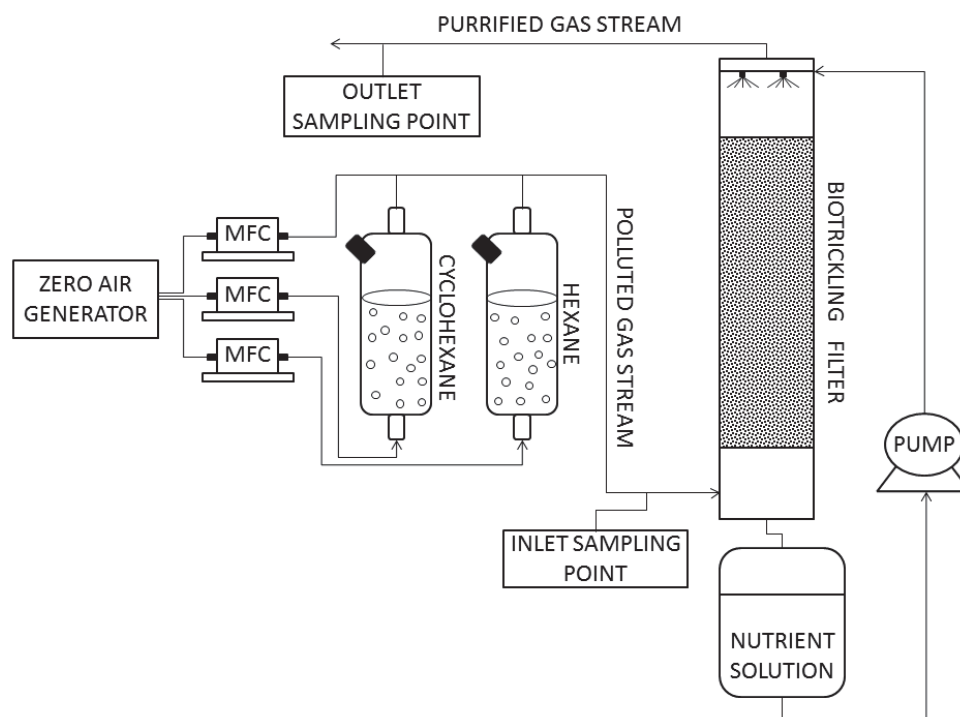

Fig. 1. Scheme of a biofiltration unit

chamber by a diaphragm pump (DP 0102-X1-0001, Nitto Kohki CO., LTD. Tokyo, Japan) with a constant flow rate (50 ml/min). All electronic connections have been made in accordance with the manufacturer's recommendations and relevant product data sheets. Analog sensor signals were converted from a continuous form to the analytically useful discrete form using an analog-to-digital converter and saved on the computer. The voltage supplying the pump was controlled by pulse-width modulation module (PWM), which allows for the control of the rotational speed of the engine while clearly translating the samples flow rate through the system. This method of controlling the flow rate allowed for the application of the gas sensor array in the stop-flow mode. The sample flow time through the system was 60 seconds and the stoppage time in the sensor's chamber was 40 seconds. The times of individual stages selected in this way ensured that all of the sensors used would achieve a steady (stable) state.

Data analysis and calculations

In the case of MOS sensors, the presence of reducing gases increases the conductivity of the active layer (metal oxide) and the value on the transducer corresponds to voltage on the resistive divider formed by the precision thin film resistors. In such system, the relationship between the sensor signal and the concentration of a substance is presented by Eq. (7).

$$S_i = U \cdot \frac{R_l}{R_l + R_s} \quad (7)$$

where S_i is sensor signal, U supply voltage, R_l reference resistance, and R_s sensor resistance. The reference resistances are constant values for a given sensor and have been selected in such a way as to ensure the correct operation of the sensors

within a wide detection range. For PID sensor, the voltage dependence on gas concentration is linear, but the directional coefficient is strongly dependent on the type of gas. This means that it needs to be calibrated for each practical application.

Data analysis and other calculations were accomplished using RStudio desktop (v.1.0.143) software. To perform mathematical operations, the signals from the installed sensors in the form of voltage values on the ADC converter were used. In the conducted research, two approaches were used to extract the signals from the sensor array. The first was to calculate the difference between the sensor baseline and the maximum signal value for a given analysis – ΔS_i (Eq. 8). Whereas the second reflected the relative signal values from the individual sensors – $S_{r,i}$ (Eq. 9).

$$\Delta S_i = S_{max,i} - S_{0,i} \quad (8)$$

$$S_{r,i} = \frac{S_{max,i}}{S_{0,i}} \quad (9)$$

where $S_{max,i}$ is the maximum value of the signal in a given analysis after reaching steady state, and $S_{0,i}$ is sensor baseline determined for synthetic (zero) air. Based on the data set prepared in this way, the developed gas sensor matrix was calibrated using statistical models, which were Multiple Linear Regression (MLR) and Principal Component Regression (PCR). Gas calibration mixtures were prepared using the mixture generator system shown in Figure 1 after minor modifications. The vial of pure water was added to account for the effect of humidity on the gas sensor array signals. The modified gas mixture generator is shown in Figure 3. Validation of the prepared mathematical models was performed on real samples from the biofiltration air deodorization process.

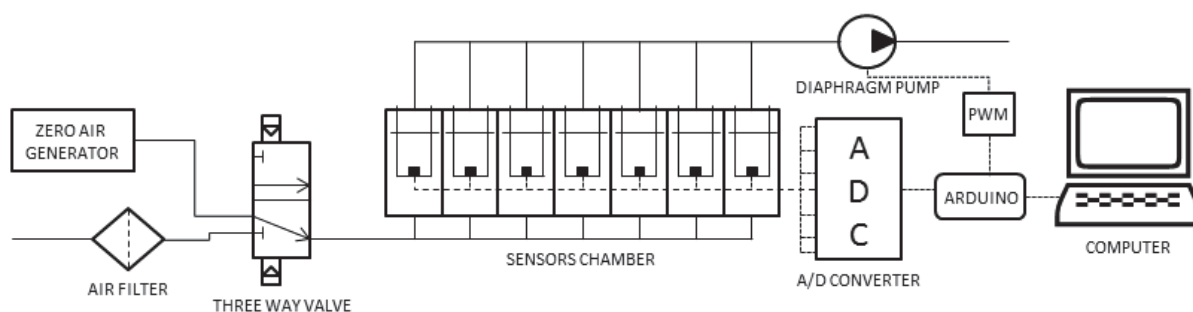

Fig. 2. Diagram of a system used for the gas sensor array measurements

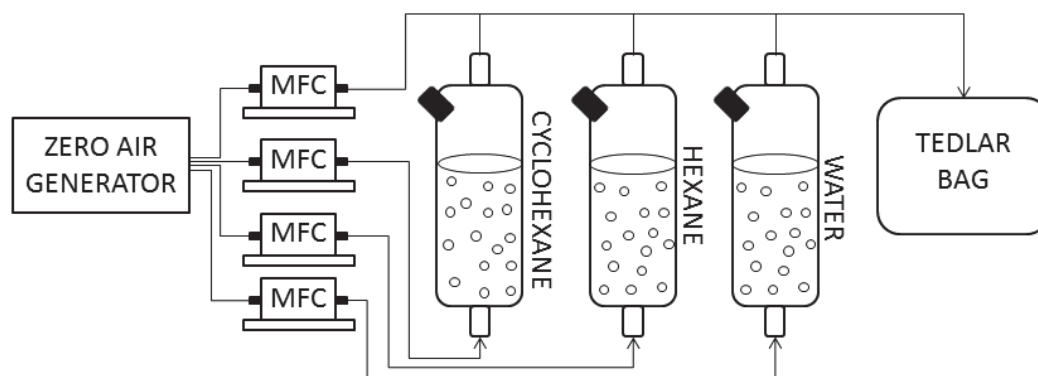

Fig. 3. Diagram of the gas calibration mixtures generator

Results and discussion

In the first phase of the study, the developed gas sensor array had to be calibrated. For this purpose, the prepared gas mixtures were used, in which the concentration of *n*-hexane and cyclohexane ranged from 50 to 500 ppm. The quantitative analysis to determine the concentrations in individual mixtures was performed with the use of GC-FID and then they were correlated with the signals from the sensor matrix using MLR and PCR. The analysis of each sample was repeated three times. The equations of the obtained models along with the determination coefficients are outlined in Table 2. As can be seen, not all signals from the sensors were statistically important in the developed models. The models were iterated on the basis of the *t*-test (test statistic) which allowed us to reduce the probability that the obtained results were incidental.

In the case of the MLR model for cyclohexane, the signals from the TGS2602 and TGS2603 sensors in the form proposed by Eq. (8) and Eq. (9) turned out to be completely insignificant. A similar situation occurred for *n*-hexane, but this time the

TGS823 sensor was completely excluded from the developed MLR model. Additionally, it is worth noting that temperature and humidity were statistically significant elements of each of the prepared models.

Figure 4 presents calibration plots showing the relationship between the reference results obtained by the gas chromatography method and the predicted concentration values of individual substances calculated on the basis of the prepared models. For both substances, the PCR models are characterized by a smaller scatter of the predicted concentrations as compared to the chromatographic results, which is reflected by their higher coefficients of determination.

In the next step, the prepared models were validated by testing them on real samples from the air stream deodorization process conducted in a biotrickling filter. Figure 5 shows the influence of inlet loading (*IL*) on the air purification efficiency of cyclohexane and *n*-hexane vapors. The process was divided into three stages, each lasting ten days and characterized by a different *IL* while maintaining a constant empty bed residence time (*EBRT*) of sixty seconds. This figure also presents the

Table 2. Equations of the obtained models

Chemical Compound	Model	Equation	R ²
Cyclohexane	MLR	$C = -264.42 - 416.75 \cdot \Delta S_1 + 195.61 \cdot \Delta S_4 + 0.09 \cdot S_{r1} - 0.58 \cdot S_{r4} + 8.16 \cdot S_{r5} + 106.71 \cdot S_{r6} + 3.30 \cdot T + 2.14 \cdot RH$	0.963
	PCR	$C = -124.87 + 1.59 \cdot PC_1 + 11.12 \cdot PC_2 - 11.59 \cdot PC_3 - 20.72 \cdot PC_4 = 7.37 \cdot PC_5 - 2.64 \cdot PC_6 - 36.99 \cdot PC_7$	0.989
<i>n</i> -hexane	MLR	$C = 217.85 - 201.52 \cdot \Delta S_1 - 828.16 \cdot \Delta S_2 + 224.71 \cdot \Delta S_3 + 138.79 \cdot \Delta S_5 + 129.05 \cdot \Delta S_6 + 16.44 \cdot \Delta S_{r2} - 560.12 \cdot S_{r6} - 4.63 \cdot T + 6.47 \cdot RH$	0.932
	PCR	$C = 145.63 + 39.01 \cdot PC_1 + 10.91 \cdot PC_2 - 19.356 \cdot PC_3 - 7.33 \cdot PC_4 - 43.95 \cdot PC_5 + 20.41 \cdot PC_6 + 27.84 \cdot PC_7$	0.990

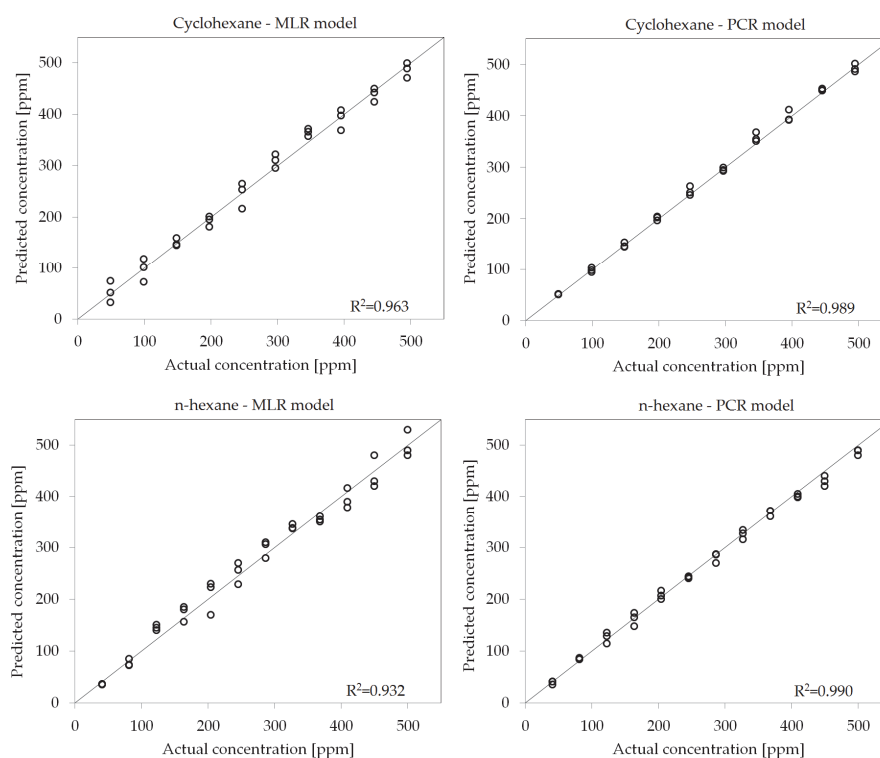

Fig. 4. Gas sensor array calibration scatter plots

effectiveness of deodorization controlled by a gas sensor array and calculated on the basis of the proposed models.

For the first ten days of the process (stage I) the *IL* for *n*-hexane ranged from 19.87 to 24.36 g m⁻³ h⁻¹ and then the highest removal efficiency was achieved for this substance which fluctuated between about 70–80%. In stage 2 and stage 3, there were increases in *IL* to values ranging from 53.12–58.12 g m⁻³ h⁻¹ and 82.11–87.34 g m⁻³ h⁻¹, respectively. The periods of increases in *IL* corresponded to a decrease in the efficiency of removing *n*-hexane from the air stream. In the second stage, the highest *RE* value achieved was 59% and the lowest was equal to 51% while in the third stage these values were 41% and 29%, respectively. These corresponded to maximum *EC* value for *n*-hexane of about 40 g m⁻³ h⁻¹. Similar relationships can be observed for the efficiency of air deodorization from cyclohexane vapors. In stage one, where the *IL* was the lowest (13.20–18.50 g m⁻³ h⁻¹) the highest *RE* (61–71%) has been achieved. The second stage with the highest *IL* values (57.42–63.19 g m⁻³ h⁻¹) corresponded to the lowest deodorization efficiency. When moving from stage II to stage III, the *RE* initially returned to the value of stage one, but higher *IL* values (28.74–36.48 g m⁻³ h⁻¹) meant that after two days the *RE* stabilized at level of 42–51%. The highest *EC* value for cyclohexane was about 30 g m⁻³ h⁻¹. Resembling patterns of decline in biofilter performance due to *IL* manipulation have already been observed in the literature (Yang et al. 2010, Vergara-Fernandez et al. 2018). The decrease in *RE* due to the increase in *IL* may be the result of a high input load of the VOC

mixture. On the other hand, high *IL* can cause rapid biomass growth and lead to bed clogging and drainage phenomena, causing the biofilter performance to deteriorate.

It is worth noting that *EC* values for cyclohexane and *n*-hexane obtained in this work are similar to the results obtained in other studies. Elimination capacities for *n*-hexane when treated solely in biotrickling filters were noted in the range between about 12 to 45 g m⁻³ h⁻¹, depending of the process condition (Cheng et al. 2016a, Yu et al. 2021). Salamanca et al. reported elimination capacity of cyclohexane of about 38 g m⁻³ h⁻¹ (Salamanca et al. 2017). In this work, these two VOCs were treated simultaneously and the differences between process performances are mainly due to different packing materials, the use of fungi, the use of peat as a source of inoculum as well as applied process parameters, especially gas flow rate and trickling pattern.

The validity and desirability of using a gas sensor array to monitor the biofiltration process were confirmed during the conducted research. The results obtained in this way are comparable to the reference chromatographic outcomes (Figure 5). However, the selection of the optimal calibration model for the matrix from the point of view of the test performed remained a controversial issue. One of mathematical tools used to estimate model errors in predicting quantitative data and to assess its fit is to determine the Root Mean Square Error (RMSE). In data science, RMSE is treated as the normalized distance between vectors of predicted and actual values and is used as a standard statistical tool to serve as heuristics for

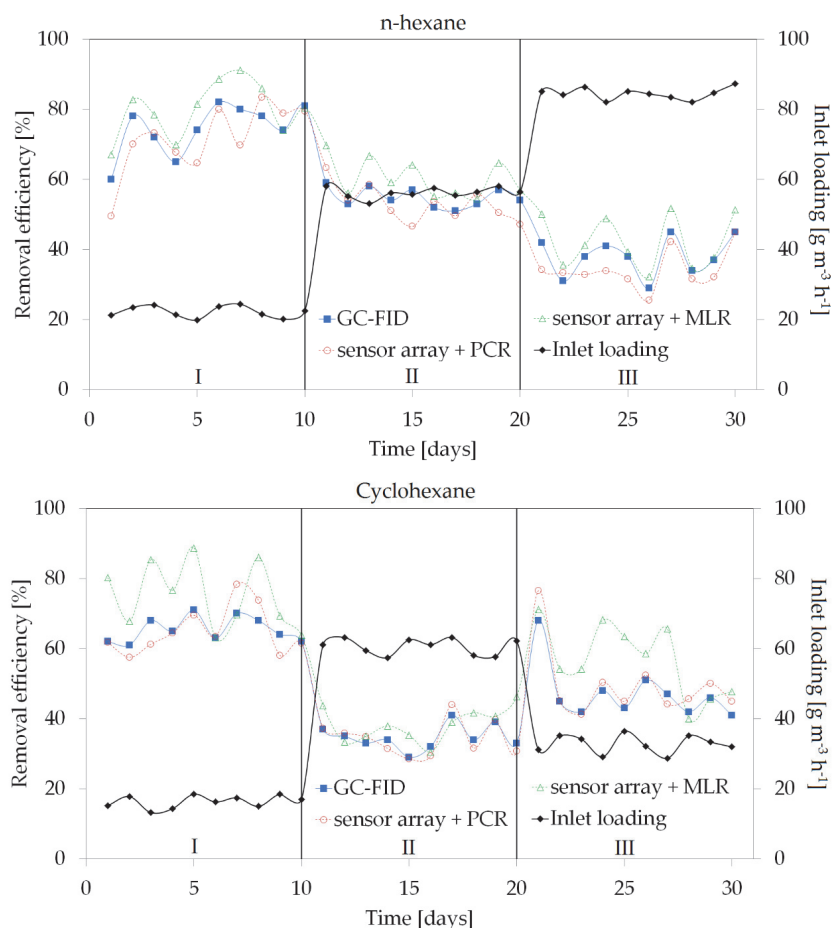

Fig. 5. Influence of *IL* on the biofiltration efficiency for removing VOCs from the air stream

training models and evaluating the usefulness and accuracy of the trained models. Theoretically, the lower the RMSE value, the better the models fit. However, it should be remembered that this is a relative concept and the specific application of the model, that is why, the unit in which RMSE is expressed and the phenomenon of overfitting must be taken into account when making an assessment. Table 3 shows the calculated RMSE values for the developed models, both at individual stages of the process and for its entire duration.

PCR model for cyclohexane has a better fit to the reference chromatographic results than the MLR. At individual stages of the process, the differences in the resulting RMSE are also large enough to conclude that the MLR overestimated the predicted values. In the case of models created for *n*-hexane, the RMSE values for the entire process are very similar and differ by only half a percentage point. Both models return predicted variables at a level of quality scaled to the chromatographic results, and as shown in Figure 5, MLR tends to indicate values higher than the chromatographic ones almost throughout the entire duration of the process. Additionally, it should be noted that all the developed models are characterized by the lowest RMSE values in the process stages where the *IL* reached the highest ranges for a given substance (stage II for cyclohexane and stage III for *n*-hexane). In contrast, the largest RMSE values, which theoretically means the worst accuracy of the models, corresponded to the stages with the lowest *IL*. Assuming a constant volume of BTF packing and volumetric gas flow rate, and bearing in mind that, in the case of the conducted tests, higher *IL* values correspond simultaneously with higher values of inlet concentrations of the analyzed substances and with the lowest RE values (the highest concentrations at the outlet of the BTF) it would mean that the developed models represent greater accuracy with increasing concentration of the analyzed substances. The fact that the developed models function in such a way could be due to the fact that at low concentrations the sensors work near the limit of quantification, and at higher concentrations in the linear range of operation, i.e., the obtained results, and thus the prepared models are more accurate.

Conclusions

The obtained results indicate that the highest removal efficiency of *n*-hexane and cyclohexane from air was achieved in conditions set for the lowest of the tested *IL* values and for the empty bed resistance time (EBRT) of 60 seconds. In the case of *n*-hexane, this RE fluctuated between 70–80% with *IL* ranging from 19.87 to 24.36 g m⁻³ h⁻¹, while for cyclohexane, the highest RE varied between 61–71% for *IL* betwixt 13.20–18.50 g m⁻³ h⁻¹. Each increase in *IL*, while keeping the EBRT at a constant level, resulted in a decrease in the biofilter

removal efficiency. Based on physicochemical and toxicity parameters of *n*-hexane and cyclohexane, the second one should be more easily eliminated from the gas stream than *n*-hexane. It is because cyclohexane has lower molecular mass, is less toxic (e.g. value of LD₅₀ is 2 orders of magnitude higher than for *n*-hexane), is not regarded to undergo bioaccumulation, and has two orders of magnitude higher solubility in water, thus should more easily diffuse in the biofilm phase. However, in the experimental conditions there were different inlet loadings with respect to *n*-hexane and cyclohexane. From Fig. 5 it stands out that the concentrations of *n*-hexane were in all stages of experiment higher than for cyclohexane, thus *n*-hexane was a more abundant carbon source for microorganisms, and its removal can be higher than for cyclohexane. Similar behavior of the elimination capacities for different VOCs was noted by Marycz et al. 2022.

The applied matrix of gas sensors together with developed statistical mathematical models (MLR and PCR) allowed us to obtain results with a high degree of compatibility with the chromatographic ones. Linear calibration correlations showing the relationships between the actual concentrations of the analyzed substances and those predicted by the models were characterized by high compliance (all coefficients of determination R² > 0.93). In order to estimate the errors of the models in predicting quantitative data and evaluate their fit, root mean square error (RMSE) was used as one of the most frequently applied mathematical tools for this purpose. The MLR and PCR models prepared for *n*-hexane represented a very similar value of this coefficient (5.954% and 5.494%, respectively), therefore the selection of the optimal model was complicated. In contrast, for cyclohexane, the PCR model with the RMSE of 3.542% was found to be significantly better than the MLR model with the RMSE equal to 10.597%.

The results presented in this paper justify the use of gas sensor arrays for monitoring biofiltration processes. This type of device would enable the process to be controlled automatically, continuously and without taking any samples. On the other hand, the tests were run in laboratory conditions, and only a simple two-component mixture was analyzed. For example, landfill gases are generally more complex mixtures in which numerous odor-forming substances may be present. In this case, the continuous determination of the chemical concentration of individual substances would not be the optimal approach. It is caused by mutual interactions between odorants (masking, neutralization, strengthening), which significantly influence the perceived odor nuisance. This could lead to situations when the complete elimination of one of the components may increase the odor nuisance. This phenomena cannot be captured by chromatographic techniques that determine concentrations of chemicals. However, the use of gas sensor matrices makes it

Table 3. RMSE of deodorization efficiency (RE) between GC-FID and sensor matrix results.

Chemical compound	Model	RMSE [%]			
		Stage I	Stage II	Stage III	Entire process
<i>n</i> -hexane	MLR	6.524	6.206	5.028	5.954
	PCR	6.587	4.885	4.827	5.494
cyclohexane	MLR	12.363	5.950	12.192	10.597
	PCR	4.477	1.944	3.717	3.542

possible in this case to switch to the analysis of odor parameters such as: odor intensity, odor concentration or hedonic quality. This would require calibrating the matrix using, for example, field olfactometry or parametric measurements, but it seems to be a better approach to monitor the effectiveness of deodorization processes and assessment of odor impact (Wiśniewska et al. 2020). It would allow for the monitoring of the odorous situation of a given facility, not the concentrations of individual substances, which do not always reflect the actual odor nuisance.

Acknowledgements

The investigations were financially supported by the Grant “Determination of the mechanism of improved biofiltration efficiency of air contaminated with hydrophobic compound vapors as a result of the addition of hydrophilic compound vapors”, No. UMO-2019/35/N/ST8/04314 from the National Science Centre, Poland.

The article was partially presented during the XIIth Scientific Conference Air Protection in Theory and Practice, Zakopane, Poland, October 18–21, 2022.

Conflicts of Interest

On behalf of all authors, the corresponding author states that there is no conflict of interest.

References

- Arnold, M., Reittu, A., von Wright, A., Martikainen, P.J. & Suihko, M-L. (1997). Bacterial degradation of styrene in waste gases using a peat filter. *Applied Microbiology and Biotechnology*, 48, pp.738–744. DOI:10.1007/s002530051126
- Brattoli, M., De Gannero, G., De Pinto, V., Loiotile, A.D., Lovascio, S. & Penza, M. (2011). Odour detection methods: olfactometry and chemical sensors. *Sensors*, 11, 5, pp. 5290–5322. DOI:10.3390/s110505290
- Buliner, E.A., Koziel, J.A., Cai, L. & Wright, D. (2012). Characterization of livestock odors using steel plates solid-phase microextraction, and multidimensional gas chromatography-mass spectrometry-olfactometry. *Journal of the Air & Waste Management Association*, 56, 10, pp. 1391–1403. DOI: 10.1080/10473289.2006.10464547
- Cabeza, I.O., Lopez, R., Giraldez, I., Stuetz, R.M. & Diaz, M.J. (2013). Biofiltration of α -piene vapours using municipal solid waste (MSW) – Pruning residues (P) composts as packing materials. *Chemical Engineering Journal*, 233, pp. 149–158. DOI: 10.1016/j.cej.2013.08.032
- Chen, Y., Wang, X., He, S., Zhu, S. & Shen, S. (2016). The performance of a two-layer biotrickling filter filled with new mixed packing materials for the removal of from air. *Journal of Environmental Management*, 165, 1, pp. 11–16. DOI: 10.1016/j.jenvman.2015.09.008
- Cheng, Y., He, H., Yang, C., Yan, Z., Zeng, G. & Qian, H. (2016a). Effects of anionic surfactant on n-hexane removal in biofilters. *Chemosphere*, 150, pp. 248–253. DOI: 10.1016/j.chemosphere.2016.02.027
- Cheng, Y., He, H., Yang, C., Zeng, G., Li, X., Chen, H. & Yu, G. (2016b). Challenges and solutions for biofiltration of hydrophobic volatile organic compounds. *Biotechnology Advances*, 34, 6, pp. 1091–1102. DOI: 10.1016/j.biotechadv.2016.06.007
- Cheng, Z., Sun, Z., Zhu, S., Lou, Z., Zhu, N. & Feng, L. (2019). The identification and health risk assessment of odor emissions

from waste landfilling and composting. *Science of The Total Environment*, 649, pp. 1038–1044. DOI: 10.1016/j.scitotenv.2018.08.230

- Chou, M-S. & Shiu, W-Z. (2011). Bioconversion of Methylamine in Biofilters. *Journal of the Air & Waste Management Association*, 47, 1, pp. 58–65. DOI: 10.1080/10473289.1997.10464408
- Fang, J-J., Yang, N., Cen, D-Y., Shao, L-M. & He, P-J. (2012). Odor compounds from different sources of landfill: Characterization and source identification. *Waste Management*, 32, 7, pp. 1401–1410. DOI: 10.1016/j.wasman.2012.02.013
- Giungato, P., Gilo, A.D., Palmisani, J., Marzocca, A., Mazzone, A., Brattoli, M., Giua, R. & de Gennaro, G. (2018). Synergistic approaches for odor active compounds monitoring and identification: State of the art, integration, limits and potentialities of analytical and sensorial techniques. *Trends in Analytical Chemistry*, 107, pp. 116–129. DOI: 10.1016/j.trac.2018.07.019
- Liang, Z., Wang, J., Zhang, Y., Han, C., Ma, S., Chen, J., Li, G. & An, T. (2020). Removal of volatile organic compounds (VOCs) emitted from a textile dyeing wastewater treatment plant and the attenuation of respiratory health risks using a pilot-scale biofilter. *Journal of Cleaner Production*, 253, pp. 120019. DOI:10.1016/j.jclepro.2020.120019
- Lopez, R., Cabeza, I.O., Giraldez, I. & Diaz, M.J. (2011). Biofiltration of composting gases using different municipal solid waste-pruning residue composts: Monitoring by using an electronic nose. *Bioresource Technology*, 102, 17, pp. 7984–7993. DOI: 10.1016/j.biortech.2011.05.085
- Marycz, M., Rodriguez, Y., Gębicki, J. & Munoz, R. (2022). Systematic comparison of a biotrickling filter and a conventional filter for the removal of a mixture of hydrophobic VOCs by *Candida subhashii*. *Chemosphere*, 306, pp. 135608. DOI: 10.1016/j.chemosphere.2022.135608
- Maurer, D., Bragdon, A., Short, B., Ahn, H. & Koziel, J.A. (2018). Improving environmental odor measurements: Comparison of lab-based standard method and portable odor measurement technology. *Archives of Environmental Protection*, 44, 2, pp. 100–107. DOI: 10.24425/119699
- Miller, U., Sówka, I. & Adamiak, W. (2020). The use of surfactant from the Tween group in toluene biofiltration. *Archives of Environmental Protection*, 46, 2, pp. 53–57. DOI: 10.24425/aep.2020.133474
- Munoz, R., Sivert, E., Parsci, G., Lebrero, R., Wang, X., Suffet, I.H. & Stuetz, R.M. (2010). Monitoring techniques for odour abatement assessment. *Water Research*, 44, 18, pp. 5129–5149. DOI: 10.1016/j.watres.2010.06.013
- Nagata, E., Yoshio, Y. & Takeuchi, N. (2003). Measurement of Odor Threshold by Triangular Odor Bag Method. *Odor measurement review*, 118, pp. 118–127.
- Pawnuk, M., Szulczyński, B., den Boer, E. & Sówka, I. (2022). Preliminary analysis of the state of municipal waste management technology in Poland along with the identification of waste treatment processes in terms of odor emissions. *Archives of Environmental Protection*, 48, 3, pp. 3–20. DOI: 10.24425/aep.2022.142685
- Rolewicz-Kalińska, A., Lelicińska-Serafin, K. & Manczarski, P. (2021). Volatile organic compounds, ammonia and hydrogen sulphide removal using a two-stage membrane biofiltration process. *Chemical Engineering Research and Design*, 165, pp. 69–80. DOI: 10.1016/j.cherd.2020.10.017
- Rybarczyk, P. (2022). Removal of Volatile Organic Compounds (VOCs) from Air: Focus on Biotrickling Filtration and Process Modeling. *Processes*, 10, 12, pp. 2531. DOI:10.3390/pr10122531
- Rybarczyk, P., Marycz, M., Szulczyński, B., Brillowska-Dąbrowska, A., Rybarczyk, A. & Gębicki, J. (2021). Removal of cyclohexane and ethanol from air in biotrickling filters inoculated with *Candida*

- albicans* and *Candida subhashii*. *Archives of Environmental Protection*, 47, 1, pp. 26–34. DOI: 10.24425/aep.2021.136445
- Rybarczyk, P., Szulczyński, B. & Gębicki, J. (2020). Simultaneous removal of hexane and ethanol from air in biotrickling filter – process performance and monitoring using electronic-nose. *Sustainability*, 12, 1, pp. 387. DOI: 10.3390/su12010387
- Rybarczyk, P., Szulczyński, B., Gospodarek, M. & Gębicki, J. (2019). Effects of n-butanol presence, inlet loading, empty residence time and starvation periods on the performance of a biotrickling filter removing cyclohexane vapours from air. *Chemical Papers*, 74, pp. 1039–1047. DOI: 10.1007/s11696-019-00943-2
- Sabilla, S.I., Sarno, R. & Siswantoro, J. (2017). Estimating Gas Concentration using Artificial Neural Network for Electronic Nose. *Procedia Computer Science*, 124, pp. 181–188. DOI: 10.1016/j.procs.2017.12.145
- Salamanca, D., Dobsław, D. & Engesser, K.-H. (2017). Removal of cyclohexane gaseous emissions using a biotrickling filter system. *Chemosphere*, 176, pp. 97–107. DOI: 10.1016/j.chemosphere.2017.02.078
- Schlegelmilch, M., Streese, J. & Stegmann, R. (2005). Odour management and treatment technologies: An overview. *Waste Management*, 25, 9, pp. 928–939. DOI: 10.1016/j.wasman.2005.07.006
- Sohn, J.H., Dunlop, M., Hudson, N., Kim, T.I. & Yoo, Y.H. (2009). Non-specific conducting polymer-based array capable of monitoring odour emissions from a Biofiltration system in a piggery building. *Sensors and Actuators B: Chemical*, 135, 2, pp. 455–464. DOI: 10.1016/j.snb.2008.10.007
- Szulczyński, B., Gębicki, J. & Namieśnik, J. (2018a). Monitoring and efficiency assessment of biofilter air deodorization using electronic nose prototype. *Chemical Papers*, 72, pp. 527–532. DOI: 10.1007/s11696-017-0310-9
- Szulczyński, B., Rybarczyk, P. & Gębicki, J. (2018b). Monitoring of n-butanol vapours biofiltration process using an electronic nose combined with calibration models. *Monatshefte für Chemie*, 149, pp. 1693–1699. DOI: 10.1007/s00706-018-2243-6
- Szulczyński, B., Rybarczyk, P., Gospodarek, M. & Gębicki, J. (2019). Biotrickling filtration of n-butanol vapours: process monitoring using electronic nose and artificial neural network. *Monatshefte für Chemie*, 150, pp. 1667–1673. DOI: 10.1007/s00706-019-02456-w
- Vergara-Fernandez, A., Revah, S., Moreno-Casas, P. & Scott, F. (2018). Biofiltration of volatile organic compounds using fungi and its conceptual and mathematical modeling. *Biotechnology Advances*, 36, 4, pp. 1079–1093. DOI: 10.1016/j.biotechadv.2018.03.008
- Wiśniewska, M., Kulig, A. & Lelecińska-Serafin, K. (2020). Olfactometric testing as a method for assessing odour nuisance of biogas plants processing municipal waste. *Archives of Environmental Protection*, 46, 3, pp. 60–68. DOI: 10.24425/aep.2020.134536
- Wu, X., Lin, Y., Wang, Y., Wu, S., Li, X. & Yang C. (2022). Enhanced Removal of Hydrophobic Short-Chain n-Alkanes from Gas Streams in Biotrickling Filters in Presence of Surfactant. *Environmental Science & Technology*, 56, 14, pp. 10349–10360. DOI: 10.1021/acs.est.2c02022
- Wysocka, I., Gębicki, J. & Namieśnik, J. (2019). Technologies for deodorization of malodorous gases. *Environmental Science and Pollution Research*, 26, pp. 9409–9434. DOI: 10.1007/s11356-019-04195-1
- Yang, C., Chen, H., Zeng, G., Yu, G. & Luo, S. (2010). Biomass accumulation and control strategies in gas biofiltration. *Biotechnology Advances*, 28, 4, pp. 531–540. DOI: 10.1016/j.biotechadv.2010.04.002
- Yu, G., Wang, G., Wang, S., Yang, C., Chen, H., Zhu, Y., Yu, L., Li, J. & Kazemian, H. (2021). Performance promotion and its mechanism for n-hexane removal in a lab-scale biotrickling filter with reticular polyurethane sponge under intermittent spraying mode. *Process Safety and Environmental Protection*, 152, pp. 654–662. DOI: 10.1016/j.psep.2021.06.029
- Zarra, T., Reiser, M., Naddeo, V., Belgiorno, V. & Kranert, M. (2014). Odor Emissions Characterization from Wastewater Treatment Plants by Different Measurement Methods. *Chemical Engineering Transaction*, 40, pp. 37–42. DOI: 10.3303/CET1440007
- Zhang, S., Cai, L., Koziel, J.A., Hoff, S.J., Schmidt, D.R., Clanton, C.J., Jacobson, L.D., Parker, D.B. & Heber, A.J. (2010). Field air sampling and simultaneous chemical and sensory analysis of livestock odorants with sorbent tubes and GC-MS/olfactometry. *Sensors and Actuators B: Chemical*, 146, 2, pp. 427–432. DOI: 10.1016/j.snb.2009.11.028
- Zhang, Y., Ning, X., Li, Y., Wang, J., Cui, H., Meng, J., Teng, C., Wang, G. & Shang, X. (2021). Impact assessment of odor nuisance, health risk and variation originating from the landfill surface. *Waste Management*, 126, pp. 771–780. DOI: 10.1016/j.wasman.2021.03.055

Kontrola procesowa dezodoryzacji strumienia powietrza z par LZO, przeprowadzonej w biofiltrze zraszanym, przy wykorzystaniu matrycy czujników gazowych

Streszczenie: W artykule przedstawiono zasadność, celowość i sensowność zastosowania matrycy czujników gazowych do monitorowania procesów dezodoryzacji powietrza prowadzonych w biofiltrze zraszanym (BTF) z wypełnieniem w postaci torf-perli-pianka poliuretanowa. Celem przeprowadzonych badań była kontrola procesowa skuteczności oczyszczania strumienia powietrza z par związków hydrofobowych, którymi były n-heksan i cykloheksan. Skuteczność usuwania hydrofobowego n-heksanu i cykloheksanu z powietrza oceniono przy użyciu chromatografii gazowej jako techniki referencyjnej oraz skonstruowanej matrycy czujników gazowych składającej się z siedmiu komercyjnie dostępnych czujników. Zbadano wpływ obciążenia złoża (IL) n-heksanu i cykloheksanu na wydajności biofiltracji. Przygotowana matryca czujnikowa została skalibrowana z wykorzystaniem dwóch technik statystycznych: Multiple Linear Regression (MLR) oraz Principal Component Regression (PCR). Opracowane modele matematyczne pozwoliły skorelować wielowymiarowy sygnał z matrycy czujników ze stężeniem usuwanych substancji. Wyniki uzyskane na podstawie analiz chromatograficznych wykazały, że wydajność usuwania n-heksanu i cykloheksanu osiągnęły odpowiednio około 40 i 40 gm-3h-1. Wyniki uzyskane z wykorzystaniem matrycy czujników gazowych wykazały, że możliwe było nie tylko wiarygodne określenie stężeń badanych hydrofobowych lotnych związków organicznych w próbkach gazowych, ale również charakteryzowały się podobnie wysokim poziomem jakości jak wyniki chromatograficzne. Zaproponowana w tej pracy matryca czujników gazowych może być wykorzystana do monitorowania procesu biofiltracji powietrza zanieczyszczonego n-heksanem i cykloheksanem w czasie rzeczywistym.