

Marcin GNYBA, Robert BOGDANOWICZ, Piotr WROCZYŃSKI
Gdansk University of Technology, Gdansk

RAMAN MODULAR SYSTEM WITH FIBRE-OPTIC PROBES FOR REMOTE MONITORING OF CVD PROCESS

Keywords

Raman spectroscopy, *in-situ* monitoring, fibre-optic probes, chemical vapour deposition, diamond thin films.

Abstract

Dedicated Raman system was designed for *in-situ* monitoring of thin film growth in CVD (chemical vapour deposition) process. Review of monitoring requirements and limiting factors is given in this paper. Computer simulation of laser beam propagation in the CVD chamber and the thin film was carried out. Components for Raman optical probes and their configuration were selected using results of the modelling. *Ex-situ* investigation of the thin films enabled determination of the Raman scattering intensity. The prototype of the modular Raman system using fibre-optic probes was built. Efficiency of optical signal transmission through the probes was tested.

Introduction

Manufacturing of modern thin-film optical and microelectronic devices in low-pressure plasma process requires precision and strict control of the process. It is necessary to obtain the required properties and high quality of the final product. It stimulates the searching of effective diagnostic tools. The aim of the presented research is to develop an optoelectronic system, which would enable

in-situ monitoring of growth of diamond/DLC (diamond-like-carbon) thin films. The films are synthesised during μ PA ECR CVD (Microwave Plasma Assisted Electron Cyclotron Resonance Chemical Vapour Deposition) process. A mixture of methane CH_4 and hydrogen H_2 (molar ratio equal to 0.5/99.5%) is used as a precursor. The total gas flow is up to 100 sccm, while the range of its total pressure extends from 1 to 100 mTorr. Plasma is generated in area of Electron Cyclotron Resonance between microwave radiation (frequency $f = 2.45\text{GHz}$, power level $P = 1\text{ kW}$) and constant magnetic field (induction $D = 87.5\text{ mTesla}$). Obtained data about the investigated CVD process will enable its further optimisation and improvement of synthesised film quality. The CVD diamonds can be applied as hard layers in cutting tools and thermal conductivity layers as well as in high frequency electronics and infrared optics [1].

The most significant parameters of the investigated process and the deposited film are as follows: molecular composition of the film (ratio of diamond sp^3 , graphite sp^2 and amorphous phases), the content of defects and rate of the film growth. This information can be provided by Raman spectroscopy - an optoelectronic diagnostic method, which has growing potential in technological process diagnostics. Raman spectroscopy can be used in the investigation of a wide group of dielectric and semiconductor materials. Moreover, recent development in optoelectronics (waveguides, compact lasers, filters, lenses, gratings and integrated detector matrices) enables the building of dedicated Raman systems for on-line monitoring of wide group of manufacturing processes.

Design and setting up the effective system for *in-situ* monitoring requires preliminary theoretical and experimental investigation including the following: (1) determination, if the selected method can be used for studies of particular material, (2) analysis of monitoring requirements and limiting factors, (3) design of optical coupling between the monitoring system and the reaction chamber, (4) calculation of parameters of components of the measurement system and their selection, (5) setting up the prototype. The aforementioned preliminary analysis and investigations are the subjects of the presented paper.

1. Theoretical background

Raman spectroscopy is based on recording and spectral analysis of radiation scattered inelastically by molecules of the investigated object [2, 3]. As a result of interaction between monochromatic light and dipoles induced in oscillating molecules, the spectrum of scattered light may contain wavelengths different than that of the incident beam λ_0 . The difference, referred to as Raman shift, is related to characteristic oscillation frequencies of the molecule, e.g. vibrations of a single molecular bond or a larger fragment of a material network. Thus, parameters of bands in Raman spectrum (i.e. position, intensity, width) provide



information about the molecular structure of the investigated material. However, a particular vibration is Raman active only if it is connected with the change in the polarizability tensor of molecule. It reduces the group of materials, which can be the subject of Raman investigation and stimulates preliminary studies of Raman signal generation in the particular material.

For a given excitation wavelength λ_0 , Raman intensity can be expressed as follows:

$$I_R = I_L \cdot \sigma \cdot K \cdot P \cdot C \quad (1)$$

where: I_R – measured Raman intensity [photons per second], I_L – laser excitation intensity [photons per second], σ – absolute Raman cross-section [cm^2 per molecule], K – a constant accounting for measurement parameters, P – sample path length [cm], C – concentration [molecules per cm^3].

Raman studies of thin films can be carried out as *ex-situ* measurements conducted for a sample outside the reaction vessel after manufacturing process or as *in-situ* monitoring of film deposition. The first mode gives more possibilities of structure investigation while the second one can be used for optimisation of the manufacturing process parameters.

Dependence of Raman signal on sample path length P can be used to determine the thickness of the growing thin film. It can be done by the on-line monitoring of the increase of the intensity of selected Raman bands assigned to the film. The other way is based on the ratio of the bands assigned to the film and substrate.

2. Monitoring system requirements

Effective practical application of Raman spectroscopy requires analysis and the satisfying of several CVD system requirements. Selection of the optimal excitation laser wavelength λ_0 is an important problem in Raman spectroscopy. Intensity of the Raman signal is inversely proportional to λ_0^4 , so, if the intensity of Raman scattering is considered, application of VIS (visible range) or UV (ultraviolet) laser as the excitation source is more effective than an IR (infrared) one. However, fluorescence induced by a laser beam must also be taken to account. The fluorescence is the strongest for the excitation wavelength range from 270 to 700 nm, but its influence can be different for various materials, so it should be determined experimentally for investigated materials. Application of the excitation in UV may be connected with the high price of equipment, the low sensitivity of some detectors (e.g. charge coupled device - CCD arrays) and the risk of unwanted photochemical reactions catalysis, which interfere with a technological process. Because of the complexity of the theoretical selection,



excitation wavelength λ_0 in our measurements must be chosen in an experimental way, by the measurements made with pre-selected excitation wavelengths. The key factor hampering investigation of thin films is a low level of the useful Raman signal, which is result of a small sample path length P (Fig. 1) and attenuation of optical signals in investigated materials. Moreover, existence of strong background radiation must be considered. Raman scattering in the substrate and external radiation are its origin. Raman studies of thin films require precise focusing of the laser beam in the film structure in order to excite the proper part of investigated structure. Sophisticated optical setups must be used to the reduce level of interfering Raman signals originating from the substrate and ensure sufficient sensitivity of the measurement system.

Except for the aforementioned problems, we also have to consider other group connected with *in-situ* monitoring of the process that is important in thin film investigations.

The most serious task is to design an effective optical coupling between the technological chamber and the Raman system. In most processes components of the measurement system should not be placed inside the reaction vessel in order to avoid a decrease of chamber cleanness during the process. Consequently, monitoring systems must have a long working distance, determined by chamber dimensions. Moreover, high-intensity electromagnetic fields used by the CVD system causes the risk of Raman system components damage (e.g. CCD camera), so measurement devices must be placed at a sufficient distance from the chamber. Transmission of the laser beam through the open space is restricted by safety conditions, while transmission of the Raman scattering signal through the open space is ineffective, because of beam divergence and its interference by external light. It stimulates use of fibre-optic probes to transmit optical signals. Consequently, the design of dedicated optical probes and their effective coupling to the CVD chamber is one of most important tasks in case of long-working-distance systems for Raman monitoring. Optical parameters of the coupling and measurement system components have to be matched to reduce scattering and attenuation of optical signals.

A serious problem is caused by optical interfering signals originating from plasma discharge (line spectrum) and thermal emission of the substrate heater (constant spectrum).

3. Preliminary measurements

Preliminary *ex-situ* measurements were made to find the sufficient wavelength λ_0 and estimate the required power density of the excitation. Tests were made for the λ_0 range extending from 472 to 514.5 nm. Examples of the spectra of CVD diamond and monocrystalline diamond are show in Fig.1. The peak at 1333 or 1334 cm^{-1} can be assigned to diamond (sp^3), while amorphous



sp^2 carbon („G”) is the origin of wide bands at 1541 cm^{-1} in part (a) [4]. In the spectrum of CVD thin film, we can also observe a peak at 520 cm^{-1} , assigned to silicon substrate as well as wide-band fluorescence signal, which is result of inhomogeneous structure of the CVD product. Although the fluorescence reduces the sensitivity of the measurement and its influence can be even stronger for doped thin films [5], it can be noticed that main bands are still recognisable in our spectra.

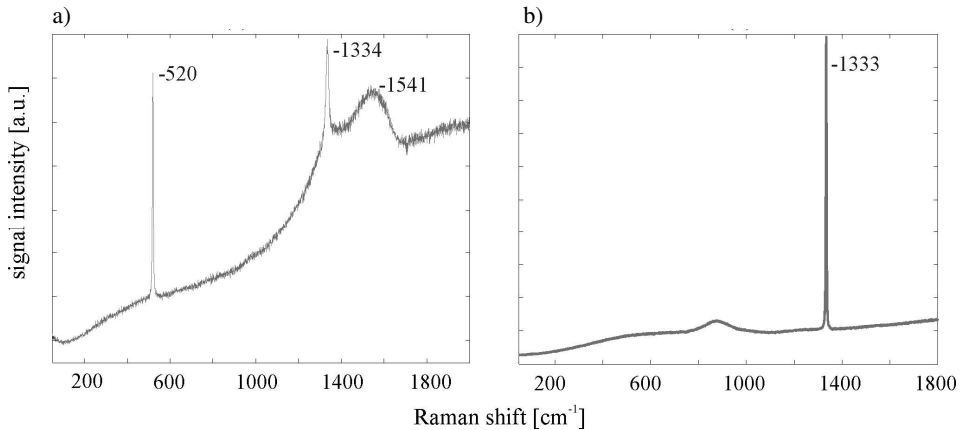

Fig. 1. Comparison between Raman spectrum of: a) CVD diamond thin film, b) monocrystalline diamond (Raman microscope Jobin Yvon T64000, Argon:ion laser $\lambda_0 = 514.5\text{ nm}$)

Similar results were obtained in the whole λ_0 range from 472 to 514.5 nm. Analysis of this data related to results reported by other groups shows that λ_0 values close to 514.5 nm are sufficient for excitation in presented application. However, for some diamond-like materials excitation in UV range (e.g. 355 nm) can be slightly better [5]. The power level of a few milliwatts was strong enough to ensure the time of acquisition sufficient to process dynamics (less than one minute). Consequently, we have chosen a compact solid state laser $\lambda_0 = 532\text{ nm}$. The OES (Optical Emission Spectroscopy) measurements showed that, in respective Raman range, optical interfering signals originating from plasma discharge and the thermal emission of substrate heater should not disturb Raman *in-situ* monitoring [5].

4. Simulations and calculations of optical configuration

The selection of the optical configuration of thin film excitation and the acquisition of Raman scattering signal matched to CVD chamber design (able to investigate thin films through windows of the chamber at working distance about 20 cm) is the next step of the presented research. Main setups are shown



in Fig. 2. Simulation of beam transmission to/from the chamber was made using the Monte Carlo method based on laws of geometrical optics (ray-tracing model). Details of the thin film excitation by the laser beam were subject to the Beam Propagation Method (BPM) modelling and after that – additional calculations.

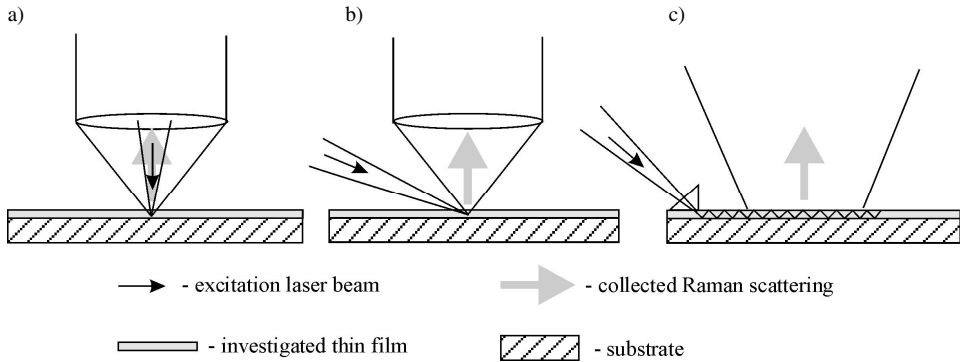

Fig. 2. Optical setups for Raman investigations of thin solid films: a) backscattering configuration, b) glancing-incidence configuration, c) waveguide configuration

4.1. Development of the ray-tracing model

Computer simulations of selected problems of the laser beam transmitting inside the CVD chamber were carried out to enable the fast design of collimating objectives. The proposed model utilises the algorithms based on the laws of geometrical optics [7]. The focusing subsystem was optimised for substrate excitation and scattered Raman signal collection. The laser excitation beam coupling to the CVD chamber was simulated utilising the Monte Carlo ray trace method implemented in the Illumination Module of LightTools software. This ray-tracing package enables to model, analyze and optimize light beam focusing created using lasers and fibres. The Monte Carlo tracing technique offers fast and efficient simulations with thousands of rays [8], so it is a powerful aid to verify the correctness of beam transmitting.

The overview of CVD chamber design is shown in Fig. 3. The figure was prepared using one thousand rays to keep the design more noticeable. A laser source (A) was used as an input the light beam generator with various geometrical parameters and a wavelength of 532 nm.

The receiver plane (B) simulates the acquisition part of the Raman system, and it is applied for scattered beam investigation. The silicon substrate (C) was located inside the chamber. The substrate was covered by the thin layer having optical properties respective to the growing diamond films.

The focusing system were designed using achromatic doublets (diameter $D = 2$ inch) made from optical glasses. Doublets were used to correct on-axis spherical and chromatic aberrations to obtain a small focusing spot at the substrate. The lens and view-ports surfaces were covered by quarter-wave AR coatings with a refractive index $n = 1.38$ fitted to the base material and the wavelength of the excitation laser. The input and output focal lengths were calculated with different lens curvatures. The best results were obtained using focal length $f = 197$ mm as an optimum for the Raman system effectiveness.

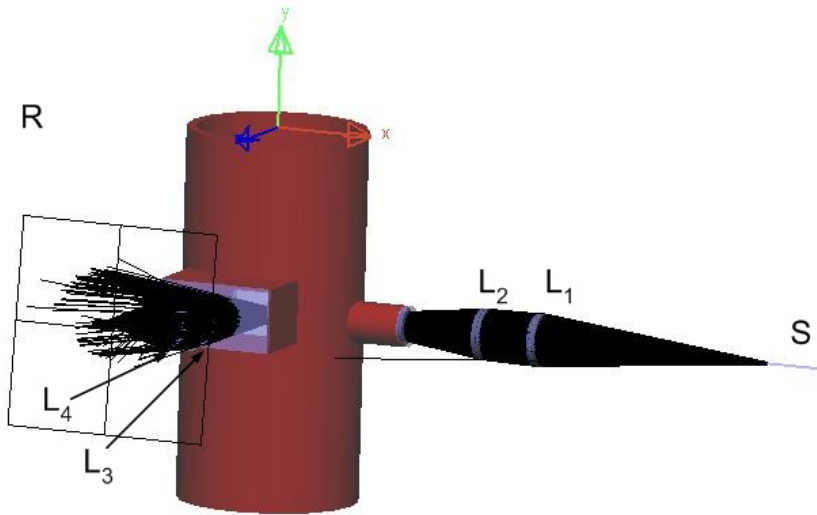

Fig. 3. Model of CVD chamber geometrical configuration: L_1 , L_2 , L_3 , L_4 – lenses, S – source, R – receiver plane

The long-distance sample excitation and scattered light beam collecting were simulated simultaneously to obtain the high efficiency of the Raman system. All parts of the analysis were performed in the wavelength range extending from 525 nm to 535 nm. The farther simulation results were carried out using a million rays with lambertian angular distribution at the maximum angle 15 degrees (output of typical optical waveguides). Precision ray trace mode was used to obtain more accurate results.

The scatter chart was used to give an overall picture of the ray intersections. It is very useful as a diagnostic tool, showing "holes" in the ray distributions where they are not expected, or ray intersections where none are expected. This can give clues to any errors in the model setup.



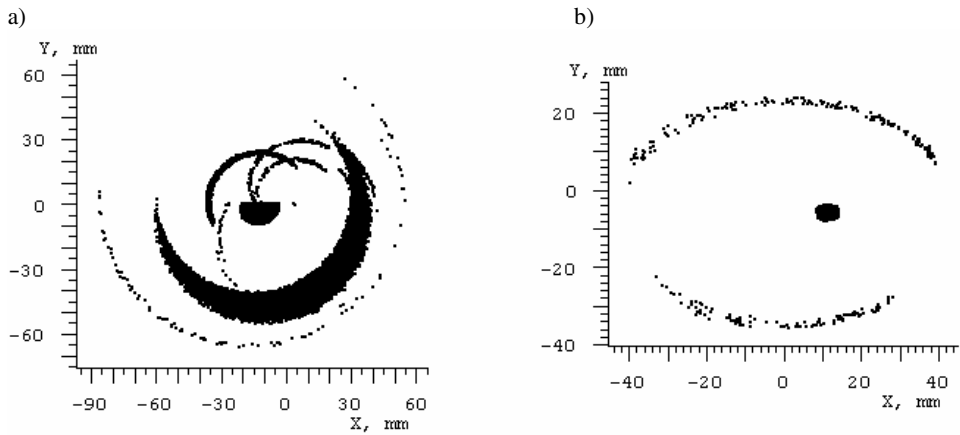

Fig. 4. The scatters chart of the rays at: a) the receiver plane/acquisition part and b) sample

Scattering of the light beam is shown in Fig. 4. The ray-tracing sub-sets simulation was performed in the acquisition plane outside the chamber (a) and at the sample located in the CVD bell-jar (b). Designed achromatic lens enabled high efficiency of the beam focusing. The diameter of a light spot at the substrate is less than 2 mm (Fig. 4b). Moreover, only 1% of the rays are transmitted outside the focusing objective giving the semicircle effect at the diagram. This effect is caused by rays with a high angular position, which were not caught in the lens plane considering the limited diameter of collimating optics. It could be further reduced by a higher diameter of objectives or by adding small irises cutting the rays with higher angular positions. The second way is more flexible, because it offers low-cost cutting rays with various angular positions using the different iris diameters.

The output objective and receiver plane were placed at 4 degrees deviation from the normal angle to the sample surface. It was caused by the chamber construction and the output view-port position. It was noticed that the diameter of the main beam spot at the receiver is 12 mm (Fig. 4a), which matched with parameters of acquisition probe and multi-fibre bundle.

Similarly, the semicircle effect of the sample could also be observed for the receiver place. In this case, about 5% are not properly focused, but it is not critical to obtaining the optimal signal level at the acquisition system. It will be corrected in a similar way to the excitation part in the next step of system development by the irises inclusion. Moreover, the angular position of the receiving objective could be shifted to minimise the amount of rays transmitted outside the lens plane.

Summarizing, the long-working-distance Raman system was a subject of computer modelling. It was found that the most important factor for proper



focusing is to correct the spherical aberrations by the doublets. The focal length of collimation objectives has been matched to obtain efficient sample excitation. A more sophisticated lens and viewport surface treatment was required (e.g. quarter-wave AR layer) to minimise the optical power loss.

4.2. Beam propagation method

Different configurations of thin-film sample excitation were the subject of modelling by the BPM (beam propagation method), based on the laws of wave optics [9] because of the small dimensions of investigated objects. An example is shown in Fig. 5.

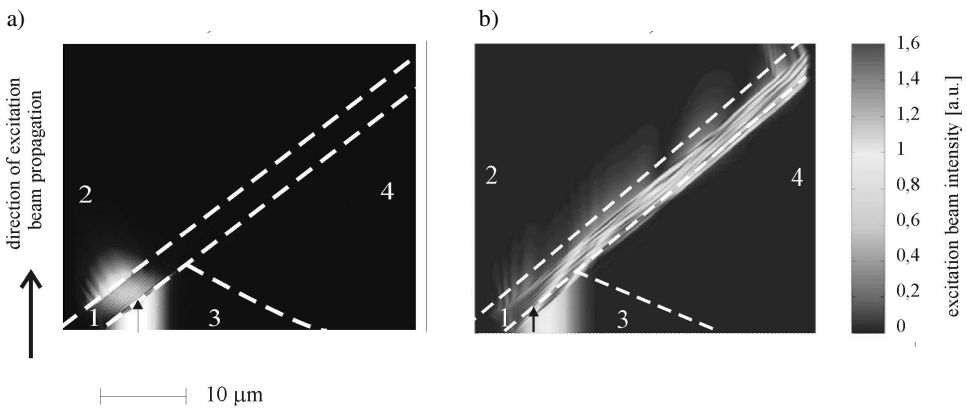

Fig. 5. Example of BPM simulations for waveguide configuration using prism coupling of the laser beam to the diamond film deposited on silicon substrate: a) point excitation of the film followed by attenuation in the substrate, b) partial waveguide effect – amplification of the Raman signal; (1 – thin film – diamond, 2 – substrate – silicon, 3 – prism – $n = 2,696$, 4 – air)

Analysis and results of BPM modelling suggests that glancing-incidence configuration is the most sufficient. Internal reflection effect in the thin film, used in waveguide configuration, is present but weak when silicon substrate is used. Prism coupling would be difficult to apply in *in-situ* monitoring. The most effective incidence angle can be calculated for most common sets of film and substrates

4.3. Calculation of focusing area dimensions

We made additional calculations of the theoretical diffraction limits of focusing area dimensions for parameters of the excitation part, pre-selected by computer simulations. Calculations of the focusing area of the excitation beam



were made using equations (2) and (3)[3]. Diameter d – theoretical limit of laser spot width can be expressed as follows:

$$d = \frac{4 \cdot \lambda_0 \cdot f}{\pi \cdot D} \quad (2)$$

The effective length L of the focusing area can be expressed as follows:

$$L = \frac{16 \cdot \lambda_0 \cdot f^2}{\pi \cdot D^2} \quad (3)$$

We assumed: λ_0 is equal to 532 nm; working distance of the excitation probe equal to focal length of objective $f = 197$ mm; diameter of the laser beam D is about 50 mm – slightly smaller than diameter of achromatic doublets. For these values $d = 2.67 \mu\text{m}$ and $L = 42 \mu\text{m}$. After a comparison with results of Raman microscope measurements (spot diameter $\sim 1 \mu\text{m}$ [3], power on sample \sim a few milliwatts), we can estimate that power level on the sample at about 20-30 mW should be sufficient for long-working-distance monitoring systems using excitation singlemode waveguide, to achieve sufficient time of acquisition. If multimode waveguide is used, the required power level would be slightly higher, because of larger laser spot.

5. Set up of the Raman system

The setup of the Raman system using glancing-incidence configuration, coupled with CVD chamber and having working distance equal to 197 mm is shown in Fig. 6.

All components of the Raman system are placed outside the CVD chamber and remote access is provided. Optical signals are transmitted through the 5-meters long optical waveguides (thus protecting sensitive detection part), dedicated probes and windows in the chamber walls. Solid state laser Roitner DPSSL-200 ($\lambda_0 = 532$ nm, line width – 0.1 nm, output power - 200 mW, TEM₀₀ transverse mode) is used. Spectrograph Kaiser HoloSpec f/1.8i with holographic grating provides high throughput and Raman range 20-2360 cm^{-1} with spectral resolution better than 5 cm^{-1} . TE-cooled CCD detector Andor DV-401-BV ensures low level of noise.

Preliminary adjustment of the experimental system (outside CVD chamber) enabled the focusing of a beam having sufficient optical power (50 mW) on the sample placed 20 cm from the excitation probe - working distance which enables transmission of the beam through the chamber window (non-contact measurements). Modular setup of the Raman system enables its further modifications, e.g. change of wavelength λ_0 of the excitation laser beam (e.g. to 355 nm) by replacement of laser, grating and filters.



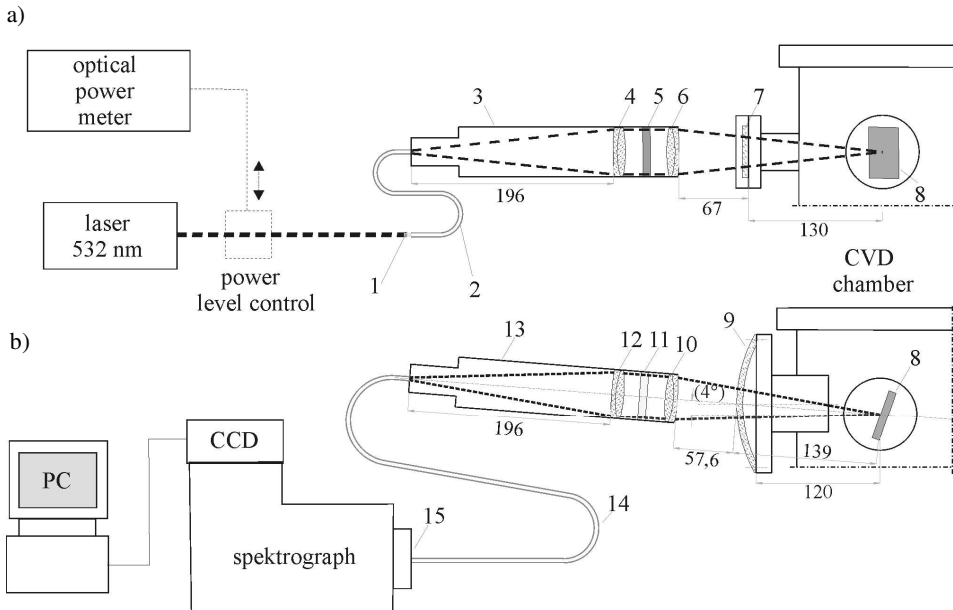

Fig. 6. Design of Raman system for *in-situ* monitoring of μ PA CVD process: a) excitation part, b) acquisition part; 1 – coupler, 2 – optical fibre, 3 – excitation probe, 4–6 – objective, 5 – bandpass filter, 7 – window, 8 – growing film, 9 – window, 10–12 – objective, 11 – notch filter, 13 – collecting probe, 14 – fibre bundle, 15 – adapter; dimensions are given in millimeters

Conclusions

The presented research is a preliminary level of our work on the Raman system for CVD process monitoring. Requirements of the Raman system were analysed and defined. Theoretical studies and microscopic measurements confirmed the high efficiency of Raman spectroscopy in studies of carbon thin films growth. It was shown that the Raman spectra provide information about molecular structure of the film as well as about the increase of its thickness. Design work of the Raman system dedicated for *in-situ* monitoring of CVD processes was done and aided by computer modelling. Computer simulations showed that the system should work in glancing-incidence and have a working distance about 20 cm to be matched with the used CVD chamber. Components of the measurement system (e.g. laser, filters, waveguides and lenses) were selected and parameters were calculated. Dedicated optical waveguide probes enable a safe distance between the CVD chamber and sensitive components of the Raman system (e.g. CCD camera). The prototype was set up and its excitation part was tested. Obtained results enable further work on adjustment

of the system and its mounting. We expect that this configuration would enable thin film *in-situ* measurements during the deposition. The influence of technological process parameters on its efficiency and product quality will be studied. *On-line* measurements will give the opportunity of process optimisation in the real time.

Acknowledgements

Scientific work financed by the Ministry of Science and Higher Education and carried out within the Multi-Year Programme "Development of innovativeness systems of manufacturing and maintenance 2004–2008".

References

1. May P.W.: Diamond thin films: a 21st-century material. *Phil. Trans. R. Soc. Lond.*, Vol. 358, 473–495.
2. Pelletier M.: *Analytical Applications of a Raman Spectroscopy*. Blackwell Science, Oxford, 1999.
3. Bowley H.J., Gardiner D.J., Gerrard D.L., Graves P.R., Loudon J.D., Turrel G.: *Practical Raman Spectroscopy*. Springer Verlag, Berlin, 1991.
4. Fabisiak K.: *Analiza defektów w cienkich polikrystalicznych warstwach diamentowych otrzymanyh metodami CVD*. Wydawnictwo Uniwersytetu Mikołaja Kopernika, Toruń, 1994 (in Polish).
5. Mermoux M. et al.: Raman characterization of boron-doped {111} homoepitaxial diamond layers. *Diamond and Related Materials*, Vol. 15, 4–8, 572–576.
6. Bogdanowicz R., Gnyba M., Wroczyński P.: Optoelectronic monitoring of plasma discharge optimized for thin diamond film synthesis. *Journal de Physique*, Vol. 137, 57–60.
7. Born M., Wolf E.: *Principles of optics*. Cambridge University Press, 1999, 167–178.
8. Rubinstein R.Y.: *Simulation and the Monte Carlo method*. J. Wiley & Sons Inc., New York, 1981, 67–94.
9. Marciniak M.: *Modelowanie falowodów optycznych metodą propagacji wiązkim*. Wydawnictwa Komunikacji i Łączności, Warszawa, 1995 (in Polish).

Reviewer:

Ryszard M. KOZŁOWSKI



Modułowy system ramanowski z sondami światłowodowymi do zdalnego monitorowania procesów CVD

Słowa kluczowe

Spektroskopia ramanowska, monitoring *in-situ*, sondy światłowodowe, CVD, cienkie warstwy diamentowe.

Streszczenie

W artykule przedstawiono projekt systemu ramanowskiego do monitorowania *in-situ* wzrostu cienkich warstw w procesie CVD i analizę związanych z tym problemów metrologicznych. Na podstawie wyników modelowania komputerowego wprowadzania wiązki laserowej do komory i jej propagacji w cienkiej warstwie wytypowano optymalną konfigurację optyczną systemu ramanowskiego i określono parametry optyczne jego elementów. Zbudowano prototyp modułowego wyposażonego w sondy światłowodowe. Wykonano pomiary wstępne obejmujące badania *ex-situ* generacji sygnału ramanowskiego w wybranych materiałach oraz testy sondy nadawczej na stole optycznym.



