



RELIABILITY MODEL OF SLIDE BEARINGS WITH PARTICULAR ATTENTION GIVEN TO LUBRICATING OIL

Piotr Bzura

Gdansk University of Technology
ul. Narutowicza 11/12, 80-952 Gdańsk, Poland
tel. +48583472573

ABSTRACT

The paper presents the slide bearing with circulating lubrication as a system of series three-element structure, where lubricating oil is the weakest link. In accordance with the Pierce statement that "strength of chain is the strength of its weakest link", a bearing reliability model has been developed. It allows to use the lubricating oil to evaluate the probability of correct working of the whole slide bearing, i.e. the reliability. The lubricating oil was taken from the dynamically loaded radial slide bearing fatigue strength testing stand "Smok" ("Dragon"). Lubricity tests were carried out in the friction node of the "T-02" four-ball extreme pressure tester, with balls dipped in the oil samples. Then, from the analysis and evaluation of test results, probabilities of correct bearing operation were determined.

Key words: cumulative stimuli, slide bearings, reliability, lubricating oil

1. Introduction

An important place among the causes of the slide bearing unserviceability has the wear (ageing) of all the bearing elements (i.e. journal, liner and the separating substance). Regardless of the initial constructional perfection of the bearing elements, they undergo irreversible changes in course of time. The wear of journal and liner is caused, among other reasons, by corrosion, deformation and material fatigue. The most harmful to a slide bearing is the loss of lubricity, which leads to technically dry friction and diffusion of one bearing material into the other.

The processes of corrosion, deformation etc. taking place e.g. in the combustion engine crankshaft bearing cause increased clearances. Due to the material fatigue, during the crankshaft rotation particles break off and adhere. In effect of those processes, the clearance gradually increases and the boundary layers get broken (i.e. the bond of lubricating oil with the journal or liner surface is broken).

The paper presents a wear model allowing to evaluate the slide bearing reliability from the analysis of oil lubricity.

2. Unserviceability of slide bearings

The criterion of slide bearing unserviceability classification is connected with the place of defect occurrence. This way the weakest "link" of the bearing can be detected and the minimum time of bearing correct operation determined.

With such attitude, the bearing will be treated as a system with series structure consisting of three elements [3]: journal, lubricating oil, liner.

The bearing reliability structure is shown in Fig.1.

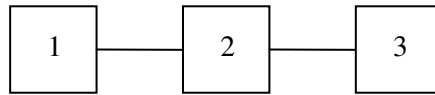

Fig. 1. Diagram of bearing as a system with series structure: 1 – journal, 2 – lubricating oil, 3 - liner

Durabilities of the system individual elements are random variables T_1 , T_2 , T_3 and their realizations are t_1 , t_2 , t_3 , respectively. The system durability is T with realization t . The series structure system definition indicates that:

$$t = \min(t_1, t_2, t_3) \quad (1)$$

and that the system reliability $R(t) = P(T > t)$ is a product of probabilities: $P(T_1 > t)$, $P(T_2 > t)$, $P(T_3 > t)$:

$$R(t) = P(T_1 > t) \cdot P(T_2 > t) \cdot P(T_3 > t) \quad (2)$$

Additionally, the classification criterion allows to detect the reasons of defect occurrence at a given place.

The wear of slide bearings caused by action of cumulative stimuli [4] is only an indirect reason of defects. The bearing wear leading to an excessive clearance, mentioned in the introduction above, may cause a seizure. In such case no admissible values of clearance as a structural parameter can be determined for the journal and liner. The wear process only increases the bearing defect occurrence probability. For this type of defect the gradual bearing wear and the sudden change of its state to unserviceability occur jointly. As the changes of bearing technical condition occur suddenly and are a result of cumulative stimuli, the bearing unserviceability is caused by relaxation stimuli [4].

One of the three mentioned bearing elements is lubricating oil, which is also subjected to the action of cumulative stimuli in the form of loads. In effect of those stimuli the lubricity decreases, which leads to dry friction and in the worst case to seizure.

Therefore, in order to allow estimation of the parameters indicating the slide bearing inefficiency due to cumulative stimuli, a model of the lubricating oil wear has been developed.

3. Model of the lubricating oil wear

In order to maintain the bearing as a whole in the fitness for use condition, the respective characteristics of its components must be kept within strictly defined ranges determined during the bearing tests. Therefore, the bearing clearance should allow correct operation and prevent the dry friction occurrence. When one of the working characteristics (e.g. the working characteristic of the lubricating oil) exceeds the admissible limit and the bearing begins to function defectively, this is treated as bearing unserviceability.

The lubricating oil working characteristic (Fig. 2) deteriorates constantly as an effect of its ageing. It may be assumed that the bearing unserviceability will occur when the lubricating oil lubricity exceeds the admissible limit. The bearing correct operation time "T" is counted until the moment when the oil working characteristic exceeds the established limit value. Fig. 2 presents the situation when at randomly chosen moments single stimuli with determined value occur. After "r" such stimuli the bearing as a whole becomes unserviceable. Action of a

single stimulus demonstrates itself as a stepwise decrease of the oil lubricity by a certain value "y" [4].

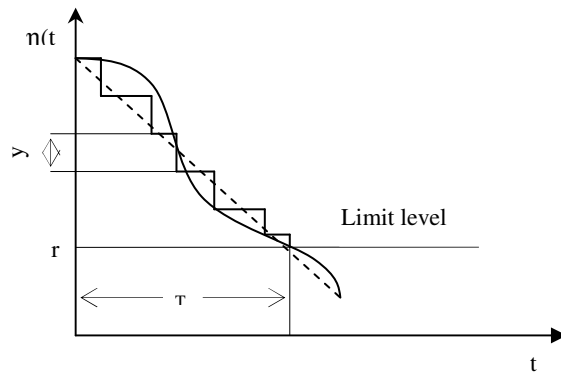

Fig. 2. Realization of the oil characteristic deterioration process as an effect of cumulation of the impairing stimuli: $\eta(t)$ – working characteristic of the lubricating oil; t – time; T – correct operation time, oil durability; r – number of stimuli necessary to make the oil useless; y – oil wear step

The wear model may be considered useful when it pertains to the stabilized wear period (i.e. normal wear). Then the probability of wear increase occurring in the time interval from "t" to "t+ Δt " does not depend on the number of such increases in the time interval from 0 to t. Therefore, it is assumed that probability of each subsequent stimulus action does not depend on the total effect of all the preceding stimulus actions.

Opinion regarding the usefulness of investigation results (e.g. slide bearing wear determined from the lubricating oil properties) for confirming the suitability of the described model can be derived from observation of the realization of wear process. Fig. 3 and 4 present a realization of the bearing wear process (which may be used in these considerations) with "short" wearing-in period compared with the normal wear period, when mean value of the wear speed is the same for all bearings [4,5,6,9].

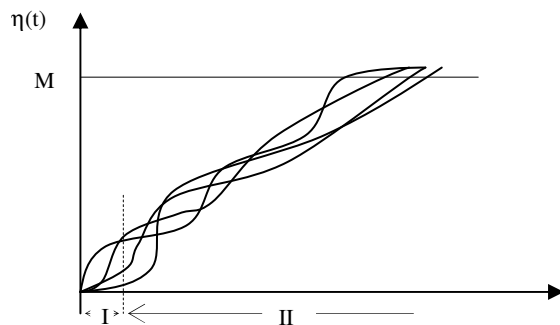

Fig.3. Realization of the bearing wear process: M – wear admissible limit; I – wearing-in period; II – normal wear period

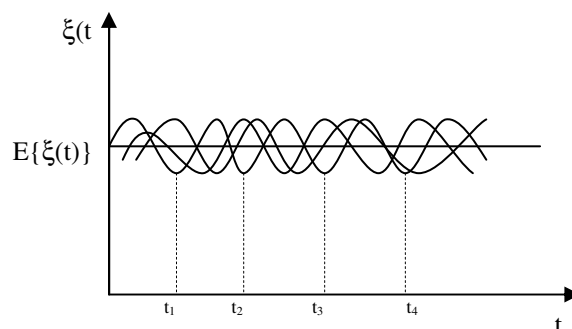

Fig.4. Variable speed of bearing wear during the normal wear period (mean value of the wear speed is the same for all bearings); $E\{\xi(t)\}$ – expected value of the wear speed

In the presented realization of the bearing wear process (Fig.3) the individual wear realizations exceed the admissible wear level M before a disastrous effect occurs. After the end of wearing-in the wear realizations alternate. After elapsing of the wearing-in period the mean value of the wear speed is constant (Fig.4).

When on the basis of the investigation results a bearing wear model may be considered suitable, then it is assumed that the bearing durability (time to failure) has the gamma distribution. Then the value of the probability of correct work for the time t can be determined in a simple way from the nomogram presented in Fig.5.

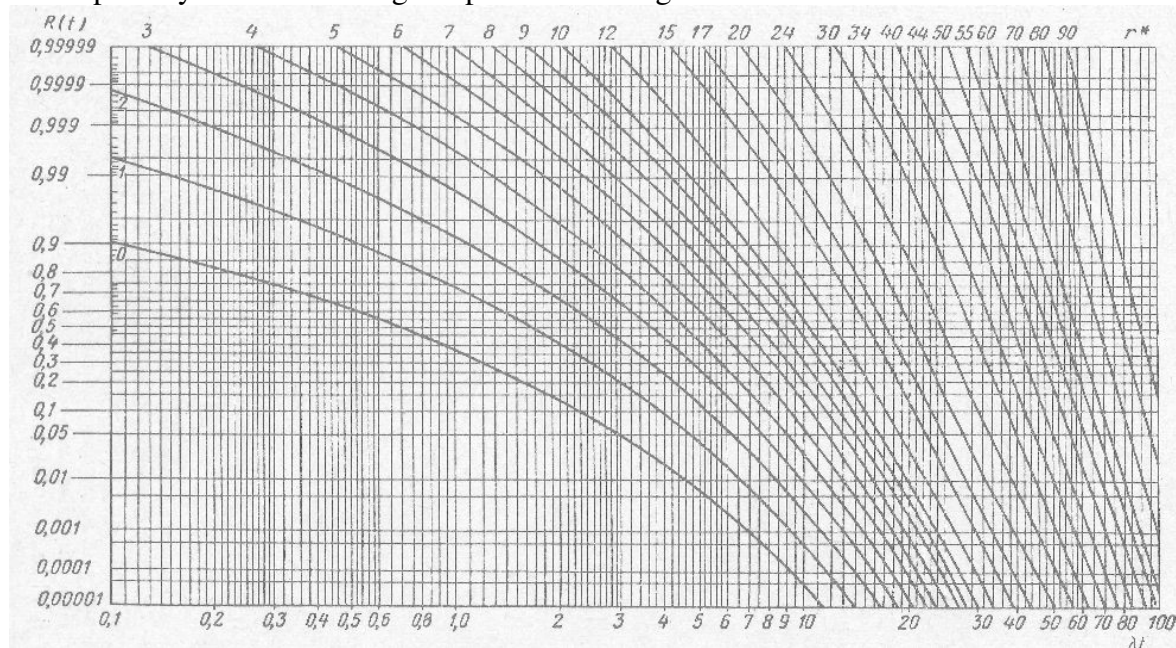

Fig.5. Nomogram for determining reliability $R(t)=P(T>t)$ according to gamma distribution: $r^*=r-1$

After completion of the empirical investigations and following the above presented considerations, the probability was estimated of the slide bearing correct operation. The basis for the probability estimation were results of the mentioned tests carried out with the T-02 four-ball extreme pressure tester.

4. Experimental investigations

For determination of the lubricating oil working characteristics the T-02 four-ball tester was used as a simple physical model of a friction node (Fig.6). The rubbing system in the tester consists of four 12.7 mm diameter balls made from the ŁH15 steel in the accuracy class 16 in accordance with the PN-83/M-86452 standard. Three balls are in the cup-shaped lower holder where the lubricating oil is poured to. The fourth ball is placed in the upper holder. Balls in the cup are pressed against the ball in the upper holder by means of a special lever. During testing the values of journal load, journal rotational speed and lubricating oil temperature can be controlled.

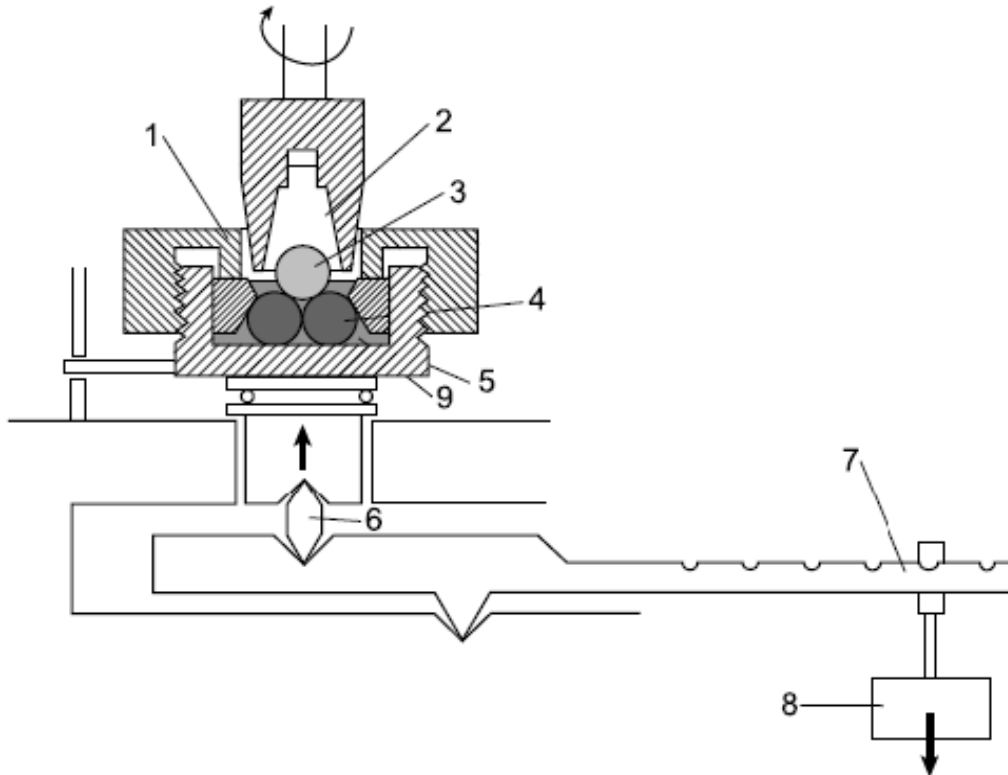

Fig. 6. Kinematic diagram of the four-ball tester: 1 – cover fixing the lower balls, 2 – upper ball holder, 3 – upper ball (rotating), 4 – lower balls (fixed), 5 – tested grease vessel, 6 – prism, 7 – lever, 8 – loads, 9 – tested grease [8].

Measurements were carried out in the T-02 four-ball tester friction node with balls dipped in the Selektor Specjal 20W40 oil sampled from the slide bearing of a "Smok" diagnostic stand [10].

Experimental investigations were carried out with:

1. Oil sampled on 19.01.2011 at 12.15 hrs. – symbol 1.
2. Oil sampled on 19.01.2011 at 14.15 hrs. – symbol 2.
3. Oil sampled on 19.01.2011 at 16.15 hrs. – symbol 3.
4. Oil sampled on 19.01.2011 at 18.15 hrs. – symbol 4.
5. Oil sampled on 20.01.2011 at 10.00 hrs. – symbol 5.
6. Oil sampled on 20.01.2011 at 13.30 hrs. – symbol 6.
7. Oil sampled on 20.01.2011 at 17.00 hrs. – symbol 7.

Slide bearings of the "Smok" diagnostic stand worked with different loads and in a wide range of rotational speed. Therefore, the T-02 four-ball tester measurements were carried out with different loads and different rotational speeds. There were 350 measurements performed altogether, in accordance with the following procedures:

- designation of the time "t" of breaking the boundary layer with constant increase of load at the spindle rotational speed of 500 rpm,
- designation of the time "t" of breaking the boundary layer with constant increase of load at the spindle rotational speed of 525 rpm,
-
- designation of the time "t" of breaking the boundary layer with constant increase of load at the spindle rotational speed of 1725 rpm.

After completion of the measurements (Table 1) a visual analysis was carried out of the realization of the lubricating oil wear process (Fig.7).



Table 1. Numerical data on breaking the boundary layer

Object no.	Spindle rotational speed n [rpm]																																																																																																																																																																																																																																																																																																																																																										
	500	525	550	575	600	625	650	675	700	725	750	775	800	825	850	875	900	925	950	975	1000	1025	1050	1075	1100	1125	1150	1175	1200	1225	1250	1275	1300	1325	1350	1375	1400	1425	1450	1475	1500	1525	1550	1575	1600	1625	1650	1675	1700	1725																																																																																																																																																																																																																																																																																																									
i	Boundary layer breaking time τ [s]																																																																																																																																																																																																																																																																																																																																																										
1	2	3	4	5	6	7	8	9	10	11	12	13	14	15	16	17	18	19	20	21	22	23	24	25	26	27	28	29	30	31	32	33	34	35	36	37	38	39	40	41	42	43	44	45	46	47	48	49	50																																																																																																																																																																																																																																																																																																										
4,64	4,67	4,67	5,47	5,39	4,62	4,87	5,15	4,62	4,38	4,60	4,97	4,59	4,57	5,14	5,23	4,34	4,55	4,91	4,51	4,53	5,05	5,17	4,30	4,51	4,85	4,43	4,48	4,97	5,10	4,25	4,46	4,79	4,35	4,44	4,88	5,04	4,21	4,42	4,73	4,28	4,40	4,80	4,98	4,17	4,37	4,67	4,20	4,35	4,71	4,92	4,13	4,33	4,61	4,13	4,31	4,63	4,85	4,09	4,29	4,55	4,06	4,27	4,55	4,79	4,05	4,25	4,50	3,99	4,22	4,47	4,74	4,01	4,20	4,44	3,92	4,18	4,40	4,68	3,97	4,16	4,39	3,85	4,14	4,32	4,62	3,93	4,12	4,33	3,79	4,10	4,25	4,56	3,89	4,08	4,28	3,72	4,06	4,17	4,51	3,85	4,04	4,23	3,66	4,02	4,10	4,45	3,81	4,00	4,17	3,59	3,98	4,03	4,39	3,77	3,96	4,12	3,53	3,94	3,96	4,34	3,74	3,92	4,07	3,47	3,90	3,89	4,29	3,70	3,88	4,02	3,41	3,86	3,82	4,23	3,66	3,84	3,97	3,35	3,82	3,76	4,18	3,63	3,80	3,92	3,29	3,78	3,69	4,13	3,59	3,77	3,87	3,24	3,75	3,63	4,08	3,55	3,73	3,82	3,18	3,71	3,57	4,03	3,52	3,69	3,78	3,12	3,67	3,50	3,98	3,48	3,66	3,73	3,07	3,64	3,44	3,93	3,45	3,62	3,68	3,02	3,60	3,38	3,88	3,42	3,58	3,64	2,97	3,57	3,33	3,83	3,38	3,55	3,59	2,91	3,53	3,27	3,78	3,35	3,51	3,55	2,86	3,49	3,21	3,74	3,32	3,48	3,51	2,81	3,46	3,16	3,69	3,28	3,44	3,46	2,77	3,43	3,10	3,65	3,25	3,41	3,42	2,72	3,39	3,05	3,60	3,22	3,38	3,38	2,67	3,36	2,99	3,56	3,19	3,34	3,33	2,62	3,32	2,94	3,51	3,15	3,31	3,29	2,58	3,29	2,89	3,47	3,12	3,28	3,25	2,53	3,26	2,84	3,42	3,09	3,24	3,21	2,49	3,23	2,79	3,38	3,06	3,21	3,17	2,45	3,19	2,74	3,34	3,03	3,18	3,13	2,41	3,16	2,70	3,30	3,00	3,15	3,09	2,36	3,13	2,65	3,26	2,97	3,12	3,06	2,32	3,10	2,60	3,22	2,94	3,09	3,02	2,28	3,07	2,56	3,18	2,91	3,06	2,98	2,24	3,04	2,52	3,14	2,88	3,02	2,94	2,20	3,01	2,47	3,10	2,85	2,99	2,91	2,17	2,98	2,43	3,06	2,83	2,97	2,87	2,13	2,95	2,39	3,02	2,80	2,94	2,84	2,09	2,92	2,35	2,99	2,77	2,91	2,80	2,06	2,89	2,31	2,95	2,74	2,88	2,77	2,02	2,86	2,27	2,91	2,72	2,85	2,73



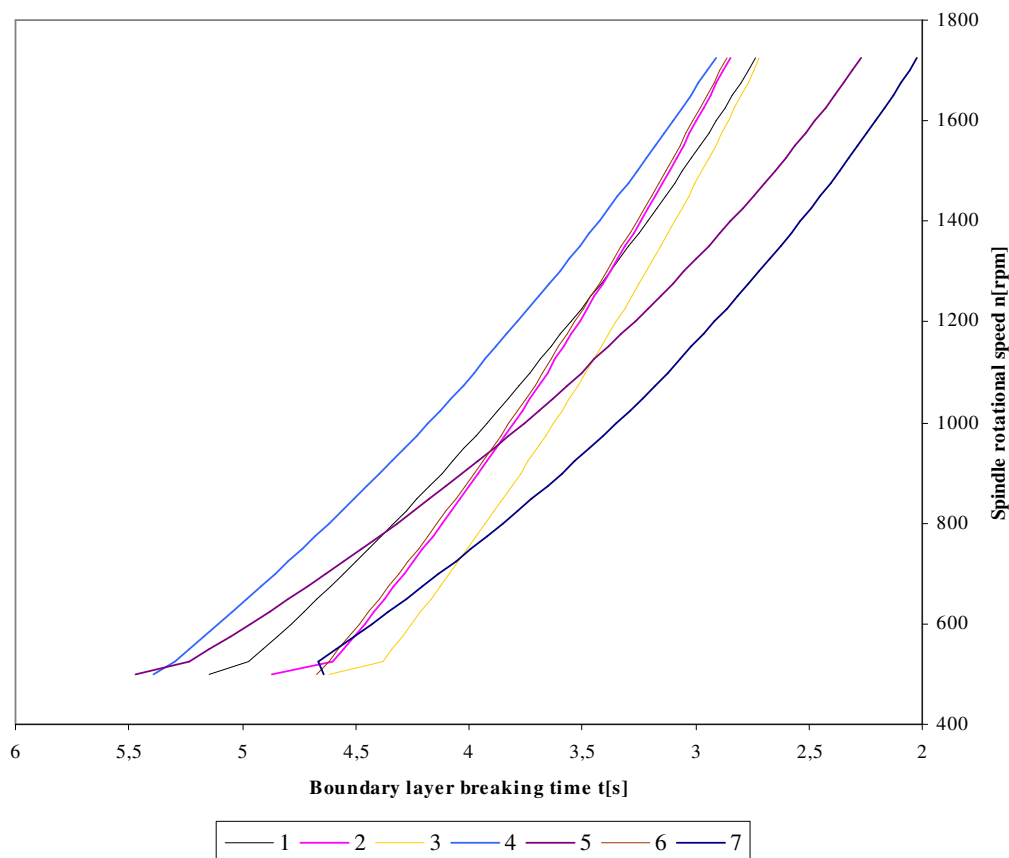

Fig.7. Realization of the lubricating oil wear process

Fig.7 indicates that the individual wear realizations alternate and the average wear speed is constant, therefore the presented lubrication oil wear model may be recognized as useful.

It may also be assumed that the reliability model of the tested oil corresponds with the gamma distribution [4]. Data given in Table 1 allow to estimate the λ (i.e. intensity of damage) and r (i.e. the number of stimuli necessary to cause unserviceability) parameters as well as probability of correct operation during $t_1=2.5$ s and $t_2= 5$ s time.

Table 2. Estimation of reliability parameters

Object no.	$\bar{t} = E(t)$	$s_t^2 = D(t)$	$\lambda^* = \frac{\bar{t}}{s_t^2}$	$r^* = \frac{(\bar{t})^2}{s_t^2}$
1	3,64	0,48	7,65	27,81
2				
3				
4				
5				
6				
7				

As the coefficient of variation is greater than 0.34, the gamma distribution will be applied [4]. Using the nomogram (Fig.5), from the boundary layer breaking time the probability of the tested lubricating oil correct operation can be found: $P(T > 2.5)=0.9$ and $P(T > 5)=0.02$.

5. Final remarks and conclusions

Rational operation of a slide bearing [5,7], consisting of three elements, is possible when the operating characteristics are known, mainly the reliability including durability of the weakest link. In practice, the weakest link of a bearing with circular lubrication is the lubricating oil. Therefore, reliability of a slide bearing as a series structure system depends first of all on the oil durability. Main parameter defining the oil durability is its lubricity [1,2]. It is then necessary to be able to estimate continuously the lubricity realization time in real conditions.

The presented reliability model of the slide bearing lubricating oil is used for analysing and evaluation of the oil lubricity when loads increase. Investigations were carried out in laboratory and the reliability model was a four-ball tester. The lubricating oil was sampled from the "Smok" diagnostic stand slide bearings.

The paper presents a method of determining the bearing lubricating oil reliability by measurements of the oil lubricity. Such tests should be carried out in real conditions, using the presented reliability model, which may be considered suitable for such tests.

References

1. Bzura P.: The use of spectrometric diagnostics in identification of the technical condition of tribological systems. Journal of Polish CIMAC (vol.3, No.2), Gdańsk 2008
2. Bzura P.: Effect of lubricity on the tribological system operation, (in Polish) Zeszyty Naukowe Akademii Marynarki Wojennej, 178A / red. Cz. Dyrz. - Instytut Konstrukcji i Eksploatacji Okrętów AMW. - Gdynia: Wydaw. AWM. – 2009.
3. Czajgucki Z.,J.: Niezawodność spalinowych siłowni okrętowych. Wydawnictwo Morskie. Gdańsk 1984
4. Gercbach I.B., Kordonki CH.B.: Modele niezawodnościowe obiektów technicznych. Wydawnictwo Naukowo-Techniczne, Warszawa 1968
5. Haviland R.P.: Niezawodność urządzeń technicznych. Państwowe Wydawnictwo Naukowe, Warszawa 1968
6. Hebda M., Mazur T., Pelc H.: Teoria eksploatacji pojazdów. Wydawnictwo Komunikacji i Łączności. Warszawa 1978
7. Niziński St.: Elementy eksploatacji obiektów technicznych. Wydawnictwo Uniwersytetu Warmińsko-Mazurskiego, Olsztyn 2000
8. Szczerek M., Muszyński W.: Badanie tribologiczne. Zacieranie. Radom: Biblioteka Problemów Eksploatacyjnych 2000.
9. Włodarski J.,K.: Uszkodzenia łożysk okrętowych silników spalinowych. Akademia Morska w Gdyni, Gdynia 2003
10. http://www.kkiem.mech.pg.gda.pl/dzialalnosc/lab_stanowiska/SMOK.html



Województwo
Zachodniopomorskie

The paper was published by financial supporting of
West Pomeranian Province

