

Ring thruster – a preliminary optimisation study of ferrofluid seal and propeller

Zbigniew Szydło, Ph.D.
Leszek Matuszewski, Ph.D.

ABSTRACT

The article reports the course of preliminary examination of a ferrofluid seal applied in liquid environment. A newly built research rig is described, and results of pressure tests performed for different shaft rotations are discussed. Other studies carried out in the past only referred to the gas environment, while the present examination aims at finding an answer to the question whether magnetic liquids can be successfully used in underwater applications. The obtained answer is positive, but further, more comprehensive investigations of the problem are necessary.

Keywords : ferrofluid seals, underwater propulsion

FERROFLUID SEAL – GOAL AND SCOPE OF EXAMINATION

The goal of the examination was preliminary assessment whether a chamber filled with water in motion can be effectively sealed with the aid of a magnetic liquid seal.

It was assumed that the examination would be carried out for the pressure of the working agent (usable water) equal at least to 1.0 MPa, and for different rotational speeds of the seal, increased from the minimum value of 125 rev/min to the value at which the seal loses its tightness.

Eight hours of continuous work of the seal without loss of tightness was assumed as a preliminary criterion of correct seal operation.

RESEARCH RIG

The Seal Technology Laboratory in the Department of Machine Design and Operation, AGH, Krakow, has three

research rigs used for testing magnetic liquid seals. On these rigs, properties of the seals when in operation in gas environment are examined. In one of those rigs, labelled as MAST-1, constructional changes were introduced to allow it to be used for examining magnetic liquid seals in operation in liquid (usable water) environment. The essence of the introduced changes consisted in mounting an elastic membrane at the end of a hollow shaft to separate the gas, supplied from outside to the shaft hollow, from the area of a chamber created by the examined magnetic liquid seal, cover, screen and membrane, and filled with the working (sealed) liquid.

Fig. 1 shows half-cut/half-view of the measuring head after introducing constructional changes to it. This head consists of a stationary housing 1 with a shaft 3, hollow in part and resting on bearings. A mounting 5 is fixed on rolling bearings 6 in the housing 1. The examined magnetic liquid seal consists of two pole shoes 9, 10, permanent magnets 11, multi-edge sleeve (8 sealing edges) mounted on the shaft 3 and magnetic

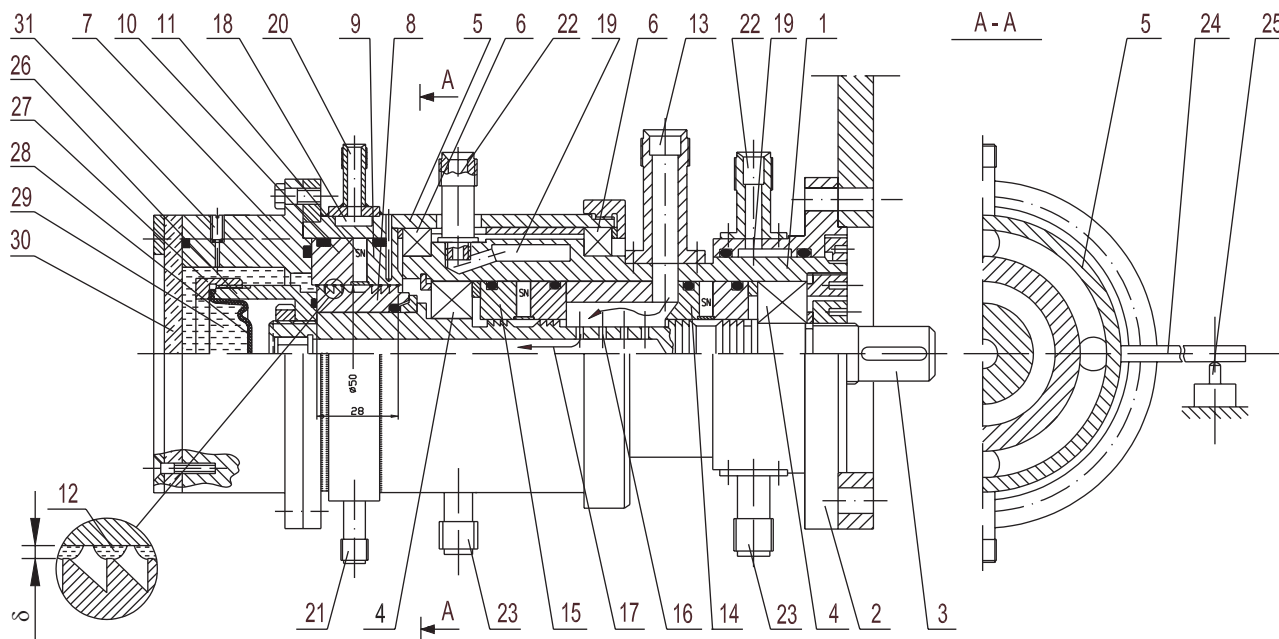

Fig. 1. Measuring head adapted to examine magnetic liquid seals in liquid environment. Numbers in figure indicate :
1 – housing; 2 – flange; 3 – shaft; 4, 6 – rolling bearings; 5 – mounting; 7 – cover; 8 – removable multi-edge sleeve; 9, 10 – pole shoes;
11 – permanent magnet; 12 – magnetic liquid; 13 – supply terminal; 14, 15 – auxiliary ferromagnetic seal; 16 – lateral opening;
17 – longitudinal opening; 18, 19 – cooling chambers; 20, 22 – inlet terminals; 21, 23 – outlet terminals; 24 – lever; 25 – force sensor; 26 – distance sleeve;
27 – clamping ring; 28 – elastomer membrane; 29 – chamber with working (sealed) liquid; 30 – screen; 31 – opening for working liquid dosage.

liquid 12 filling the radial gaps δ between sleeve projections and pole shoes. At the end of the shaft 3 a distance sleeve 26 is mounted, to which an elastomer membrane 28 is fixed using a clamping ring 27. The membrane 28 separates the working (sealed) liquid, which fills the chamber created by the examined magnetic liquid seal, cover 7, distance sleeve 26, screen 30 and membrane 28, from the gas supplied from outside to the hollow in the shaft 3 via terminal 13.

During the measurement of the „burst pressure” in the magnetic liquid seal the gas is supplied under pressure to the shaft hollow and exerts pressure on the sealed liquid via the elastic membrane. When the seal is tight, there is a balance between the pressures created by the liquid and the gas. These pressures can be measured using relevant measuring instruments (precise pressure sensors, or conventional manometers). When the examined seal is broken, the pressure of the sealed liquid in the chamber drops and this drop is recorded by the pressure sensor. The pressure level at which the loss of tightness is observed bears the name of „burst pressure” of the magnetic liquid seal.

Fig. 2 shows the system that supplies the measuring head with the compressed gas (air) and measures the pressure in the examination chamber. The system consists of the compressed air tank 32, air supply conduit 33, cut-off valve 34, and pressure control manometer 35.

For research purposes reported here a simplified measuring system was used which made it possible to observe the phenomenon of tightness loss in the sealing system.

The construction of the measuring head and the methodology of research conduction are the subject of patent application.

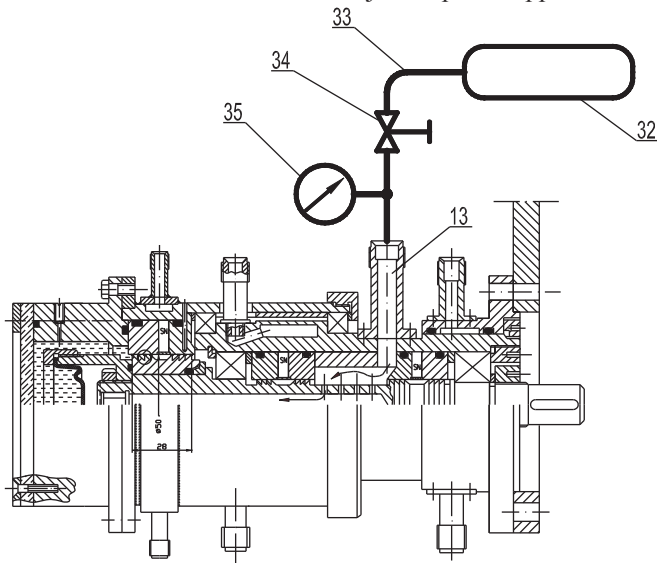

Fig. 2. Measuring head supply with compressed gas (air) and pressure measurement in the examination chamber. Numbers in figure indicate : 13 – supply terminal, 32 – compressed air tank, 33 – air supply conduit, 34 – cut-off valve, 35 – pressure control manometer.

MAGNETIC MATERIALS USED IN EXAMINATION AND EXAMINATION PARAMETERS

The examination was carried out using one type of magnetic liquid, bearing the symbol of C2-40M and delivered by SKTB Polyus, Russia. Table 1 below gives the characteristics of this liquid.

The magnetic field in the sealing system was generated using permanent magnets in the form of discs of the dimensions $\phi 16 \times 5$ mm, sintered from samarium–cobalt mixture. Table 2 below gives the characteristics of the permanent magnets used in the examination.

Table 1. Parameters of magnetic liquid used in the examination.

Basic liquid	Silicon liquid
Magnetic particles	Magnetite Fe_3O_4
Volume concentration of magnetic particles %	11
Density ρ [g/ml]	1.414
Saturation magnetisation M_s [kA/m]	39.1
Plastic viscosity at temperature 20°C, η_{pl} [Pa/s]	0.520
Dynamic viscosity of basic liquid at temperature 20°C, η [Pa/s]	0.043

Table 2. Parameters of permanent magnets used in the examination.

Magnetic material	Sm-Co
Residual magnetic induction B_r [T]	0.77
Coercive force H_c [kA/m]	540
Maximum magnetic field energy density $(BH)_{max}$ [kJ/m ³]	55

GEOMETRY OF EXAMINED SEALS AND EXAMINATION PARAMETERS

The examined seal consists of permanent magnets, two pole shoes stationarily mounted in the head housing, and replaceable, multi-edge sleeve mounted on the rotating shaft. On the outer surfaces of the sleeve a number of sealing projections are machined. These projections have trapezoidal shape in the cross-section and are situated symmetrically with respect to the medial of the cylindrical surface of the sleeve.

In the examination one sleeve was used with the number of sealing projections: $Z = 8$, and radial gap : $\delta = 0.1$ mm. The nominal diameter of the sealed opening was : $d = 50$ mm. The tests were performed for the following rotational speeds : $n = 125, 250, 500, 750, 1000, 1500, 2000, 3000$ rev/min. Moreover, one test was performed for continuous, gradual increase of rotational speed until the sealing system lost its tightness. All tests were performed at the set compressed air pressure equal to: $p = 0.15$ MPa.

EXAMINATION PROCEDURE

A number of permanent magnets 11 were mounted in the measuring head housing between the pole shoes 10 (Fig. 1). The magnets, having the shape of discs, were distributed uniformly along the circumference. Then the sleeve with sealing projections 8 was drawn over the shaft, and, during this operation, the gaps were gradually filled with the examined magnetic liquid, in a volume $V_0 = 100\mu\text{l}$ per each sealing projection. The magnetic liquid was dosed using a precise laboratory feeder of MINILAB 100 type.

When the assembly was completed, excessive volume of the magnetic liquid was removed from the seal and the membrane 28 was mounted to separate the space filled with the liquid from the area in which the pressure is generated by the compressed gas action. After checking the tightness of the pressure generation system, the research chamber was mounted

on the measuring head and fixed with bolts to the head housing. Finally it was filled with the usable water.

The air from the tank 32 (Fig. 2) was supplied to the gas space via conduit 33, terminal 13 and openings 16, gradually increasing the pressure to the required level of 0.15 MPa. When the required pressure was reached and the tightness of the system was checked, the cut-off valve 34 was closed. This way a small volume was obtained in which the pressure was built up by the compressed air. Thanks to it the time when the magnetic liquid seal loses its tightness can be precisely determined from observation of the air pressure drop recorded on the manometer 35. The propulsion motor was started and when the required revolutions were obtained, the 8-hour examination cycle, identical for all tests, began. Due to preliminary nature of the research and the necessity of observation of the system in operation, the compressed air pressure in the examined system was not recorded.

RESULTS OF EXAMINATION

In total, eight eight-hour test cycles were executed for different steady-state rotational speeds. Moreover, one test cycle was executed during which the rotational speed was continuously and gradually increased up to the propulsion system limit, $n = 12000$ rev/min. Results of these tests are shown in Table 3.

Table 3. Results of examination of a magnetic liquid seal working in liquid environment. Sealed agent : usable water. Sealing sleeve: 8 projections, gap height 0.1 mm. Magnetic liquid: C2-40M based on silicon liquid.

No. of test	1	2	3	4	5	6	7	8	9
Shaft revolutions [rev/min]	125	250	500	750	1000	1500	2000	3000	0 to 6800
Time duration [h]	8	8	8	8	8	8	8	8	About 0.3
Starting pressure [MPa]	0.150	0.150	0.150	0.150	0.150	0.150	0.150	0.150	0.150
Final pressure [MPa]	0.152	0.153	0.153	0.156	0.158	0.167	0.172	0.181	About 0.09: loss of tightness

Test 9 was carried out for gradually increasing rotational speed.

The frequency converter (inverter) that controls the revolutions of the propulsion system was set for gradual increase of rotational speed until maximum revolutions $n = 12000$ rev/min were reached in 30 minutes. During the test, after about 18 minutes from the start, at the rotational speed approximately equal to $n = 6800$ rev/min gradual, but clearly visible pressure decrease was recorded in the compressed air space and traces of leakage through the magnetic liquid seal were observed.

For the shaft diameter $d = 50$ mm, the rotational speed $n = 12000$ rev/min corresponds to the linear velocity equal to 31.4 m/s. After recalculating this velocity to the rotational speed of a propeller with the seal diameter equal to $d = 250$ mm we obtain 2400 rev/min i.e. the optimum speed for a 10 propeller. The scaling principle is not precisely valid here, but with high probability one can expect that laboratory tests of the seal with 250 mm diameter will confirm this result. Further tests are planned with changed sealing agent, for longer time durations and higher linear velocities.

EXAMINED MAGNETIC MATERIALS AND PARAMETERS OF TEST 9

The test was carried out using one type of magnetic liquid bearing the symbol of C2-40M and delivered by SKTB Polyus, Russia. Table 5 below gives the characteristics of this liquid:

Table 5. Parameters of magnetic liquid used in test 9.

Basic liquid	Silicon liquid
Magnetic particles	Magnetite Fe_3O_4
Volumetric concentration of magnetic particles %	11
Density ρ [g/ml]	1.414
Saturation magnetisation M_s [kA/m]	39.1
Plastic viscosity at temperature 20°C, η_{pl} [Pa/s]	0.520
Dynamic viscosity of basic liquid at temperature. 20°C, η [Pa/s]	0.043

The magnetic field in the sealing system was generated using permanent magnets having the shape of a discs, of the dimension $\phi 16 \times 5$ mm, which were sintered from samarium–cobalt mixture. Table 6 below gives the characteristics of the permanent magnets used in test 9.

Table 6. Parameters of permanent magnets used in test 9.

Magnetic material	Sm-Co
Residual magnetic induction B_r [T]	0.77
Coercive force H_c [kA/m]	540
Maximum magnetic field energy density $(BH)_{max}$ [kJ/m³]	55

Fig. 3 below shows the friction torque as a function of temperature of the warming liquid. A noticeable tendency here is drag decrease during seal's operation. The examination was carried out for the pressure p between the air and the nitrogen equal to 1 Mpa.

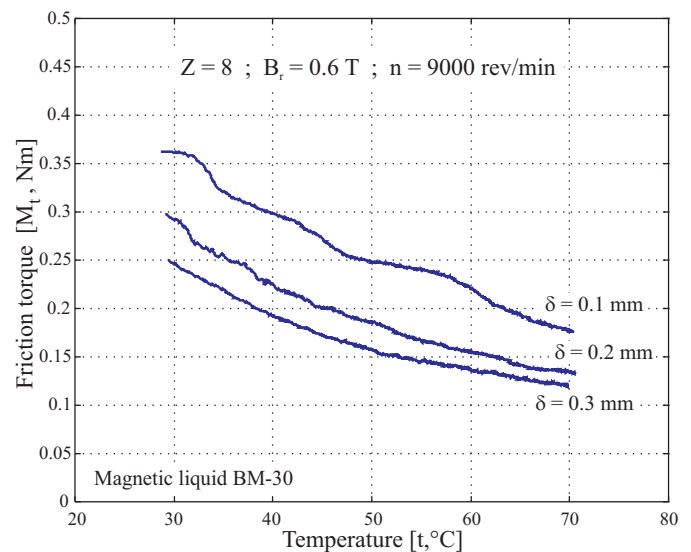

Fig. 3. Friction torque M_t vs. temperature t recorded during examination of the magnetic liquid seal BM-30. $Z = 8$, $B_r = 0.6$ T, $\delta = 0.1 ; 0.2 ; 0.3$ mm, $n = 9000$ rev/min.

Fig. 4 shows the burst pressure for the parameters taken from Fig. 3.

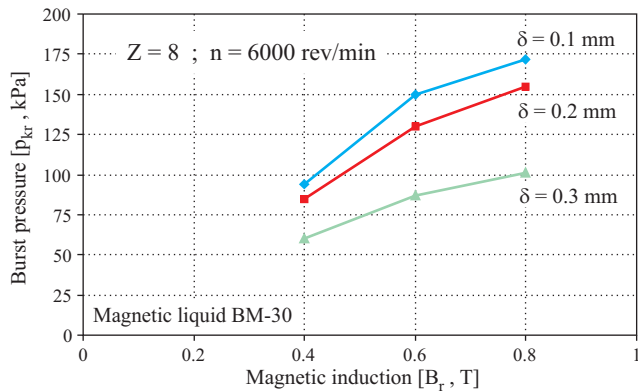

Fig. 4. Burst pressure p_{kr} vs. magnetic induction B_r in the magnetic liquid seal BM-30. $Z = 8$, $\delta = 0.1 ; 0.2 ; 0.3$ mm, $n = 6000$ rev/min.

CONCLUSIONS

- In the reported examination, all test cycles were executed without changing magnetic liquid in the seal. Therefore it can be assumed as first approximation that the durability of the seal in operating conditions in the usable water environment was equal to 64 hours, the least.
- The loss of seal's tightness observed in the last test resulted most likely from both high dynamics of motion at the interface between the sealing phase (magnetic liquid) and the sealed phase (usable water under pressure), and possible fatigue of the magnetic liquid, accumulating during previous tests.
- It is noteworthy that the examination was carried out in the conditions of direct action of the entire volume of the liquid on the examined seal. However, in known descriptions of technical solutions and research works hybrid sealing systems are often used, for instance a double system consisting of a preliminary front-type seal and a final

magnetic liquid seal, which secures absolute tightness. The task of the preliminary seal in this case is to limit the volume of the liquid that comes into contact with the magnetic liquid in the final seal.

- The reported tests allow a conclusion to be formulated that the research rig has a correct construction and provides opportunities for obtaining assumed research goals. Further constructional modifications of the research rig are suggested to allow more complex sealing systems to be examined.
- The obtained preliminary results of seal examination are so promising that they justify continuation of research activities oriented on examining magnetic liquid seals designed to operate in the liquid environment.
- High efficiency and dynamics of electric drive systems used on watercraft resulted in their increased proportion in total number of propulsion applications. As recently as a few years ago the development in the field of magnetic materials, ferrofluid liquids, non-linear control techniques and hydrodynamics reached a level providing opportunities for effective introduction of ring-type propulsion systems on a large scale.

NOMENCLATURE

Z - number of sealing projections
 d - diameter
 n - rotational speeds
 p - pressure
 V_0 - volume
 δ - radial gaps

BIBLIOGRAPHY

1. Ochoński W., Szydło Z., Zachara B.: *Burst Pressure of Magnetic Fluid Rotary Shafts Seals* (in Polish). *Zagadnienia Eksploatacji Maszyn*, 2000 Vol. 35, No. 3, pp. 145-156
2. Szydło Z., Zachara B., Ochoński W.: *Ferromagnetic fluids and their application in mechanical designs* (in Polish). Proc. of 1st Conference on Automation of Machines, Devices and Processes APRO'99, 1999 pp.411-418

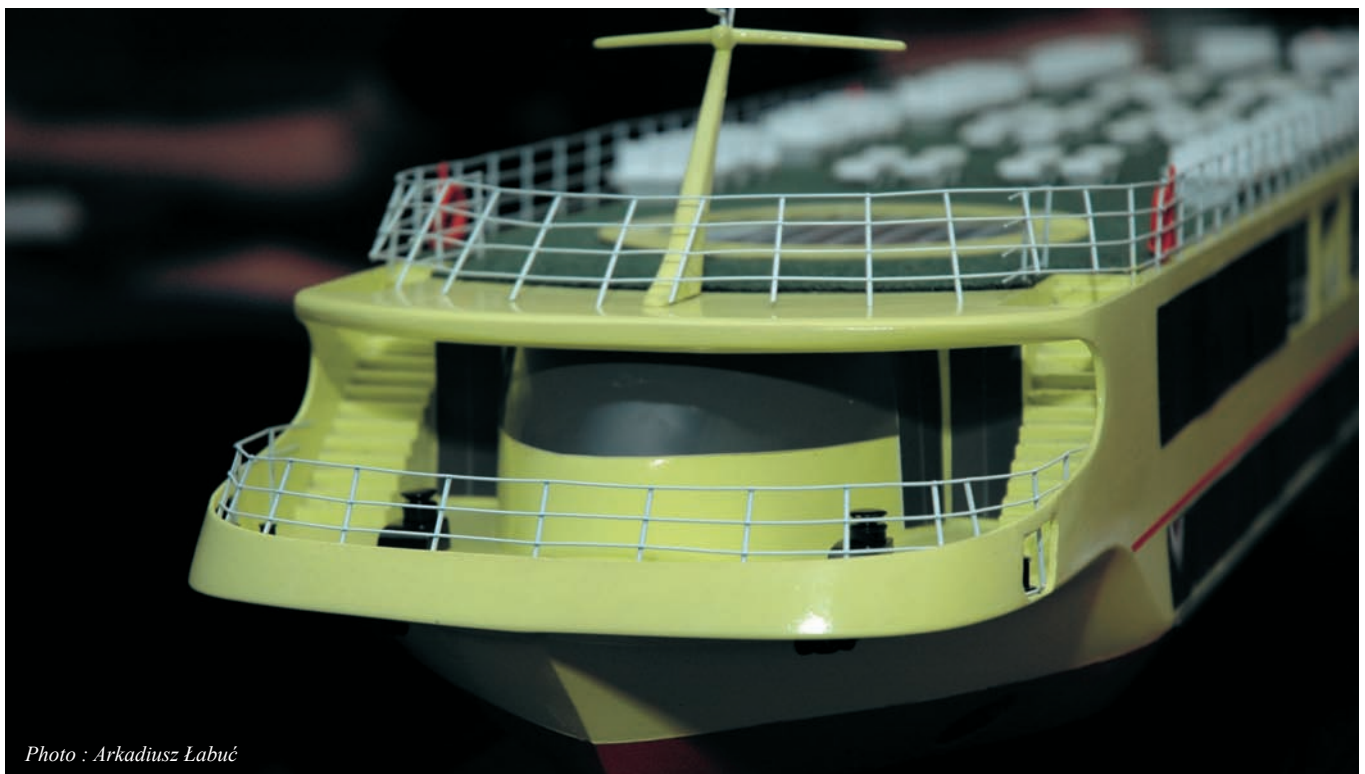

Photo : Arkadiusz Łabuć