

SELECTED ISSUES OF HYBRID OUTBOARD MOTORS

Wojciech Leśniewski

Gdańsk University of Technology, Poland

ABSTRACT

The aim of the research reported in the article was designing a hybrid drive system based on an outboard internal combustion engine offered by a selected producer and testing its operating characteristics. The article presents different designs of this type of drive which can be found in the literature and are available in the market. The designed hybrid outboard drive system was tested both on the laboratory test rig and in real operating conditions. The results of these tests are included.

Keywords: boat drive, outboard motors, hybrid drive, emission-free drive, electric drive

IDEA OF HYBRID OUTBOARD DRIVE

Enormous progress in technology and attempts to increase the operating efficiency of drive systems are the reasons why watercraft drives with electric motors gain in interest and popularity. On some boats, where possible, a conventional internal combustion drive can be fully replaced by electric drive, while for the watercraft on which the nature and potential of operation require leaving the internal combustion engine, a hybrid system seems the most suitable solution. As long as typical stationary drive systems are concerned, the matter seems trivial. The electric motor is very often mounted at the shaft axis or parallel to it, depending on the type of hybrid system to be installed: parallel or serial, and how much place is available for system expansion. However, in the case of boats with outboard motors, the hybridisation problem becomes more complex. While a serial hybrid system enables using a power generator with a set of batteries and an electric outboard propeller, a parallel system requires a special design of the outboard motor. Possible solutions based on two independent drives: electric and with internal combustion engine, should be excluded and the searched hybrid system should have a shared propeller, as otherwise,

the system could only act as two independent drives, with no profits resulting from hybridisation.

GENESIS OF THE PROJECT

Since 2006, the author of the article was a member of a team of research workers and students of Gdansk University of Technology involved in building and testing the operation of solar energy fed watercrafts. Actively participating for over 10 years in international racings and other events related with unconventional methods of watercraft feeding, the author had an opportunity to observe a huge development in available technologies. Miniaturisation of control systems, increase in power density of electric motors, and improvement in operational safety of newest battery types are the reason why the electric drive is becoming more and more available and cheaper in both installation and operation terms.

A research project which provided opportunities to learn about principles and conditions of operation of hybrid drive systems was related with designing a drive system for watercraft intended to operate in the Zulawy Loop [1]. Within the framework of this project, a special test rig was

built, along with a complete drive system based on 100 kW Diesel engine and 15 kW electric motor. The tests of this drive system, performed in conditions close to its real operation, have made it possible to study its behaviour in given operating conditions. Considerations on possible concepts of hybrid systems were the motivation for searching for solutions applicable on boats on which the use of a stationary drive was not possible.

EXISTING DESIGNS OF OUTBOARD DRIVES

Despite the existence of a number of patents, hybrid drives are not available in the market. However, at a time of increasing focus on improving the drive efficiency, and concern about the purity of exhaust gas leaving the boat drive engine, the need for designing and production of hybrid systems for small boats with outboard drives seems inevitable. An internal combustion engine offers great opportunities concerning the navigation range and power of the given watercraft, while the electric drive is quiet and does not emit exhaust gases. Unfortunately, installing large batteries is very expensive and takes much more space than a fuel tank needed for feeding conventional drive systems with internal combustion engines. That is why full elimination of internal combustion drive is not always possible, and in those cases a combination of both drive types is necessary. A hybrid drive system should be simple in maintenance and should expand the range of operation of the conventional drive system.

Installing an additional electric module involves some new requirements. The watercraft with this drive should be more versatile in terms of accessible water areas and navigation

restrictions. Current patents, which have been developed in recent years, offer different concepts of hybrid drive systems. They are based on new designs of complete drives or very complex modifications of existing ones (Fig. 1).

In the designs published in the literature, the electric motor is placed under the internal combustion engine and in this case these two systems drive a shared vertical shaft, or the electric motor is installed in the propeller base casing and drives the propeller shaft. Another, simpler method of installing an additional electric drive is shown in Fig. 2 and consists in mounting the electric system with a separate propeller on the anti-cavitation plate. This case is considered a combination of two independent systems, and its only advantage is the possibility to navigate using an electric drive, while the remaining advantages resulting from the use of a hybrid system are lost. In general, the solutions proposed in the literature do not include concepts of modernisation of existing drives owned by boat users or offered for sale.

MODERNISATION CONCEPT OF EXISTING DRIVE

The existing patents and designs of hybrid outboard drives assume that a completely new drive system will be built. However, drive hybridisation refers not only to newly built systems, but also to those offered in the market or already used on boats. The replacement of these systems is usually unnecessary and unjustified from the economic and ecological point of view. For those cases, a solution which turned out most suitable after performing numerous tests and analyses is a concept of an additional module hybridising the existing outboard drive (Fig. 3).

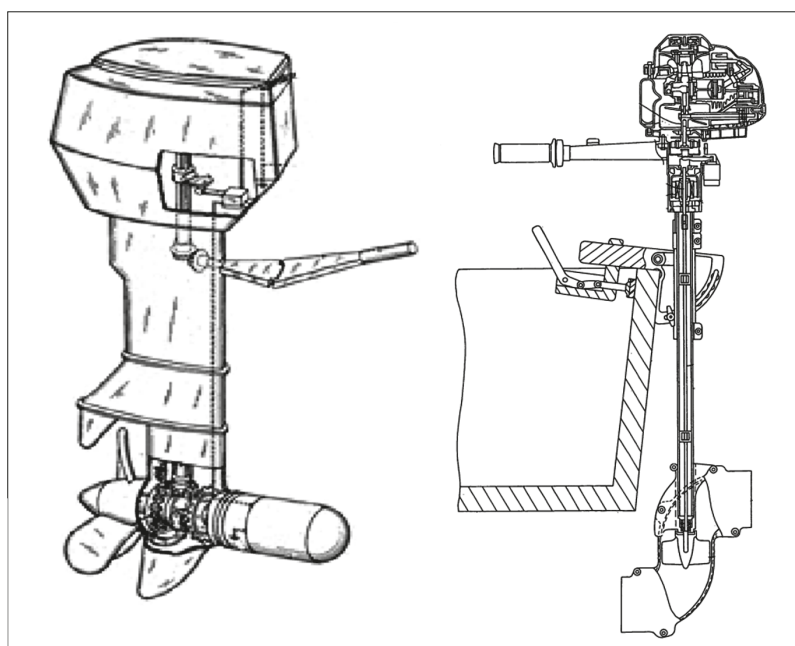

Fig. 1. Different solutions of outboard drives: electric motor mounted at the propeller shaft axis (left); electric motor mounted at the vertical shaft axis, under the internal combustion engine (right) [2],[3]

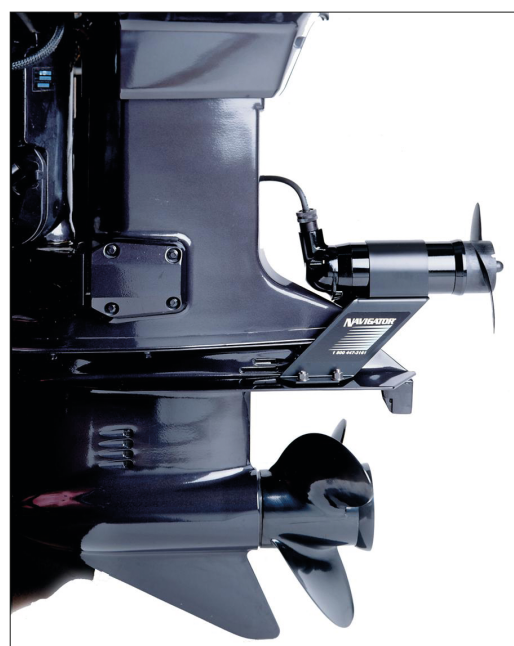

Fig. 2. Electric motor installed on anti-cavitation plate

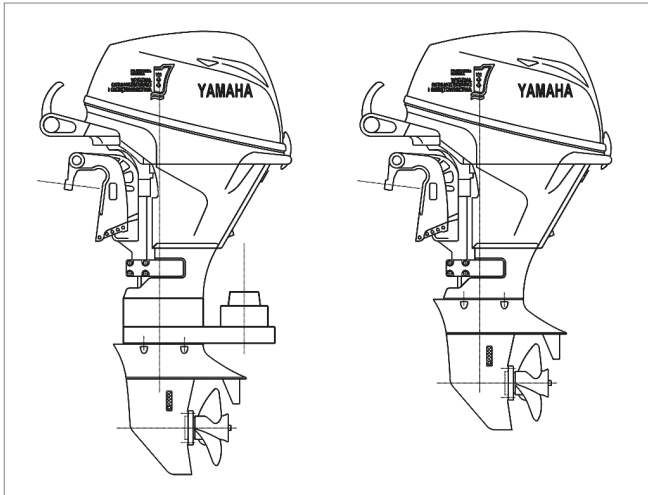

Fig. 3. Hybrid outboard drive (left) and drive before modernisation (right)



Fig. 4. Electric module installed on the outboard motor base

There are some important factors which affect the selection of a proper place for delivering additional power to the propeller shaft. The currently built outboard drives are frequently based on similar elements for a given type series of propellers, which makes it possible to use one electric system for all these propellers.

The engine selected for design and test purposes was 15 KM YAMAHA F15CES with short base, the outboard engine of a leading producer which has some margin of permissible power transmitted to the bevel gear. A 20 KM engine of the same type is also offered for sale. Before modification, the engine was expected to work faultlessly during the performed tests and generate no errors and doubtful data. The engine is equipped with a reversing reduction gear with ratio of 2.08:1, mounted in the column base. When using an electric motor for driving, it is noteworthy that the amount of energy stored in the battery is limited. The electric motor used for expanding the drive system was an air cooled 3 kW DC motor. This motor was also used by the author in other projects, which made it possible to assess the effect of configuration of the drive system on its operation. The electric motor was installed above the propeller base division plane (Fig. 4) and connected to the vertical shaft via a belt transmission. During the operation of the electric drive, the water pump and the upper part of the vertical shaft are inactive. A one-way clutch was used to disconnect the internal combustion part when the electric system was active. For this purpose, the original shaft, available in producer's service as a replaceable element, had to be modernised.

The electrical energy in the battery is very valuable, as the batteries are most expensive components when investing in electric drive. Their capacity affects directly the time of watercraft operation in electric mode. Considering the amount of stored energy, the drive system should be designed and modified in such a way that its total efficiency is as high as possible. When designing the electric system, all mechanisms which do not participate in its operation should be disconnected. This mostly refers to the internal combustion engine crankshaft and the cooling water pump.

The electric motor has much smaller power, therefore its rotational speed should be properly adjusted when driving the same propeller as the internal combustion engine. Propellers for drive systems with internal combustion engines are selected such that the engine can reach its nominal rotational speed. In this situation, the belt transmission ratio for the electric motor should be selected in such a way that both drives can work at their nominal powers and rotational speeds, thus ensuring long lasting and faultless operation of the hybrid drive.

TEST RIG

Modifying an outboard motor involves some new requirements and limitations. The drive system intended for use on watercraft should undergo a very thorough inspection and testing. Of high importance is maintaining relevant reliability of the modified motor. If the object of modification is a brand-new engine, its modification may cause loss of manufacturer's warranty, therefore the introduced modifications should receive approval from the engine producer. First of all, they should not affect the correctness of operation of internal combustion engine components, which is a precondition for maintaining warranty for unmodified parts. The remaining components should be manufactured with utmost accuracy to ensure proper operation of the system.

The test rig was designed and manufactured in such a way as to provide opportunities for measuring operating parameters of the hybrid system in the entire range of electric motor operation. A complete motor was mounted on a specially prepared frame and connected to a hydraulic pump via flexible couplings and torque meter (Fig. 5). The hydraulic oil pressure in the pump circuit was controlled using a throttling valve, which made it possible to adjust the torque and rotational speed to nominal operating parameters of the electric motor.

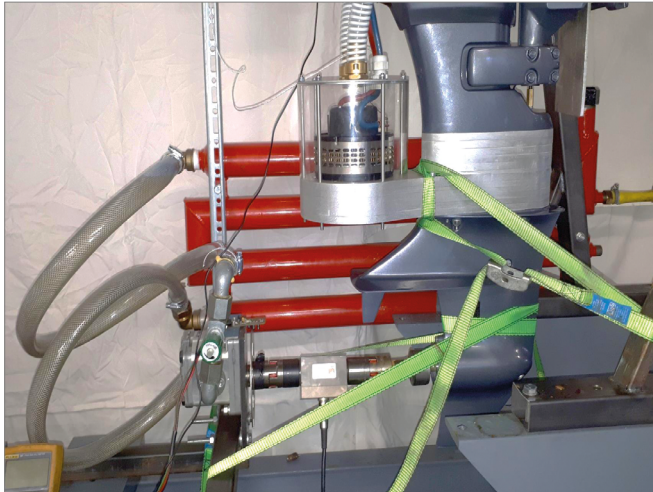

Fig. 5. Hybrid outboard drive on test rig

Changing the rotational speed of the electric motor simultaneously adjusted the motor load. This is the situation which also occurs during a real operation of the outboard motor. The parameters recorded during the tests included: rotational speed, propeller shaft torque, voltage and current delivered to the complete system (including measuring systems for batteries and the cooling system for electric motor). The measuring system used for recording mechanical power consisted of a torque meter with measuring range of 0–20 Nm, and an in-house optical sensor of rotational speed which generated one voltage pulse per one shaft revolution. This system also included terminals for measuring the voltage supplied to the controller and the current transformer LEM LAH 100-P 100A / 50mA used for measuring the current in the supply cable to the controller. The recorded parameters were used for calculating electric and mechanical power of the drive system without propeller.

RESULTS OF MEASUREMENTS AND THEIR DISCUSSION

The nominal point of system operation was defined by the settings at which the motor consumed 75 A current at 48 V voltage. These values were specified by the producer as nominal operating parameters. For those settings the motor reached the rotational speed of 41,22 rps on propeller shaft. The remaining operating points were obtained by reducing rotational speed via changing the setting of the hydraulic pump throttling valve. The characteristics obtained in this way are shown in Fig. 6 and Fig. 7. For each point of electric motor operation, the temperature was measured until thermal equilibrium was reached. During the operation, the motor was heated up to 65°C in time depending on the applied load. The intensity of electric motor air cooling depended only on the current speed, as the air exchange in the motor casing did not depend on the applied load. The obtained maximum total efficiency of the electric drive without propeller was equal to 67%.

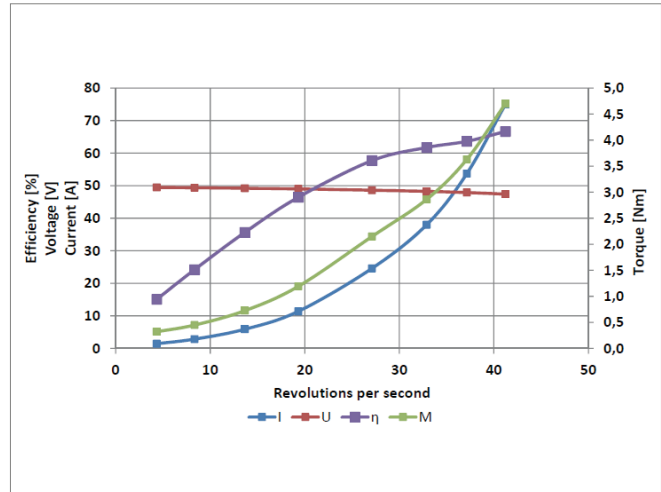

Fig. 6. Experimentally recorded operating parameters and efficiency of hybrid outboard drive system working in electric mode

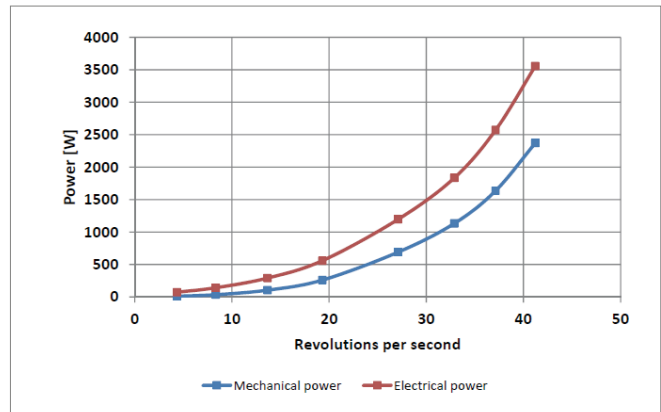

Fig. 6. Mechanical and electric power calculated from experimentally recorded operating parameters of hybrid outboard drive system working in electric mode

According to the data delivered by the producer, the maximum efficiency of the selected electric motor is 88%. However, in the examined drive system, a number of additional power loss sources can be named, such as the bevel gear, for instance, which is adapted to operate at power nearly three times as high as that delivered in electric mode. When designing the electric system, sealing of the vertical shaft and belt transmission at a number of additional points was assumed. The electric power measurement referred to the entire drive system, therefore losses generated in cables, controller, and the electric motor cooling system (with two blowers) had also to be taken into consideration. Each of these elements is a potential source of losses and affects the total system operation efficiency. Taking account of these additional power loss sources, the total efficiency of the drive system without propeller should range within 60–70%, which were the values obtained from the tests.

CONCLUSIONS

In present days, increasing the use of hybrid drive systems on watercraft and in widely understood sea transport seems imminent. Hybrid systems offer many possibilities. The use of a hybrid system with one propeller enables parallel operation of both drives, or only sole operation of one (electric) drive. Moreover, it makes it possible to additionally load the internal combustion engine, which its advantage over conventional systems. As a rule, the internal combustion engine can work effectively when its load exceeds 60% of nominal load. Therefore, when its basic load drops below that level, it is profitable to additionally load the engine with the electric motor, thus recovering part of energy and improving total efficiency of the system. The recovered energy can be stored in batteries and then used for supplying the electric drive. This issue will be studied at the next stage of the research of the presented hybrid drive system.

Electric motors used in hybrid drives of boats usually reach about 30% of power of the main drive, which usually is the internal combustion engine. This proportion is justified economically. The electric motor allows the boat to sail with smaller resistance and does not require installation of large batteries. One hour of operation of the 3-kW electric motor used in the tested drive system required installation of about 25 kg of modern lithium batteries, which is equivalent in volume with a portable fuel tank used for outboard engines. Boats which seem ideal for this type of drive are so-called houseboats, which usually make use of engines with long base. The use of hybrid drive on those boats (Fig. 8) allows them to enter water areas on which the watercraft with zero emission is only allowed to sail.

The tests with the designed hybrid motor, performed on the laboratory test rig, confirmed the correctness of the adopted design assumptions. Optimal parameters of electric motor cooling were properly selected, and the efficiency of its operation was checked. In field conditions, the system underwent leakage tests and other measurements which allowed to determine parameters of cooperation of electric motor with internal engine.

A significant conclusion from the performed test is the existence of three states of operation of the hybrid system, which are characterised by different rotational speeds of electric motor. The motor can work parallel with the internal combustion engine at engine's rotational speed, or, after switching the engine off, decrease the rotational speed of the propeller to adapt it to the power available in this configuration. This rotational speed depends on the propeller characteristic and in the examined case, was about twice as low as that of the internal combustion engine.

REFERENCES

1. J. Kowalski, W. Leśniewski, and W. Litwin, "Multi-source supplied parallel hybrid propulsion of the inland passenger ship STA.H. Research work on energy efficiency of a hybrid propulsion system operating in the electric motor drive mode," *Polish Maritime Res.*, vol. 20, pp. 20–27, 2013.
2. Rodolfo Rodriguez Balaguer, Patent *Outboard motor unit*, US3703642A 1971-10-28.
3. Hiroyuki Kitani, Kazumi Miyashita, Shigeo Terada, Tadafumi Hirose, Patent: *Outboard motor* US20060025025A1 2004-07-28.
4. <https://www.boatownersworld.com/navigator-35-electric-boat-motor-35lb-thrust-sku-653501-stainless-steel.html> 20.10.2018.

CONTACT WITH THE AUTHORS

Wojciech Leśniewski

e-mail: wojciech.lesniewski@pg.edu.pl

Gdańsk University of Technology
Narutowicza 11/12, 80-233 Gdańsk
POLAND