



## SIMPLY AND LOW COAST ELECTROMYOGRAPHY SIGNAL AMPLIFIER

Robert BARAŃSKI\*, Anna GRZECZKA\*\*

\*AGH University of Science and Technology, Faculty of Mechanical Engineering and Robotics  
Adama Mickiewicza 30, 30-059 Kraków, Poland, e-mail: [robertb@agh.edu.pl](mailto:robertb@agh.edu.pl)

\*\* Gdańsk University of Technology, Faculty of Mechanical Engineering  
Narutowicza 11/12, 80-233 Gdańsk, Poland, e-mail: [annagrzeczka@gmail.com](mailto:annagrzeczka@gmail.com)

### Abstract

Recently, there has been a noticeable increase in interest in solutions utilizing electrical signals accompanying muscle activity. Electromyography (EMG) is a technique for recording, analysis and evaluating the electrical activity produced by striated muscle. Its great popularity is due, among other, to the ability to measure with non-invasive electrodes (called as sEMG surface electromyography). However, the limitations of this method are the high costs of specialized measuring equipment, and in particular the systems of bioelectric signal preamplifier circuits.

The work presents the design of a low budget EMG signal amplifier. It has been designed and validated in accordance with ISEK (International Society of Electrophysiology and Kinesiology) and SENIAM (Surface ElectroMyoGraphy for Non-Invasive Assessment of Muscles).

Keywords: EMG amplifier, Electromyography amplifier, bioelectric amplifier

### NISKOBUŻETOWY WZMACNIACZ SYGNAŁU ELEKTROMIOGRAFICZNEGO

#### Streszczenie

W ostatnim czasie zauważalny jest znaczny wzrost zainteresowań rozwiązaniami wykorzystującymi sygnały elektryczne towarzyszące aktywności mięśni. Za rejestrację zmian potencjałów mięśniowych, ich rejestrację oraz analizę odpowiada technika zwana elektromiografią (EMG). Jej duża popularność wynika m.in. z możliwości pomiarów z użyciem nieinwazyjnych elektrod (czasami nazywana elektromiografią powierzchniową sEMG). Ograniczenie stanowią jednak wysokie koszty specjalistycznej aparatury pomiarowej, a w szczególności układów przedwzmacniaczy sygnałów bioelektrycznych.

Praca przedstawia projekt nisko budżetowego wzmacniacza sygnałów EMG. Został on zaprojektowany i zwalidowany zgodnie z wytycznymi ISEK (International Society of Electrophysiology and Kinesiology) oraz SENIAM (Surface ElectroMyoGraphy for the Non-Invasive Assessment of Muscles).

Słowa kluczowe: wzmacniacz EMG, wzmacniacz elektromiograficzny, wzmacniacz sygnału bioelektrycznego

## 1. INTRODUCTION

Electromyography (EMG) is a diagnostic test that provides information on functional status of muscles and is part of electrodiagnosis (EDX). EMG consists in recording the electric activity of the striated muscles. This activity is related to the ability to penetrate sodium and potassium ions through the cell membrane. Due to the uneven distribution of these ions within the muscle cell, the electrical charge of the interior of the cell relative to the cell membrane is polarized. The polarization potential, at a standstill of about 80mV, changes with the functional condition of the muscle. Voltage changes observed in a healthy muscle with low effort usually lasts 2 to 15 ms and contains 2-3 phases. The amplitude of the normal signal during muscle activity is small, ranging from 0.2 to 3 mV and the frequency is below 500 Hz.

In medicine, in the diagnosis of muscle disease are used elementary electromyography (needle) and

surface electromyography (sEMG). The first one makes it possible to classify myogenic or neurogenic disease. The second is exploring the extent of the disease in muscle groups, symmetry, or asymmetry of EMG recording, the interaction between different muscle groups, muscle tone. In electromyography, the needle electrodes are used to collect the electrical signal. This technique is probably more sensitive than sEMG, so it works well in cases of initial signs of pathology in muscle. However, it requires sterile laboratory tests. Non-invasive and therefore much easier and faster to use is the surface electromyography, which, by applying the pre-prepared skin to the electrodes (two active and one reference electrode), records the biopotential of the muscle activity or the muscle group located shallow beneath the skin of the patient. Significant from the diagnostic point of view are measurements of the duration of subsequent phases of muscle activity, the shape of the signal, and its amplitude [1, 2].

Surface electromyography was initially applied in occupational medicine, where it is still fairly easy to use today to assess the load and fatigue of the musculoskeletal system. The process of muscle fatigue causes an increase in the amplitude of the functional potentials of the stimulated motor units describing the electromyographic recording and the shift of the power spectrum towards the lower frequencies.

Further studies have shown a correlation between the amplitude of the EMG signal and the force developed during muscle contraction, and this has also affected the use of electromyographic examination in sport. With this measurement, you can get the biomechanics needed to assess both the fitness and training levels of the athlete, and thus improve the learning process for beginners in sport, to help you recover from injury, and to control advanced athlete skills. Research is underway on sprinters, ski jumpers, basketball jumpers [2] and also by authors in the area of kitesurfing [3].

## 2. EMG SIGNAL AMPLIFIER

The ability and quality of biopotential recording depends to a great extent on the parameters of the amplifiers used in the measuring system. The bioelectric amplifier consists of several single input, main and output amplifiers, as well as filters, power supply, calibrator, ohmmeter and control circuits. The most important part of the bioelectric voltage amplifier is a high-quality input-input amplifier that receives very weak signals from the human body in the presence of strong interference, without affecting the value and shape of the measured signal. It strengthens weak differential voltages in the presence of strong common voltages. The input amplifier converts the voltage difference between the two electrodes (differential input voltage) into a single amplified output voltage. When both electrodes are active (located in the presence of bioelectric signals), then this type of measurement is called bipolar. If one of the electrodes is passive, i.e. placed in an electrically neutral position, the measurement is called monopolar. Differential voltage from electrodes of the order of microvolts simultaneously occurs with a common signal, i.e. a disturbance signal, of the value of hundreds of millivolts. This interfering signal is a voltage of 50 Hz, which is the voltage that interferes with the power grid. The tested person is for these voltages an electric antenna, by the capacitance between it and the electrical grid and ground. These capacities range from several to several hundred picofarads. In order to correct any asymmetry of the measuring amplifiers that are in production, extremely precise lasers are used, therefore the price of the measuring amplifiers is very high [4, 5].

Another very important parameter of each amplifier is its input resistance. The resistance of properly installed electrodes, i.e. electrode-skin

contact, ranges from several hundred to several thousand ohms. The resistance of the electrodes creates a voltage divider with an input resistance of the amplifier, causing the measured bioelectric voltage to weaken. In addition, with the frequently occurring asymmetry of the electrode-to-body contact resistance at both inputs of the amplifier, an additional differential noise signal appears at its input. Therefore, the input resistance of each input of the amplifier should be equal to and much higher than the resistance of the electrodes. In practice they should be at least tens of millions of ohms. Connections cables are very important, which can create additional capacities, reducing the quality of measurement.

Another important feature of the amplifier is the value of input noise, that is, the difference in the input of the amplifier, expressed in microvolts. The value of this noise mainly depends on the resistance of the electrodes. For a good amplifier it should be about 1 mV.

The bandwidth of the transmitted frequencies by the measuring system including the amplifier is also important. For the EMG signal, the bandwidth is between about 1 and 500 Hz.

An important parameter of the input amplifier is its voltage gain. Theoretically, the greater the gain, the more resistant the signal is. However, in practice a reinforcement is used which produces a constant electrical voltage up to about 200 mV, which is safe in electro-skin contact. Since the input amplifier strengthens the DC voltage, the presence of such a high constant voltage at its input may cause saturation or over-voltage and consequently its blocking.

The next amplifier parameters are the distortion that informs of the change in signal shape after the amplifier goes through and is less than a fraction of a cent.

In some applications, power consumption may also be important, especially for portable devices powered by batteries. In addition, with the decrease in current consumption, some important parameters of the amplifier deteriorate, including CMRR and noise.

Other less important parameters of the amplifier include: internal capacitance, output resistance, phase shift, etc. Design and construction of a bioelectric voltage amplifier meeting the above criteria is a very difficult and costly task. The difficulty is also that the amplifier must be resistant to electrostatic charges that appear on the test subjects and can be as high as several thousand volts. This requires the use of special safety devices [6, 7].

### 2.1 Technical requirements

The guidelines for measuring the electrical activity of muscles are determined by the SENIAM project (Surface ElectroMyoGraphy for the Non-Invasive Assessment of Muscles) [8], which is a



European concerted action in the Biomedical Health and Research Program (BIOMED II) of the European Union.

Parameter	Recommended value or condition
<b><u>Electrodes (bipolar montage)</u></b>	
Electrode size	Diameter < 10 mm
Interelectrode distance (IED)	< 20 mm or ¼ the muscle length, which is smaller
Electrode localization	Between the most distal innervation zone and the distal tendon or between the most proximal innervation zone and the proximal tendon; not over and innervation zone
Reference electrode localization	Wrist, ankle, processus spinosus of C7, or other electrically inactive area
<b><u>Amplifier</u></b>	
High-pass filter (low frequency cut-off): for EMG spectral analysis for movement analysis only	< 10 Hz 10 – 20 Hz
Low-pass filter (high frequency cut-off): for general applications	~500 Hz (sampling frequency > 1000 samples/s)
for special wide band applications	~1000 Hz (sampling frequency > 2000 samples/s)
Input referred voltage noise level	< 1 $\mu V_{RMS}$ (in the 10-500 Hz bandwidth)
Input referred current noise level	< 10 pA <sub>RMS</sub> (in the 10-500 Hz bandwidth)
Input impedance	>100 M $\Omega$ (for the conventional electrodes) >1000 M $\Omega$ (for “dry” pin electrodes)
Gain	suitable to bring the signal into the input range of the A/D converter with desired input resolution
<b><u>Sampler and A/D converter</u></b>	
Sampling frequency	> 1000 samples/s (general applications) > 2000 samples/s (wide band applications)
Number of bits of A/D	12 (requires amplifier with variable gain) 16 (fixed gain amplifier may be used)

The Standards for Reporting EMG Data, written by Roberto Merletti are endorsed by the International Society of Electrophysiology and Kinesiology (ISEK). The standards are also published in the Journal of Electromyography and Kinesiology (JEK) [9].

### **Electrodes:**

Reports on surface recording of EMG should include:

- electrode material (e.g., Ag/AgCl)
- electrode geometry (discs, bars, rectangular)
- size (e.g., diameter, radius, width, length)
- use of gel or paste, alcohol applied to cleanse skin, skin abrasion, shaving of hair, etc.
- interelectrode distance
- electrode location, orientation over muscle with respect to tendons, motor point and fibres direction.

Intramuscular wire electrodes should be described by:

- wire material (e.g., stainless steel)
- if single - or multi-strand
- insulation material
- length of exposed tip
- method of insertion (e.g., hypodermic needle)
- depth of insertion
- if single or bipolar wire
- location of insertion in the muscle
- interelectrode distance
- type of ground electrode used, location.

Needle electrodes and their application should be described and include material, size of conductive contact points at the tip, depth of insertion and accurate location in the muscle.

### **Amplification:**

Amplifiers should be described by the following:

- if single, differential, double differential, etc.
- input impedance
- Common Mode Rejection Ratio (CMRR)
- signal-to-noise ratio
- actual gain range used.

Filtering of the raw EMG should be specified by:

- low and/or high pass filters
- filter types (e.g., Butterworth, Chebyshev, etc.)
- low and/or high pass cut-off frequencies.

Since the power density spectra of the EMG contain most of their power in the frequency range of 5–500 Hz at the extremes, the journal will not accept reports in which surface EMG was filtered above 10 Hz as a low cut-off, and below 350 Hz as the high cut-off; e.g., 10–350 Hz is preferred for surface recording. Filtering in the band of 10–150 Hz or 50–350 Hz, for example, is not acceptable as portions of the signal's power above 150 Hz and below 50 Hz are eliminated. This should be kept in mind when designing a study's protocol. Exceptions will be made only in rare cases that carry full scientific justification. Intramuscular recording should be made with the appropriate increase of the high frequency cut-off to a minimum of 450 Hz. A bandpass filter of 10–450 Hz is therefore required. Needle recording should have a bandwidth of 10–1.500 Hz [9].

## 2.2 Available commercial solutions

Currently, there are no sales of voltage amplifiers directly recommended for EMG measurements. However, the market offers a whole range of dedicated sets for recording, processing and analysis of muscle activity in laboratory, clinical and field conditions. The basic parameters (made available by the manufacturer) of such devices are: sampling rate of 1-3 kHz, 16 bit resolution, CMRR > 100 dB, input impedance > 100 M $\Omega$ , number of simultaneous recording channels 4-32, and wireless data transfer from the electrodes to the recording equipment (up to 20 meters). However, there is no information about technical data of amplifiers used in these devices.

These types of kits are provided with both diagnostics and medical treatment for patients and athletes. The manufacturer assumes the operation of the device mainly by physicians and physiotherapists, so a number of facilities are provided to facilitate the operation of the electronic system for non-engineers. In modern sets, users can not make own modifications and changes. This systems (hardware and software), allows visualizing the muscle activity on the screen in real time. The patient can correct the muscle contraction activity on a regular basis by observing on screen what he is not able to feel. This method is called EMG biofeedback, in other words, a substitute feedback because it replaces what the body cannot do with motor dysfunction.

## 3. ANALYSIS OF POSSIBLE SOLUTIONS

The purpose of the study was to develop a system for conditioning the signal coming from the measurement of myoelectric signals from the forearm. It is important that the measurement was carried out in stationary working conditions (the subject was sitting). Therefore, in designing it, the size and mobility of the system was secondary. Ultimately, however, the EMG Signal Recording System is supposed to work during the athlete's physical activity [10].

The EMG signal conditioning system mostly consists of components responsible for signal strength and filtering. During testing, the power supply consisted of two 9V batteries connected in such a way as to give the amplifiers a symmetrical  $\pm 9V$  power supply. The influence of individual components on EMG signal quality is shown in the following chapters.

### 3.1 Gain

The main idea of the presented project was a construction which would have good technical parameters and would be cheap. It is important that there are no solutions based on precision measuring amplifiers. Their parameters often exceed the guidelines recommended by SENIAM. Therefore, it

seems economically unjustified to use them. Additionally, it is worth noting that on the basis of many publications [11,12] the most interesting EMG signal is the information contained in frequencies below 1000Hz. Therefore, its frequency response is not a challenge for most popular operational amplifiers.

This paper focuses on comparing two types of amplifiers. Representative of cheap, popular operational amplifiers and a measuring amplifier. Among the popular amplifiers, three types have been pre-tested: TL064, TL074, LM324. The results are shown in chapter 4. The catalogue parameters of the two tested amplifiers are shown in Table 1 [13,14]. It should be noted that the values of the frequency bands and the CMRR coefficient presented in the table are influenced by G parameter. Therefore, the presented data should be considered as indicative. In addition, it is worth mentioning that for the INA128 precision amplifier, the catalogue card is more elaborate, providing more information (e.g., CMRR for some selected G parameter values).

Table 1. Typical performance parameters of operational amplifiers.

Parameter	TL074	INA128
Supply Voltage	$\pm 18V$	$\pm 15V$
Power Consumption	1.4mA	700 $\mu A$
Input Impedance	$10^{12}\Omega$	$10^{10}\Omega$
Common Mode Rejection Ratio (Rs = 50 $\omega$ )	86dB	>100dB
Range Of Gain	Infinite	10000
Gain Bandwidth	3MHz	200 kHz for G=100

The first one (TL074) belongs to the popular cheap operational amplifiers (cost about 0.50EU<sup>1</sup>). The second (INA128) is a precision amplifier (about 7.5 EU<sup>2</sup>).

As mentioned before, in the case of recording of myoelectric signals, the difference of signals registered with two appropriately placed electrodes is amplified. That is why the preamplifier works in a differential circuit. As long as the INA128 is internally implemented in such an arrangement, we have to deal with 'raw' amplifiers (four operational amplifiers in an enclosure) for the common amplifiers in question to be connected in the appropriate configuration.

The TL064 amplifier connection system was tested in two variants, the standard operational amplifier and its development in the form of voltage duplicators on both inputs of the amplifier.

<sup>1</sup>[http://pl.rs-online.com/web/p/wzmacniacze-operacyjne/0302621P/?origin=PSF\\_430779|alt](http://pl.rs-online.com/web/p/wzmacniacze-operacyjne/0302621P/?origin=PSF_430779|alt) (2017.06.24)

<sup>2</sup><http://www.tme.eu/pl/details/ina128pa/wzmacniacze-operacyjne-tht/texas-instruments/> (2017.06.24)

Considering the catalogue data supplied by the manufacturers, it is important to note that only the INA128 complies with the criteria set for the SENIAM guidelines previously provided. However, as will be shown later in the article, the actual results that deviate from the catalogue data, especially when considering the system as a whole (with the filter part).

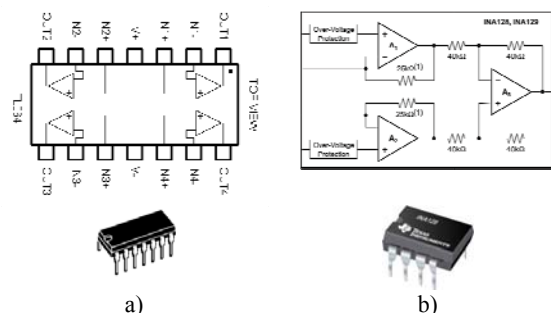

Fig. 1. Internal schematics of integrated circuits  
a) TL064, b) INA128.

### 3.2 Filtering

A number of EMG analysis studies confirm that the most useful information can be found in the frequency band between 10Hz and 1kHz [11,13].

As a result, when signal conditioning is optimum for analogue-to-digital converters, the signal is often filtered from usable frequencies over analogue signals. For this purpose, analogue filters of different types are used, starting with the cheapest solution (passive filter of the first order) and ending with active filters (higher order).

In the presented studies, it was decided to use only a high pass filter with 10Hz cutoff frequency. The results will concern both the use of passive and active filter systems. The lack of a dedicated low-pass filter is dictated in two respects:

- scientific reports on analysis of EMG signals in higher frequencies,
- often the low pass filter works as an anti-aliasing filter. However, used A/D converters have such filters implemented.

Two types of high-pass filters were used in the study. The layout of the links is shown in the following section. The main advantage of active filtration is the higher roll-off of the frequency characteristic below the cutoff frequency (passive filtration 20dB/octave, 2nd order active filter 40dB/octave). As will be discussed later, the effect of phase shift in both cases is significant. In order to shorten the annotation later in the publication, the following symbols were adopted:

HP1 - first order passive filter,  
HP2 - second order active filter (Sallen-Key).

Measurements were made for combination systems:  
amp + HP - order of the system: amplifier-filter,  
HP + amp - order of the system: filter-amplifier,  
The results of measurements on real systems are presented below.

### 4. TESTS

The design of the system was focused on determining the effect of the end effect on the combination of the amplifier-filter system by testing its possible variants. The block diagram of the test system is shown in Figure 2.

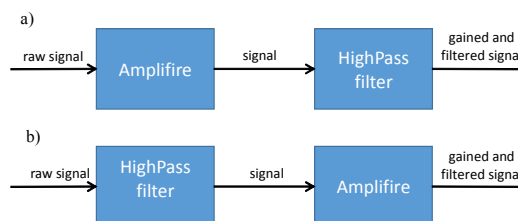

Fig. 2. Flowchart of the tested system

The parameters tested were: gain mode, common mode rejection ratio (CMRR), phase shift, total harmonic distortion (THD).

#### Gain mode

As mentioned above, bioelectric signals have very low signal levels (of the order of several mV). Therefore, they need to be strengthened. According to the SENIAM guidelines they should reach the order of several hundred. In our case it was decided to gain  $G = 500$ . This was theoretical because the real gain after resistor selection was higher (about 507). This is important information that influences the CMRR value.

#### Common Mode Reject Ratio (CMRR)

This parameter determines to what extent the differential amplifier is able to suppress the same signal components on both inputs of the amplifier. This parameter is defined by the formula:

$$\text{CMRR} = 20 \log_{10} \left( \frac{A_d}{|A_{cm}|} \right) \quad (1)$$

where:

$A_{cm}$  is a concurrent signal amplification,

$A_d$  is a differential signal amplifier.

It should be noted that 10 mV (p-p) was used as the differential signal level, while 1 V (p-p) was used for the concurrent signal. The value of 1V was chosen arbitrarily, but was guided to significantly exceed the level at which the amplifier was measured during EMG measurements. So in more difficult working conditions. For differential signal (10mV), the intention was to determine the operating parameters of the amplifier for voltages close to real EMG signals.

### Phase shift

The knowledge of this parameter indicates to what extent the system interferes with the phase of the individual components of the signal. It should be noted, however, that most of the current EMG signal analysis is primarily based on a non-phase-shift energy approach.

### Total Harmonic Distortion (THD)

Total harmonic distortion is a parameter determining the share of harmonic distortion in a signal. It is better if THD value is lower. In this test to determine the THD level, the first five harmonic components were used.

### 4.1 Connections diagrams

Figure 3 shows the connection diagrams used to determine the characteristics of the tested amplifiers. Figure 4 shows the connections for used filters.

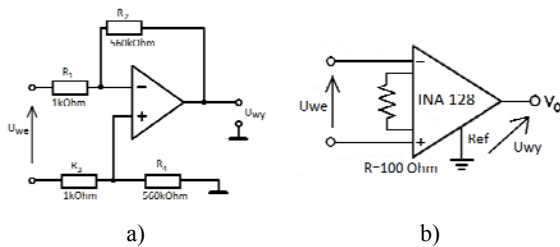

Fig. 3. Amplifier connection diagram a) popular operational amplifier, b) precision amplifier.

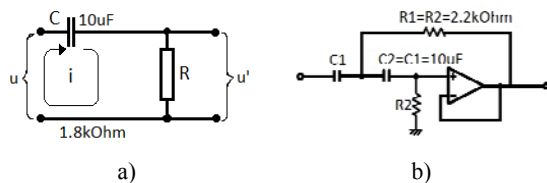

Fig. 4. Schematic of filter a) passive, b) active (Sallen-Key)  $Q = 0.5$ .

The known electric relationships are used to calculate the resistance and capacitance values. It should be noted, that the actual values of the cutoff band differ from the calculated values. Table 2 summarizes the computed and measured filter and gain parameters (for 100Hz). As the tests show, joining the filter system influenced the gain (decreasing it).

Tabela 2. Real and computed parameters

Parameter	Real	Compute
Gain for TL064	508	560
Gain for TL074	515	560
Gain for LM324	534	560
Gain for INA128	521	501
High Pass Filter 1 <sup>st</sup> order	7.6Hz	8.8Hz
High Pass Filter 2 <sup>nd</sup> order (Sallen-Key'a) $Q=0.5$	10.9Hz	7.2Hz

### 4.2 Preliminary selection of low-cost operational amplifier

In the first step we investigated the selected popular operational amplifiers (TL064, TL074, LM324). Figure 5 shows the results of the measurement of basic parameters. All amplifiers were tested in the circuit as differential amplifier (Figure 4) and under identical conditions (the same resistances).

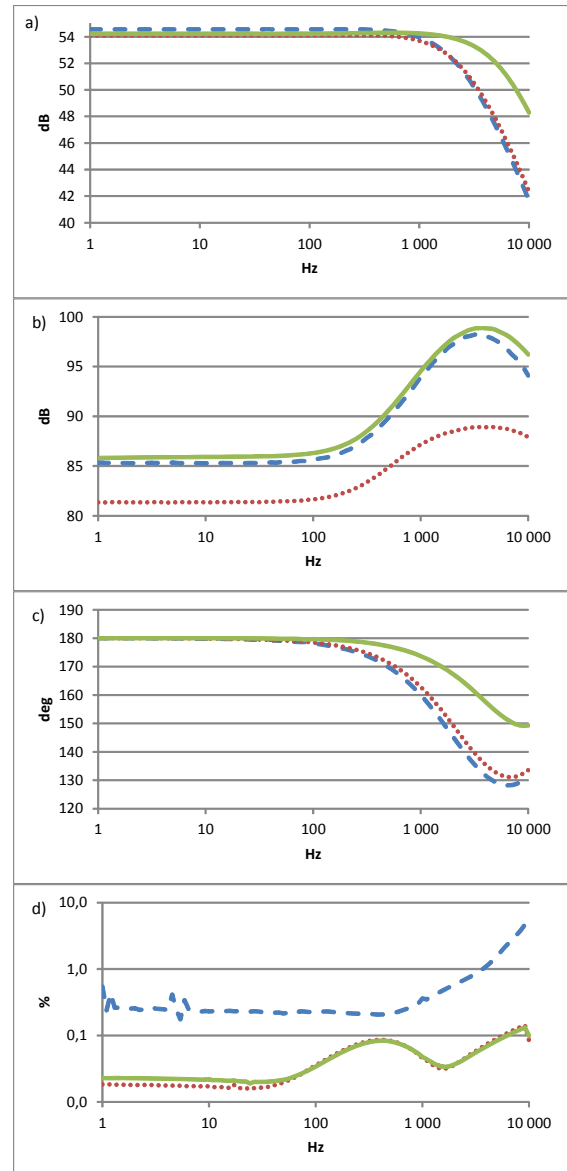

Fig. 5. Characteristics of amplifiers: LM324 (broken), TL064 (dot), TL074 (solid); a) gain, b) CMRR, c) phase shift, d) THD.

Based on the measurements, TL074 was used for further tests. Among the tested amplifiers, it has the widest band gain linearity, highest CMRR, stable phase shift and lowest THD values.

#### 4.3 TL074 vs INA128

This section presents a comparison of the determined parameters of tested amplifiers without filter systems. In Figure 5. a) the linearity of the gain is given, referring it to gain at frequency 100Hz. Both amplifiers had chosen resistance with the gain that was about 54dB. In tests of the phase shift, the offset is referred to the value obtained for 100Hz, too.

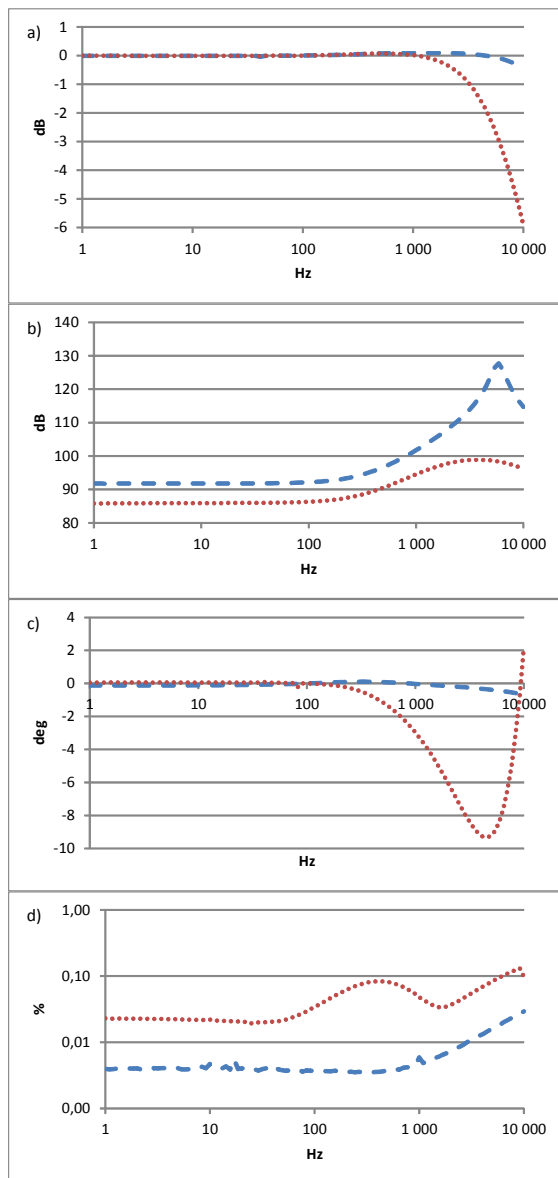

Fig. 6. Characteristics of amplifiers: INA128 (broken), TL074 (dot):

a) gain linearity, b) CMRR, c) phase shift, d) THD.

For TL064 amplifier, the gain change more than -3dB is above 6kHz, which is outside of useful band for analysing EMG signals. The minimum obtained value for CMRR parameter was 85dB for TL064, while for INA128 it was close to 92dB. In all cases, the INA128 amplifier features better performance. However, for the frequencies below 1000Hz the TL074 amplifier parameters are also satisfactory and the input signal distortion is small.

#### 4.4 Gain

Figure 7 shows the impact of applied filters on the signal gain. The results obtained for the measurements made using first passive high pass filter (HP1) and second order active filter (HP2).

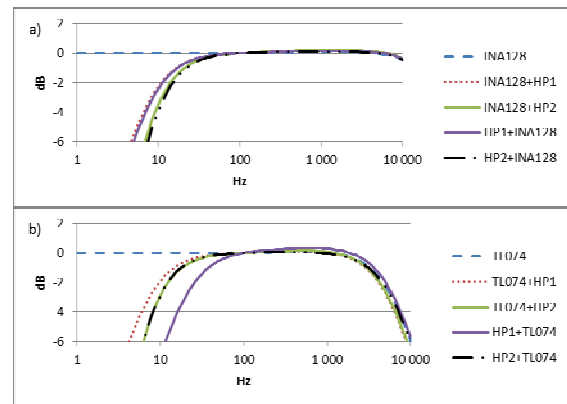

Fig. 7. The impact of applied filters on the signal gain. a) INA128, b) TL074

The results shown in Fig. 7. coincide with theoretical assumptions. However, it is interesting to influence the type and location of the filter. In the case of an HP2 filter system, both systems behave predictably - according to the theory. Only HP1 filter change the cutoff frequency in set with TL074 amplifier, depending on where filter is located. For the HP1 filter located in front of the amplifier (HP1 + TL074) the cut-off (-3dB) occurs at 18.6Hz. For the HP1 filter system after the the amplifier, the cut-off frequency is 7Hz. It should also be noted that the use of filtration has affected the gain in the conduction band. However, this impact was small, not exceeding -1dB.

#### 4.5 Common Mode Rejection Ratio (CMRR)

The impact of the applied filters on the common mode rejection ratio (CMRR) is shown at Fig 8.

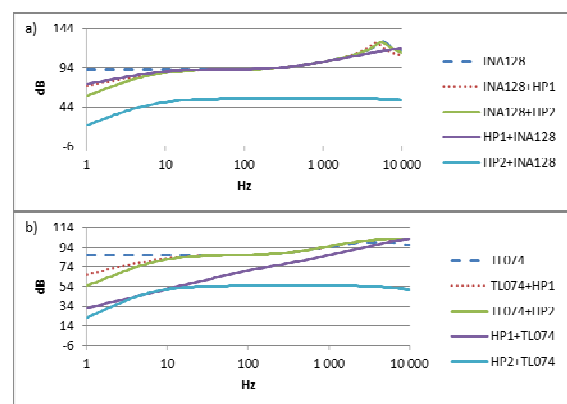

Fig. 8. The impact of the applied filters on the CMRR. a) INA128, b) TL074

The results obtained for the measurements made using first passive high pass filter (HP1) and second order active filter (HP2). Based on the results

shown in Fig. 8 it can be stated that the strong influence of the filtration site is noticeable. For both test amplifiers, the CMRR is noticeable when the filter is in front of the amplifier. On the other hand, placing the filter behind the amplifier does not negatively affect the CMRR. Therefore, it is strongly recommended to use such a layout. It should also be noted that in the filter band (below 10Hz) the CMRR decreases significantly.

#### 4.6 Phase shift

The influence of the applied filters on the phase shift of the system is presented at Fig. 9. The results obtained for the measurements made using first passive high pass filter (HP1) and second order active filter (HP2).

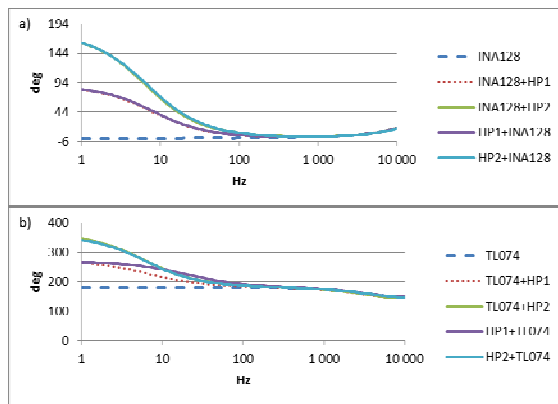

Fig. 9. The influence of applied filters on the phase shift. a) INA128, b) TL074

In the case of phase shift, the trend of changes are similar when using the INA128 and TL074. Clearly, there is a stronger phase shift for active filtering (HP2), which is in line with the theoretical principles.

#### 4.7 Total Harmonic Distortion (THD)

The determined harmonic distortion coefficient for all the examined cases was at the level of the measurement system distortion and in the 10-1000Hz band did not exceed 1%. The impact of the filter type (HP1 / HP2) or its location relative to the amplifier (before/behind) was not observed.

#### 4.8 Voltage Rectifier

For EMG measurements, the least amount of signal source load is very important. This is achieved by increasing the input impedance of the measuring system. It is a well-known practice to use the voltage rectifier. It allows increasing the input impedance by repeatedly limiting the load (current consumption) of the measured system. The scheme of applied the solutions is shown in Fig. 10.

Measurements were made to verify the effect of the repeater system on the basic parameters of the amplifier.

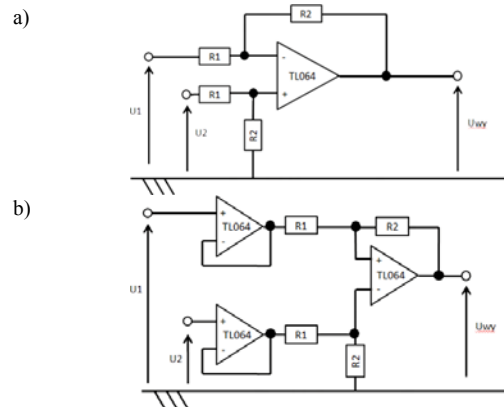

Fig. 10. Scheme of connections TL064 with a) differential amplifier, b) differential amplifier with voltage rectifier.

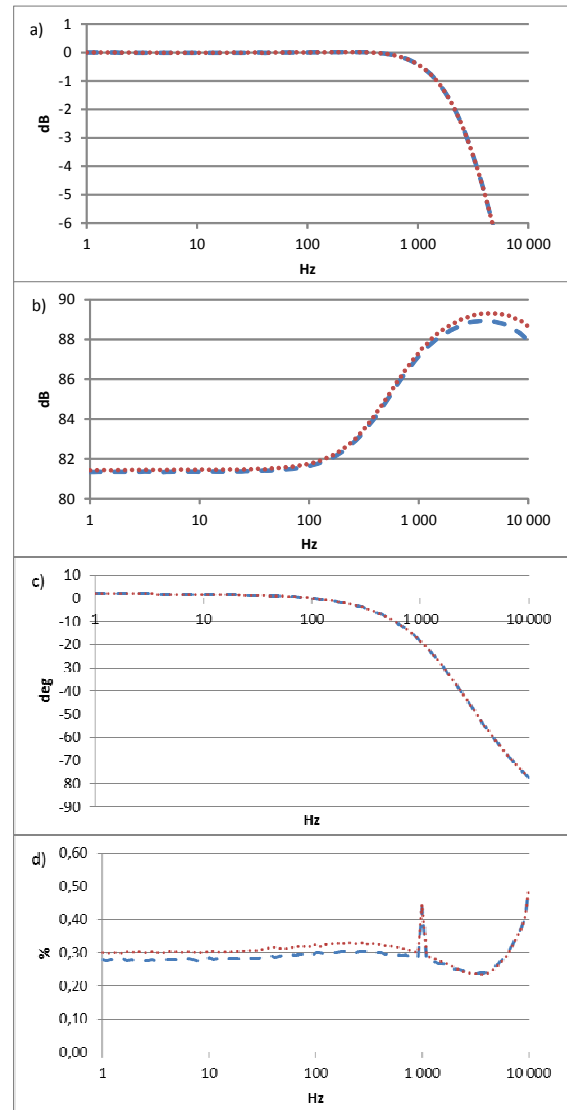

Fig. 11. Characteristics: non-voltage rectifier system (broken), voltage rectifier (dot); a) gain linearity, b) CMRR, c) phase, d) THD



In the case of the systems under consideration, the input impedance is  $10^{12}\Omega$ . This value is high enough, so it is not needed to use a voltage rectifier. Note that the input impedance of the measuring system recommended by SENIAM is a minimum of  $10^9\Omega$ . So in this case the condition is fulfilled.

## 5. CONCLUSION

The article presents an analysis of the measurement difference between a low cost amplifier. Studies have been conducted to verify the suitability of the cheap solution for EMG signal acquisition. The system proposed by the author has been designed and validated in accordance with ISEK and SENIAM requirements. The test signal conditioning system is stationary. The open form of the implemented system gives the possibility to adapt the system to different measurement needs (high mobility, low weight, long work without power supply etc.).

Considering only the catalogue data supplied by the manufacturers, it can be noted that only the INA128 complies with SENIAM requirements. The paper shows that received results are coherent with the catalogue data, also the amplifier with the filter part. In all cases, the INA128 precision amplifier has better parameters, especially in all the tested bands. However, the TL074 amplifier parameters are also satisfactory for EMG signal recording purpose.

## ACKNOWLEDGEMENT

The study described in this paper has been performed within the project No. 11.11.130.955.

## REFERENCES

- Smoleń M. Electromyography and its application, In: Tadeusiewicz R, Augustyniak P. eds. Basic biomedical engineering, AGH University of Science and Technology Press, Vol 1, 2009. 163–174 (in Polish).
- Brabska-Chrzastowska J. Other electrographies, In: Tadeusiewicz R, Augustyniak P. eds. Biomedical engineering: a book of modern magic knowledge – a nice and approachable version, AGH University of Science and Technology Press, 2008, 145–149 (in Polish).
- Grzeczka A, Kohut P, Kłaczyński M, Wittbrodt E, Uhl T. Motion analysis of a kitesurfer employing a vision-based measurement system. *Journal of Vibroengineering*, 2016, 18(3), 1884-1892.
- Pracki T, Pracka D. Bioelectric amplifier. *Sen*, 2002, 2(1), 15–19 (in Polish).
- Nagel JH. Biopotential amplifier. *The Biomedical engineering handbook: Second Edition*, Boca Raton, CRC Press LLC, 2000.
- Cheney PD, Kenton JD, Thompson RW, McKiernan BJ, Lininger RE, Trank JW. A low-cost multi-channel EMG signal processing amplifier. *Journal of Neuroscience Methods*, 1998, 79(1), 123-127.
- Moura ILB, Ozelim LCSM, Soares FA. Low Cost Surface Electromyographic Signal Amplifier Based On Arduino Microcontroller, *Engineering and Technology International Journal of Electrical and Information Engineering*, 2014, 8(2), 303-307
- <http://www.seniam.org/>
- Merletti R. The Standards for Reporting EMG Data, *Journal of Electromyography and Kinesiology*, 1999, 9(1), III-IV.
- Grzeczka A, Barański R. Problems in estimation of hand grip force based on EMG signal, *Diagnostyka*, 2015; 16(2): 21-26
- Konrad P. ABC EMG: A Practical Introduction to Kinesiological Electromyography, Technomex, Gliwice, 2007 (in Polish)
- Stegeman DF, Hermens HJ. Standards for surface electromyography: the European project (SENIAM), In: Hermens HJ, Rau G, Disselhorst-Klug C, Freriks B. (Eds.), *Surface Electromyography Application Areas and Parameters. Proceedings of the Third General SENIAM Workshop on surface electromyography*, Aachen, Germany, 1998, 108–112.
- TL074. Low-noise JFET quad operational amplifier; Datasheet - product data, Texas Instruments, <http://www.ti.com>
- INA128, INA129, Precision, Low Power Instrumentation Amplifiers – product data, Texas Instruments, <http://www.ti.com>

Received 2017-06-08

Accepted 2017-11-03

Available online 2017-11-06



**Robert BARAŃSKI** Ph.D. is a postdoctoral researcher in the Department of Mechanics and Vibroacoustics, AGH-UST. His scientific interests focus on biomechanics, EMG signals analysis, building flexible diagnostic and measurement systems.



**Anna GRZECZKA** M.Sc. is a Ph.D. student in the Faculty of Mechanical Engineering. Her scientific interests focus on biomechanics, analysis of human movement and medical diagnostic.

