

# Single and Three -Phase PWM AC/AC Converters as Semiconductor Transformers

Ryszard Strzelecki  
Gdansk University of Technology  
Gdansk, Poland  
ORCID ID: 0000-0001-9437-9450

Natalia Strzelecka  
Gdynia Maritime University  
Gdynia, Poland  
ORCID ID: 0000-0002-5976-6903

**Abstract**—AC voltage transformation circuits contain pure or reactance PWM AC/AC converters. These circuits can be treated as AC/AC semiconductor transformers. This paper reviews single-phase and three-phase topologies: both non-isolated and isolated, single as well as two quadrant structure. Additionally, this paper present selected examples of their applications.

**Keywords**— AC/AC converters, PWM AC energy conversion, line conditioners

## I. INTRODUCTION

The industry commonly uses AC line conditioners with thyristor power controllers to perform the function of an AC voltage transformation circuit. Main issues related to their applications include higher harmonics in the source current, displacement power at phase angle control and subharmonics at integral control. In order to eliminate these unfavourable properties a PWM AC/AC converters are suggested [1–3]. This happened because additional electromagnetic transformer is required when the load voltage increases above the supplying voltage.

[4-8] show the basic energetic properties of reactance PWM AC converters with the capability to increase the AC load voltage above the AC line supplying voltage without an electromagnetic transformer. The PWM AC converters contain an extra passive element. This makes the topologies of these converters similar to popular DC/DC converter topologies. Both PWM AC/AC converters perform the tasks of AC/AC semiconductor transformer. The lack of synchronization with the power supply network is an important advantage of PWM AC/AC, when compared to AC/DC/AC converters, is the. Works [9-13] describe opportunities to apply AC voltage transformation converters to direct buck-boost.

This paper provides a comprehensive overview of 1- and 3-phase topologies of reactance PWM AC/AC converters, allowing a first approximation of their application potential.

## II. SINGLE-PHASE TOPOLOGIES

### A. Non-isolated Circuits

Fig. 1 shows basic symmetrical 1-phase reactance AC/AC PWM converter topologies. All topologies, except the Buck AC/AC PWM converter, include additional reactance elements. the reactance elements include in those topologies (boost, buck-boost, Ćuk, Zeta and Sepic), make it possible to increase the output voltage above the supply voltage with (buck-boost and Ćuk) or without (boost, Zeta and Sepic) phase inversion. Fig. 2 shows symmetrical topologies of two quadrant 1-phase PWM AC/AC converters. They are obtained by connecting single quadrant topologies from Fig. 1.

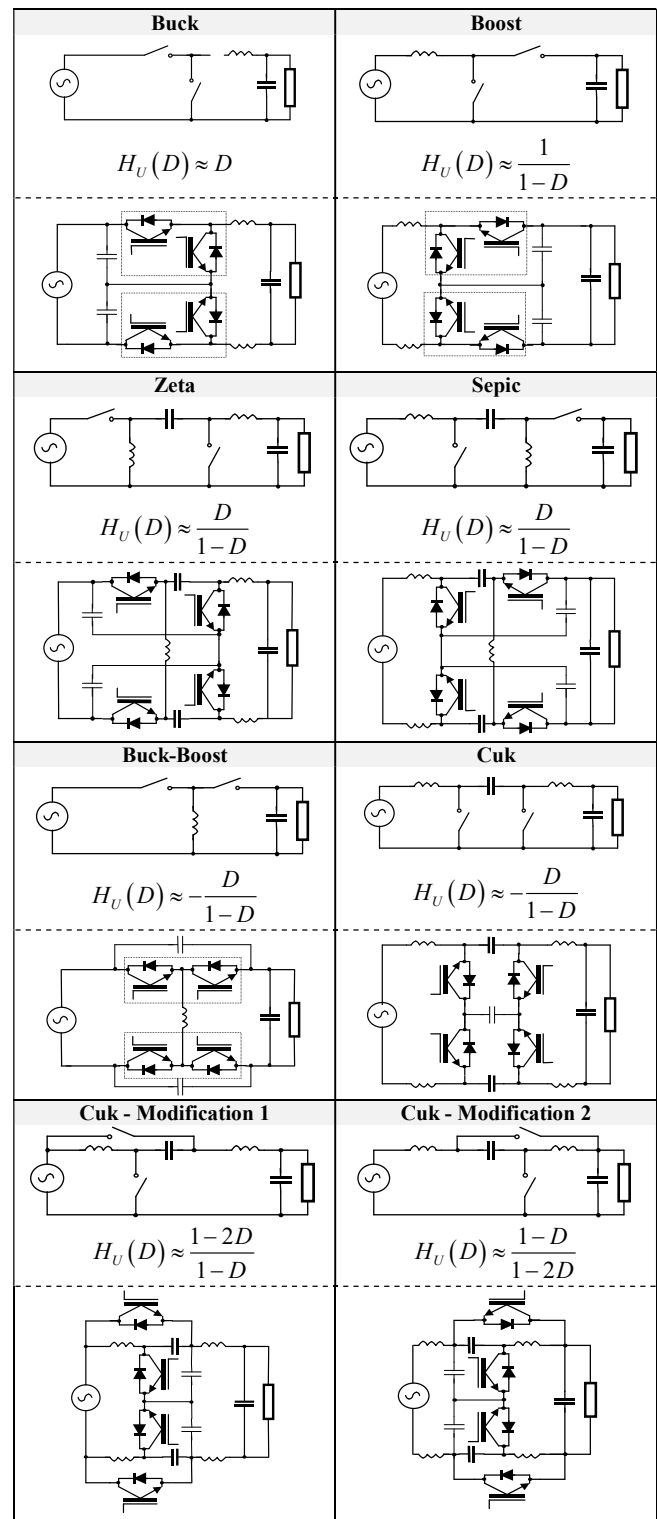

Fig.1. The topologies of 1-phase AC/AC semiconductor transformers - basic and symmetrical circuits ( $H_v(D)$  – voltage transfer function)

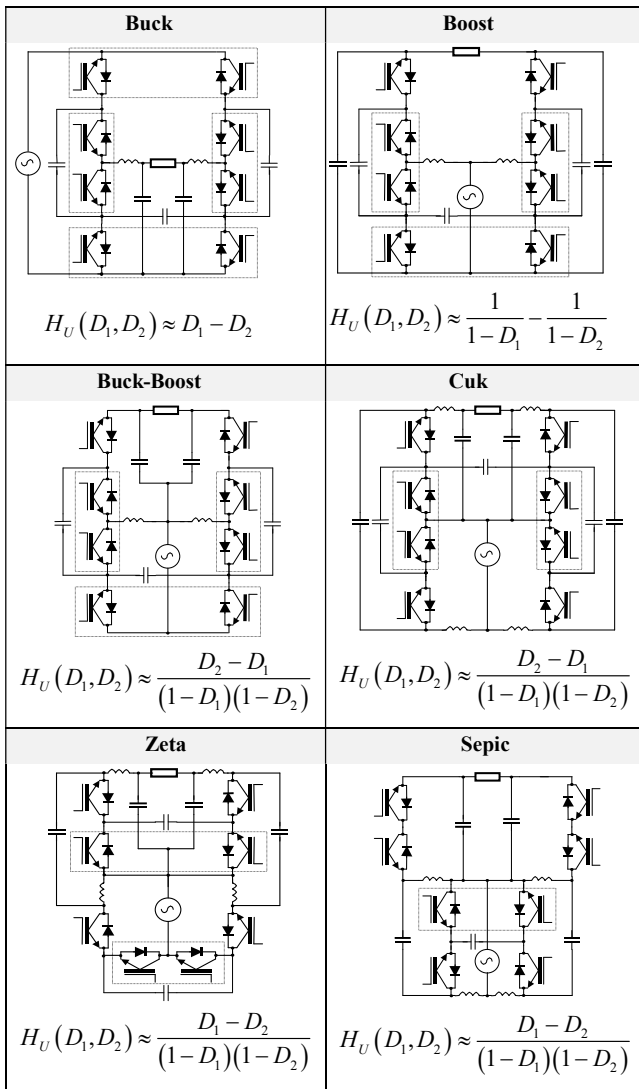

Fig.2. Two quadrant of 1-phase AC/AC semiconductor transformers ( $H_U(D_1, D_2)$  - dual-argument voltage transfer function, whereby  $H_U(D_1, D_2) = -H_U(D)$  for  $D = D_1 = 1 - D_2$ )

### B. Isolated Circuits

Fig. 3 shows example of simplified structures of 1-phase isolated PWM AC/AC converters topologies, where additional voltage transformation is realized by means of HF isolating transformer. In order to illustrate the operation of such converters, Fig. 4 illustrates typical output voltage waveforms of an Sepic type AC/AC converter for different transformer ratio and duty cycle  $D$ .

## III. THREE-PHASE TOPOLOGIES

### A. Non-isolated Circuits

Fig. 5 shows example of basic symmetrical 3-phase PWM AC/AC semiconductor transformer topologies. Among of these topologies, as in the case of 1-phase systems, only the Buck AC/AC PWM converter does not contain additional reactance elements. Remaining topologies (boost, buck-boost, Ćuk, Zeta and Sepic) belong to reactance family and enable increasing output voltage above supplying input voltage with (buck-boost and Ćuk) or without (boost, Zeta and Sepic) phase inverting.

In 3-phase circuits, asymmetrical topologies of PWM AC/AC converters can be formatted as in Fig. 6. because

they show similar energetic properties of PWM AC/AC converters as symmetrical topologies. Fig.7 highlights this similarity by illustrating time waveforms of phase output voltages.

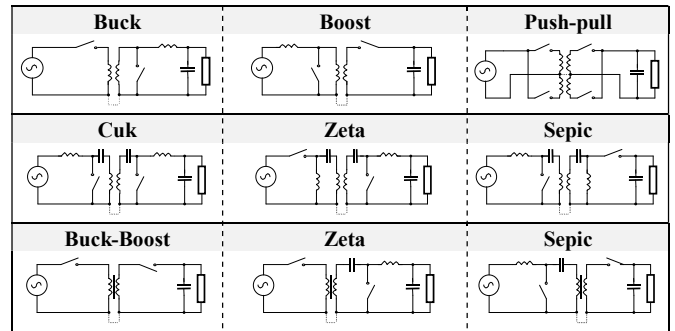

Fig.3. Example of simplified topologies of 1-phase isolated AC/AC semiconductor transformers

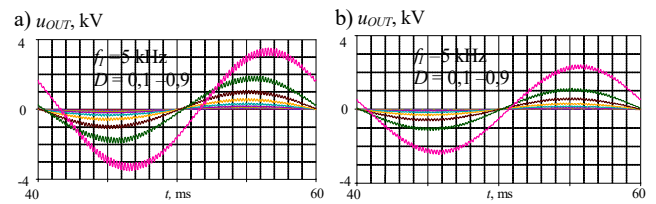

Fig.4. Output voltage waveform of 1-phase isolated AC/AC Ćuk type converter, a) for transformation ratio 1:1, b) for transformation ratio 2:1

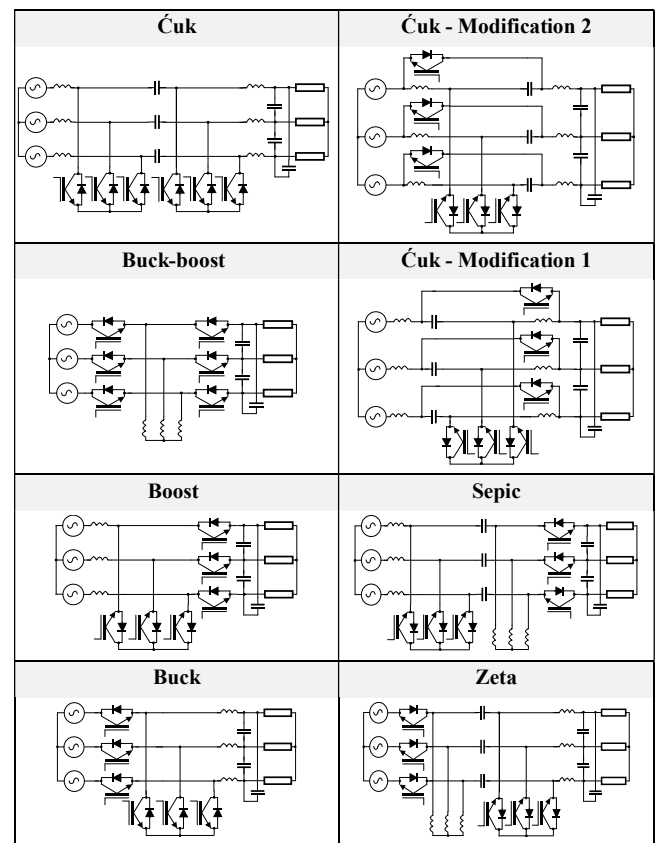

Fig.5. Example of basic symmetrical 3-phase PWM AC/AC semiconductor transformer topologies

Two-quadrant topologies of 3-phase PWM AC/AC converters can be formatted based on symmetrical and asymmetrical structures (as in the case of single-phase systems) (Fig. 8). Other two-quadrant structures can be built in a similar to that in a single-phase circuit.

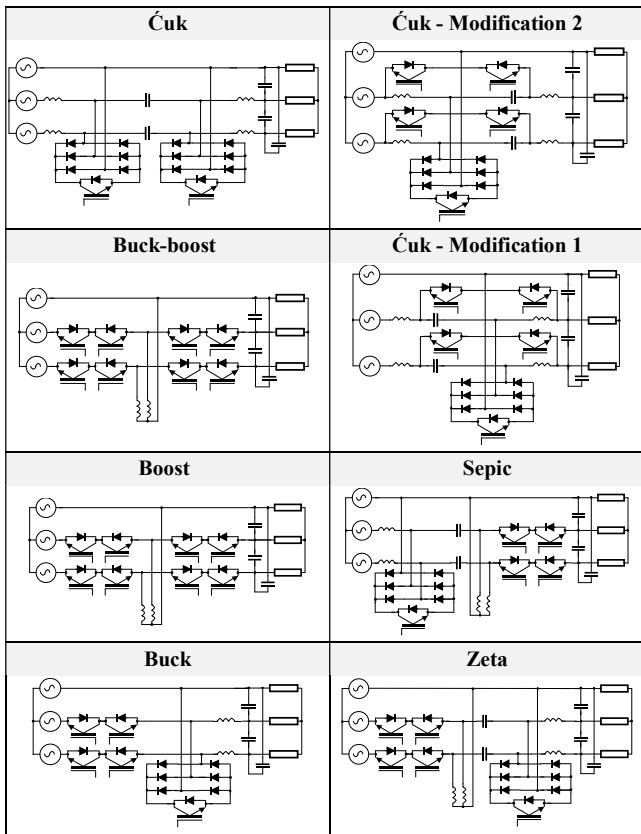

Fig. 6. Basic asymmetrical 3-phase AC/AC semiconductor transformer topologies

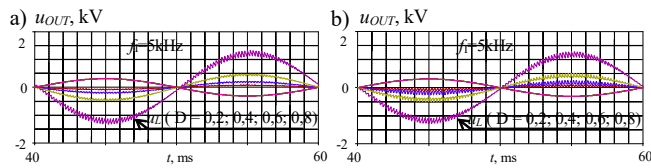

Fig. 7. Output voltage waveform of 3-phase buck-boost AC/AC converter topology: a) symmetrical (Fig. 5), b) asymmetrical (Fig. 6)

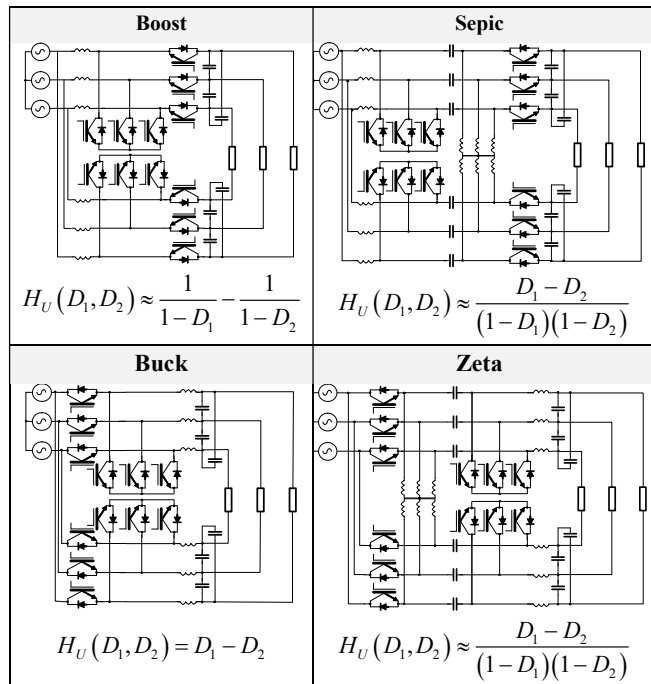

Fig. 8. Examples of the two quadrant topologies of 3-phase AC/AC semiconductor transformers

### B. Isolated Circuits

Examples of basic symmetrical structures of 3-phase isolated AC/AC semiconductor transformers are shown in Fig. 9. In these semiconductor transformers, additional voltage transformation is realized through the insulation of HF transformer.

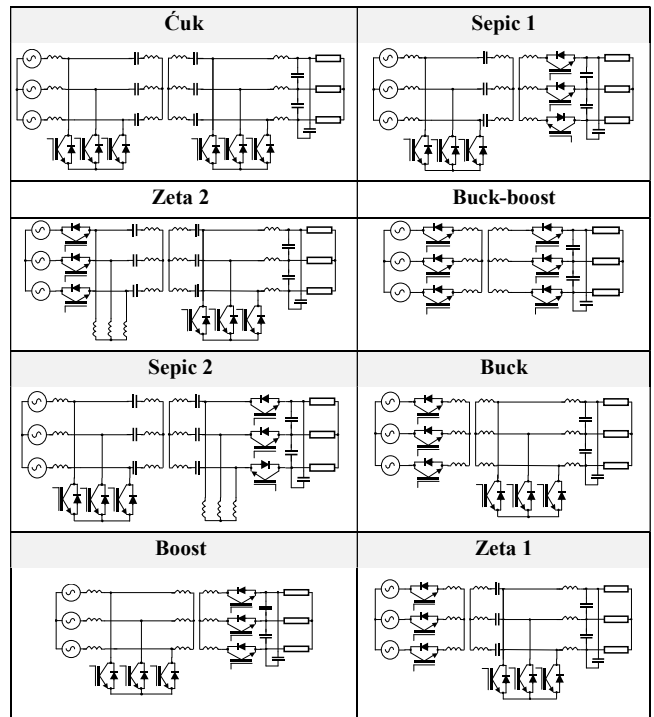

Fig. 9. Examples of simplified structures of isolated 3-phase AC/AC semiconductor transformers

### IV. EXEMPLARY OF APPLICATIONS

The section presents exemplary 1-phase applications of the PWM AC/AC converters. As 3-phase applications are similar, their presentation is not crucial for the overall understanding of the topologies.

Fig. 10 shows the use of a direct AC/AC semiconductor transformer. Other topologies (Ćuk, Zeta or Sepic) from Fig. 1 can be used in similar applications.

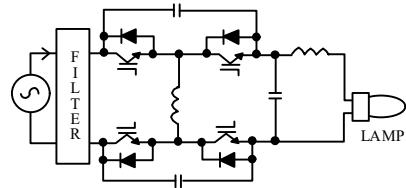

Fig. 10. Sodium lamp supplier with buck-boost AC/AC semiconductor transformer

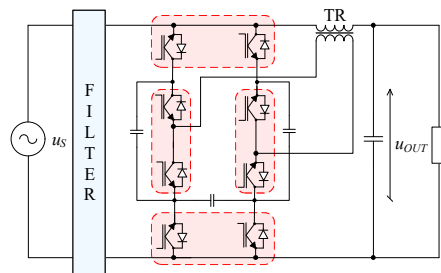

Fig. 11. Voltage regulator/stabilizator with two quadrant buck AC/AC semiconductor transformer

There is successive example in Fig. 11, which depicts serial voltage regulator with two quadrant buck PWM AC/AC converter shown in Fig. 2. Detailed description of this regulator with two auxiliary resonance switches is presented in [11], whereas in Fig. 12 there are exemplary time waveforms, which illustrate one operation.

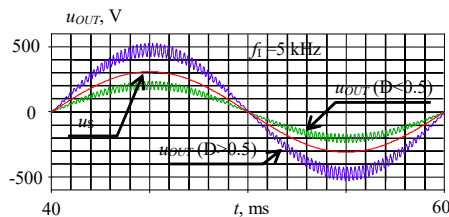

Fig.12. Output voltage waveform of serial voltage regulator shown in Fig.11

Fig. 13 shows the final example of the PWM AC/AC converter to compensate of voltage sags in electric power distribution systems [12].

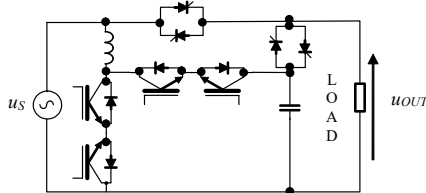

Fig.13. Single-phase sag compensator with boost transformer

## V. CONCLUSIONS

The paper reviewed and outlined exemplary applications one-phase and three-phase AC/AC converter topologies. The main advantage of these systems in comparison with AC/DC/AC converters, i.e. converters with DC link circuit, lies in that there is no need for synchronization with the network. In addition to their control functions, The PWM AC/AC systems under consideration with DC transformers, can also be found in the so-called "intelligent transformers" connecting systems of the same frequency. In such case, however, the systems in which HF transformers are not submagnetized by the mains frequency current should be prioritized solutions.

The examples presented in the paper show interesting opportunities for applications of the PWM AC/AC converters as semiconductor transformers.

## ACKNOWLEDGMENT

The research is conducted as a part of the project: *Hybrid distribution transformer (HDT) as an active element of modern "Smart Grid" systems*, application number: POIR.04.01.02-00-0083/17, funded by the National Centre for Research and Development NCBIR - Poland.

## REFERENCES

- [1] Ziogas P. D., Vincenti D., Joos G.: *Practical PWM AC controller topology*. IAS Conf. Rec., vol. 1, pp. 880-887, 1992.
- [2] Vincenti D., Jin H., Ziogas P.: *Design and implementation of a 25kVA three-phase PWM AC line conditioner*. IEEE 0-7803-1227-9/93, 1993
- [3] Strzelecki R., Fedyczak Z.: *Properties and structures of three-phase PWM AC power controllers*. PESC'96, pp. 740-746. Baveno, Italy, 1996.
- [4] Fedyczak Z., Strzelecki R.: *Three-phase PWM AC line boost and buck-boost conditioners under small quality factor circumstance*. EPNC'98, pp. 184-187. Liege, Belgium, 1998.
- [5] Kim J. H., Min B. D., Kwon B. H., Won S. C.: *A PWM Buck-Boost AC chopper solving the commutation problem*. IEEE Trans. on Ind. Electr., Vol. 45, No. 5, Oct. 1998.
- [6] Fedyczak Z., Strzelecki R., Skórski K.: *Three-phase PWM AC line conditioner based on the Ćuk converter topology: study of the basic energetic properties*. EPE'99, CD (P.1- P.10), Lausanne, Switzerland, 1999.
- [7] Zinowiew G. S., Obuchow A. Y., Otczenasz W. A., Popow W. I.: *Transformerless step-up and step-down PWM AC line conditioners*. (In Russian). Technicznaja Elektrodinamika, Vol. 2, pp. 36-39. Nacjonalna Akademia Nauk Ukrainy. Kijew 2000.
- [8] Fraćkowiak L., Fedyczak Z., Strzelecki R.: *Basic properties of energy transfer in matrix-reactance PWM AC line conditioners based on Zeta or Sepic converter topologies*. Proc. of XVI Symp. EPNC'00, pp. 131 - 134. Poznań-Kraków, Poland, 18 - 20 Sept. 2000
- [9] Fedyczak Z., Strzelecki R., Kasperek R., Skórski K.: *Three-phase self-commutated VAr compensator based on Ćuk converter topology*. PESC'00, vol. 1, pp. 494 -499. Galway, Ireland, 2000.
- [10] Ikriannikov A. Ćuk S.: *Direct AC/DC conversion without input rectification*. PESC'99, Vol. 1, pp. 181 - 186. Saint Luis, USA, 1999.
- [11] Oliveira J. C., Farias V. J., Freitas L. C., Vieira J. B.: *A serial regulator using soft switching PWM AC/AC full bridge-converter*. PESC'99, Vol. 1, pp. 193 - 198. Saint Luis, USA, 1999.
- [12] Montero-Hernandez O. C., Enjeti P. N.: *Application of a boost AC-AC converter to compensate for voltage sags in electric power distribution systems*. IEEE 31<sup>ST</sup> PESC'00, Vol. 1, pp. 470 - 475. Galway, Ireland. 18 - 23 June 2000.
- [13] Kaniewski J., Fedyczak Z., Benysek G.: *AC Voltage Sag/Swell Compensator Based on Three-Phase Hybrid Transformer With Buck-Boost Matrix-Reactance Chopper*, IEEE Transactions on Industrial Electronics, vol. 61, no. 8, pp. 3835-3846, Aug. 2014.

