

RYSZARD KATULSKI<sup>1</sup>, WOJCIECH SIWICKI<sup>1</sup>, JACEK STEFAŃSKI<sup>1</sup>, R. STUDAŃSKI<sup>2</sup>

<sup>1</sup>) Gdańsk University of Technology

Faculty of Electronics, Telecommunication and Informatics

Department of Radiocommunication System and Networks

11/12 Gabriela Narutowicza Street, 80-233 Gdańsk,

POLAND

<sup>2</sup>) Polish Naval Academy

Śmidowicza 69 Street, 81-103 Gdynia

[rjkat@eti.pg.gda.pl](mailto:rjkat@eti.pg.gda.pl), [wojciech.siwicki@eti.pg.gda.pl](mailto:wojciech.siwicki@eti.pg.gda.pl), [jstef@eti.pg.gda.pl](mailto:jstef@eti.pg.gda.pl),

## Software implementation of the RAKE receiver

### Abstract

*This paper presents concept of the RAKE receiver method with implemented algorithm of shifted phase WMSA filter (Weighed Multi-Slot Averaging). First, the RAKE receiver block diagram and WMSA filter analysis have been described. Next, the results of the simulation have been described. In summary usefulness of the concept has been confirmed.*

**Keywords:** navigation, RAKE receiver, WMSA filter

### Introduction

In real propagation environments, the transmitted signal is attenuated, reflected, dispersed and deflected by many obstacles between the transmitter and receiver. Those effects create a multipath signal which is received with different time delays and fading. Using DS-CDMA (Direct Sequence CDMA) technique gives an opportunity to receive those multipath signals. We can pick up those signals independently, if time difference between paths is greater than a duration of chip. This feature allows us to improve quality of received signal.

This paper presents basics of a RAKE receiver. Its functioning and possible difficulties in receiving multipath signals. Next the solution is presented (WMSA filters). At

the end of this paper results of implemented algorithm are presented.

Presented RAKE receiver with implemented algorithm of WMSA filter is being consider as a part of a navigation receiver in a ground systems.

### RAKE receiver technique

RAKE receiver uses time shifted receivers for independent picking up signal separated in time. It is set of correlation receivers working simultaneously. Block diagram of the discussed receiver is shown on Fig 1.

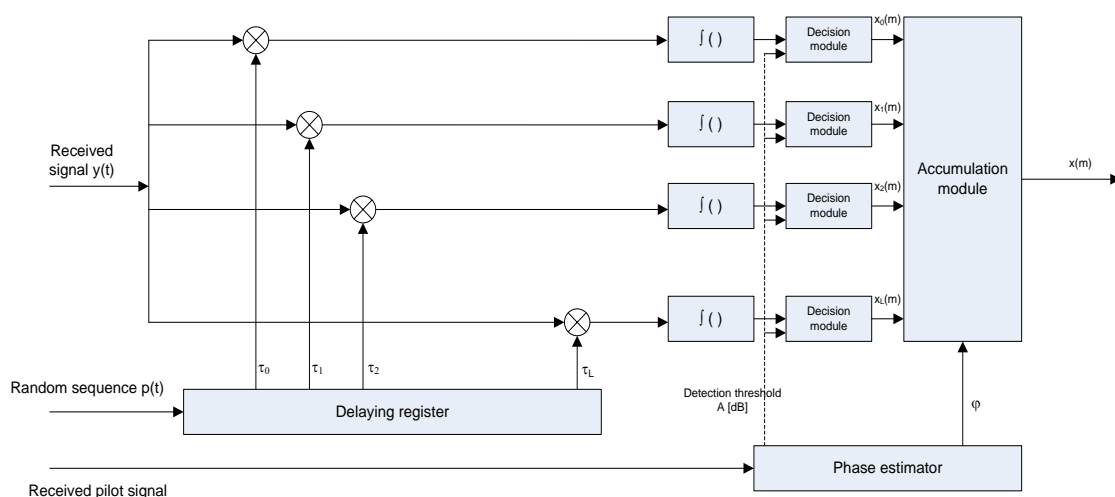

Fig.1. Block diagram of RAKE receiver

Receiver presented on Fig. 1 works as follow. Signal  $y(t)$  passes on group of correlators to which a random sequence (RS) is given. RS is delayed in every “branch” by time duration of a chip. Results are multiply by calculated weighted factor which represents impulse response of a channel. Subsequently all results pass on accumulation module.

It is a well-known fact that signal fading in multipath propagation is dependent on terminal velocity. The faster a terminal is moving the harder is to estimate phase shift [1], [2]. Therefore it is necessary to choose a suitable method that will prove itself as well in slow and fast signal fading. Filters working as a linear or Gaussian estimators are very popular technique. Wiener filters are also used, but they need statistical data regarding signal fading (which is impractical and in reality unrealizable). In this paper WMSA filter is presented. It is based on weighted factor sets using linear interpolation from every basic frame of data.



## WMSA filter

WMSA filter (Weighted Multi-Slot Averaging) is based on weighted factor sets using linear interpolation. WMSA filters with changeable factors allow better fading follow then filters with only linear interpolation or filters averaging pilot signal from two adjacent frames.

This paper was accepted the following assumption concerning frame structure. The frame contains of  $N_P$  bits of pilot sequence and then  $N_D$  bits of data sequence. Fig. 2 gives a time frame structure of transmitted data.

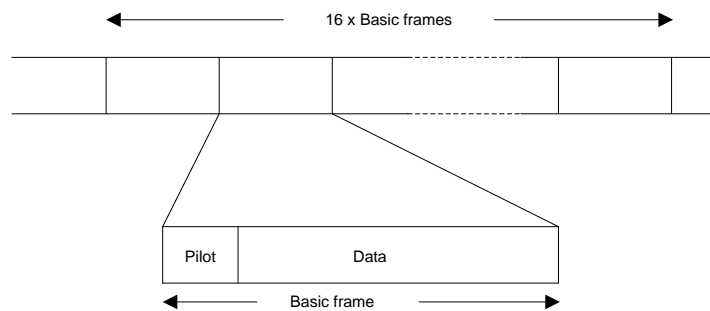

Fig.2. Frame structure

In order to receive data structures as in the above figure, you should use a Rake receiver, whose block diagram shown in Fig 3.

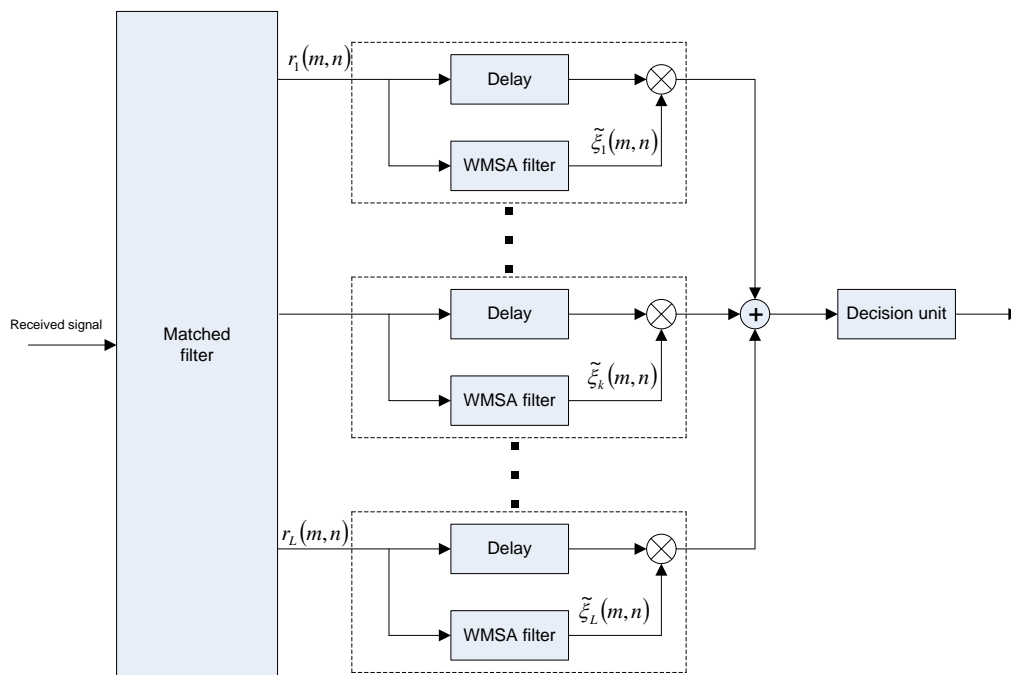

Fig.3. Block diagram of RAKE receiver with WMSA filter

The received signal is despread by a matched filter and resolved into the  $L$  signals that have propagated along different paths with different time delays. The matched filter output at the  $m$ -th symbol position of  $n$ -th basic frame associated with the  $l$ -th path can be represented as [1]:

$$r_l(m, n) = \frac{1}{T} \int_{mT+nT_{slot}+\tau_l}^{(m+1)T+nT_{slot}+\tau_l} r_l(t)g(t-\tau_l)dt = \sqrt{2S}\xi_l(m, n)\exp j\phi_{lm}(m, n) + \rho_l(m, n) \quad (1)$$

where  $g(t) = \{g_m(t), g_{pd}(t), g_{pp}(t)\}$ ,  $\xi_l(m, n) = \xi_l(mT + nT_{slot})$ ,  $\phi_p(m, n) = \phi_p(mT + nN_D)$ ,  $\phi_{lm}(m, n) = \phi_{lm}(mT + n(N_D + N_p))$ , and  $\rho_l(m, n)$  is the noise component. The WMSA filter estimates the value of  $\xi_l(m, n)$  using pilot sequence.  $L$  resolved signals are multiplied by the complex conjugates of  $\xi_l(m, n)$ . The RAKE combiner output at the  $m$ -th data position of  $n$ -th basic frame is therefore represented as [1]:

$$\bar{d}(m, n) = \sum_{l=0}^{L-1} r_l(m, n)\tilde{\xi}_l^*(m, n) \quad (2)$$

Finally, the Rake combiner output is decoded to recover the transmitted data.

The block diagram of WMSA filter is shown on fig. 4 [1], [2].

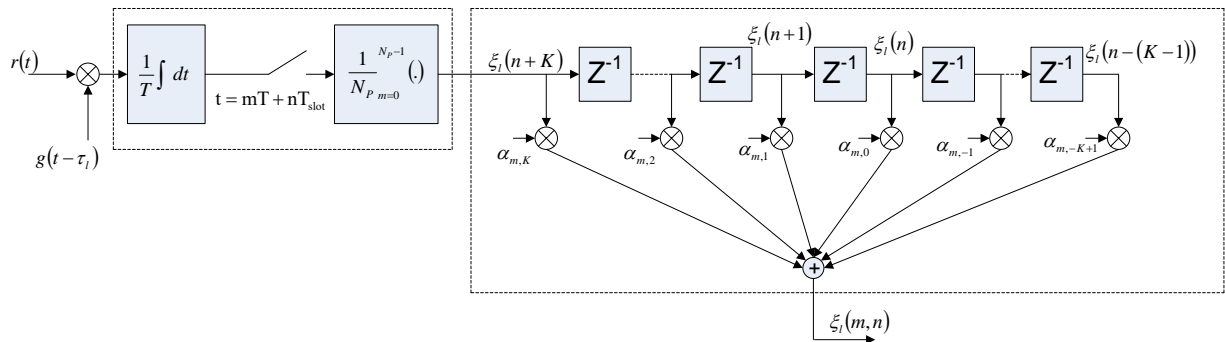

Fig.4. Block diagram of WMSA filter

By adopting a simple assumption that the fading of signals are, at some time, a quasi-stationary, a simple accumulation of successive chains of pilot improves the signal to noise power ratio (SNR) [1], [2]. In that case channel estimation can be written as follow:

$$\hat{\xi}_l(n) = \frac{1}{N_p} \sum_{m=0}^{N_p-1} r_l(m, n)\exp[-j\pi/4] \quad (3)$$

which approximates the instantaneous channel gain at the beginning of the  $n$ -th basic frame of the  $l$ -th path. In case of very slow fading, it is possible to extend the observation interval to several basic frames and coherently add several consecutive instantaneous channel estimates to further increase SNR. However, in general, the channel gain varies frame by frame.

Therefore the instantaneous channel estimates need to be weighted and summed. The filter output is expressed as [1], [2]:

$$\tilde{\xi}_l(m, n) = \sum_{j=-K+1}^K \alpha_{m,j} \hat{\xi}_l(n+j) \quad (4)$$

where  $\alpha_{m,j}$  is the real-valued weighting factor and  $2K$  is the observation interval represented by the number of basic frames. Using the weighted factors  $\alpha_{m,j}$ 's pre-stored in memory, the channel estimates  $\tilde{\xi}_l(m, n)$ 's are easily calculated from equation (4) [1]. In Ref. [2], the weighting factors optimized at the center of the basic frame are used for the reception of all data symbols within the basic frame, that is,  $\alpha_{m,j}$  is constant regardless of symbol position  $m$ . However, in case of fast fading, the channel gain changes even within the basic frame. Consequently, we change the weight factors symbol-by-symbol within the basic frame to better track fast fading. Based on results from [2], the following two types (Type I and II) of weighting factors sets using linear interpolation [1].

Type I:

$$\left\{ \begin{array}{l} \alpha_{m,-2} = 0,5 - 0,5 \cdot \frac{m'}{N_D/2}, \\ \alpha_{m,-1} = 0,75 - 0,15 \cdot \frac{m'}{N_D/2}, \\ \alpha_{m,0} = 1,0 \\ \alpha_{m,1} = 0,75 + 0,25 \cdot \frac{m'}{N_D/2}, \\ \alpha_{m,2} = 0,5 + 0,1 \cdot \frac{m'}{N_D/2}, \\ \alpha_{m,3} = 0, \end{array} \right. \quad \text{if } m' \leq N_D/2, \quad (5)$$

and

$$\left\{ \begin{array}{l} \alpha_{m,-2} = 0, \\ \alpha_{m,-1} = 0,6 - 0,1 \cdot \frac{(m'-N_D/2)}{N_D/2}, \\ \alpha_{m,0} = 1,0 - 0,25 \cdot \frac{(m'-N_D/2)}{N_D/2}, \\ \alpha_{m,1} = 1,0, \\ \alpha_{m,2} = 0,6 + 0,25 \cdot \frac{(m'-N_D/2)}{N_D/2}, \\ \alpha_{m,3} = 0,5 \cdot \frac{(m'-N_D/2)}{N_D/2}, \end{array} \right. \quad \text{if } m' > N_D/2, \quad (6)$$

where  $m' = m - N_p$ ,

Type II:

$$\begin{cases} \alpha_{m,-1} = 0,8 - 0,2 \cdot \frac{m'}{N_D/2} \\ \alpha_{m,0} = 1,0 \\ \alpha_{m,1} = 0,8 + 0,2 \cdot \frac{m'}{N_D/2} \\ \alpha_{m,2} = 0,6 + 0,2 \cdot \frac{m'}{N_D/2} \end{cases} \text{ if } m' \leq N_D/2 \quad (7)$$

and

$$\begin{cases} \alpha_{m,-1} = 0,6 - 0,6 \cdot \frac{(m' - N_D/2)}{N_D/2} \\ \alpha_{m,0} = 1,0 - 0,2 \cdot \frac{(m' - N_D/2)}{N_D/2} \\ \alpha_{m,1} = 1,0 \\ \alpha_{m,2} = 0,6 + 0,2 \cdot \frac{(m' - N_D/2)}{N_D/2} \end{cases} \text{ if } m' > N_D/2 \quad (8)$$

where  $m' = m - N_p$ .

### Simulation investigation

Simulation results are presented in the following charts. Simulation conducted at the following assumptions:

- data transmission 8kb/s
- CRC12 detection coding
- (3,1,9) cycle coding

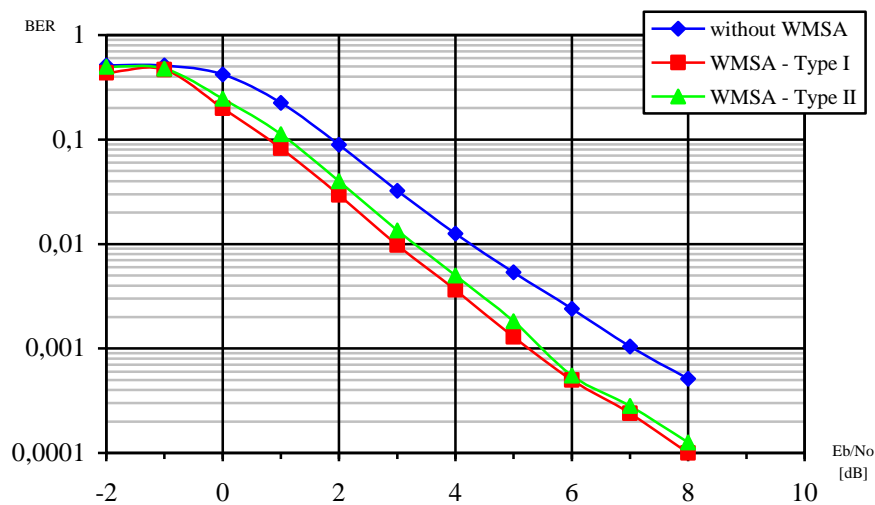

Fig. 5. Simulation results. Object moving at speed 3km/h

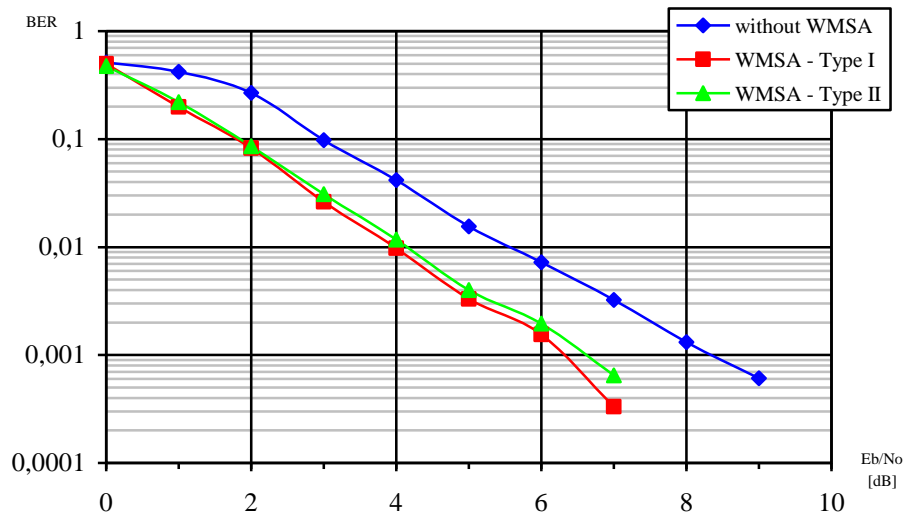

Fig. 6. Simulation results. Object moving at speed 50km/h.

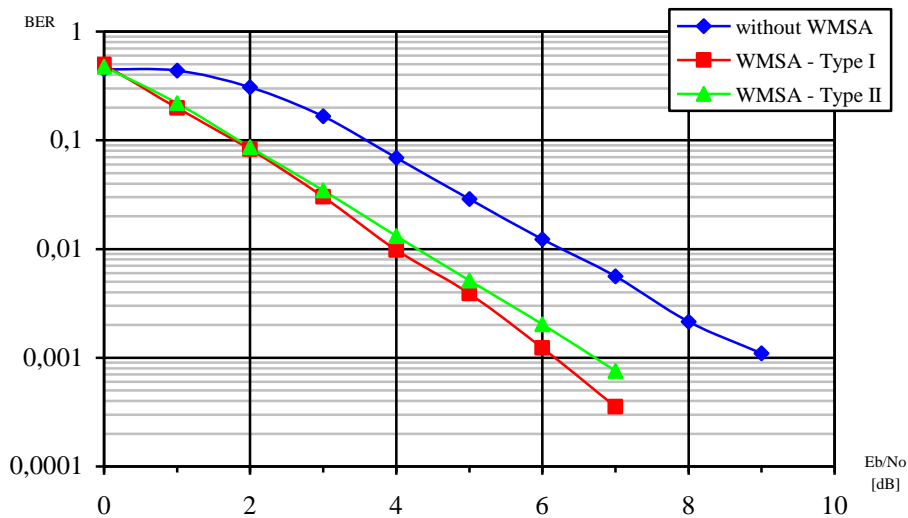

Fig. 7. Simulation results. Object moving at speed 120km/h.

We can draw important conclusions based on results of simulation. Applying Rake receiver with WMSA filter causes that a lower ratio of  $E_b/N_0$  is required to maintain the same rate of errors (BER) [3]. Using Rake receiver improve our signal from 1 to 3 dB. Type I and Type II of a WMSA filter differs only by the number of branches. Type I filter (six branches) shows improvement of 0,1 to 0,3 dB comparing to Type II filter (four branches). With such a simple operation of extending the number of branches in the WMSA filter, there is improvement, that in systems with a dispersed spectrum is significant [3].



## Conclusion

Proposed solutions based on this type of filter as phase estimators (WMSA) can significantly improve the quality of transmission (understood as a reduction in the rate of errors of a given  $S/N$ ). Reducing the rate of error increases the incoming signal reliability. Presented estimator Rake receiver with WMSA filter can be successfully used in navigation systems. It is easy to implement and the improvement achieved through him will be significant.

Described new solutions of the software implementation of the RAKE receiver techniques is funded by the Polish Ministry of Science and Higher Education as a part of research and development project Nr. O R00 0049 06. The authors express their sincere thanks for allocated funds for this purpose.

## References

- [1] SADAYUKI ABETA, MAMORU SAWAHASHI, FUMIYUKI ADACHI: Performance Comparison between Time-Multiplexed Pilot Channel and Parallel Pilot Channel for Coherent Rake Combining in DS-CDMA Mobile Radio, IEICE TRANS. COMMUN., VOL.E81-B, NO.7, pp. 1417-1425, **July 1998**.
- [2] HIDEHIRO ANDOH, MAMORU SAWAHASHI, FUMIYUKI ADACHI: Channel Estimation Filter Using Time-Multiplexed Pilot Channel for Coherent RAKE Combining in DS-CDMA Mobile Radio, IEICE TRANS. COMMUN., VOL.E81-B, NO.7, pp. 1517-1526, **July 1998**.
- [3] SIWICKI WOJCIECH: Multipath RAKE receiver in WCDMA/FDD systems, Master's thesis, PG WETI, Gdańsk **2002**.

