

Stability of a proportional observer with additional integrators on the example of the flux observer of induction motor

Abstract. The paper describes issues connected with stability of a proportional Luenberger observer with additional integrators. It is proven that there exists a class of observed systems for which discussed observer is always unstable, independent of its gains selection. Stability conditions are presented as well. The problem of stability is solved by replacing additional integrators with modified integrators. It is shown that proper selection of parameters of modified integrators and observer's gains ensures its stability for every observed system. Experimental results are also presented, these were obtained for the observer of magnetic fluxes of induction motor.

Streszczenie. W artykule opisano zagadnienia związane ze stabilnością proporcjonalnego obserwatora Luenberga z dodatkowymi integratorami. Udowodniono, że istnieje klasa obiektów obserwowanych, dla których rozważany obserwator jest zawsze niestabilny, niezależnie od doboru jego wzmocnień. Przedstawiono również warunki stabilności. Problem stabilności rozwiązano zastępując dodatkowe integratory integratorami zmodyfikowanymi. Wykazano, że właściwy dobór parametrów zmodyfikowanych integratorów i wzmocnień obserwatora zapewnia jego stabilność dla każdego obiektu obserwowanego. Przedstawiono również wyniki badań laboratoryjnych uzyskane dla obserwatora strumieni magnetycznych silnika indukcyjnego. (Stabilność obserwatora proporcjonalnego z dodatkowymi integratorami na przykładzie obserwatora strumieni magnetycznych silnika indukcyjnego).

Keywords: induction motor, Luenberger observer, stability.

Słowa kluczowe: silnik indukcyjny, obserwator Luenberga, stabilność.

Introduction

Reconstruction of rotor fluxes of induction motor with use of a proportional Luenberger observer is well described in literature [1, 2] and frequently used in practice. The proportional observer requires information about angular speed of the motor, treated as an observer's input. However, measurement noise and other disturbances overlaying motor's speed have crucial impact on reconstruction quality of the observer. This impact can be decreased with introduction of additional integrators into the structure of proportional observer [3]. Then signals corresponding to noises overlaying motor's speed are treated as unmeasured inputs.

Observed system

A bilinear time-invariant dynamic system with unmeasured inputs can be described with a set of matrix equations using dimensionless quantities [2], consisting of differential state equation (1) and algebraic output equation (2):

$$(1) \quad t_b \dot{x} = \left(A + \sum_{i=1}^p u_i A_i \right) x + B_1 d + B_2 u$$

$$(2) \quad y = Cx$$

where: $x \in R^n$ – state vector, $u \in R^p$ – input vector, $y \in R^q$ – output vector, $d \in R^r$ – disturbance (unmeasured input) vector, A, A_i, B_1, B_2 and C – real matrices of appropriate size whose elements have constant values, u_i – the i -th element of vector u , t_b – base time.

Observer with additional integrators

State variables of a system described with equations (1) and (2), covered by vector x , may be reconstructed with use of a bilinear time-invariant proportional Luenberger observer with additional integrators [3, 4, 5], described with equation (3):

$$(3) \quad \begin{aligned} t_b \hat{x} = & \left(A + \sum_{i=1}^p u_i A_i \right) \hat{x} + B_2 u + K(C\hat{x} - y) + \\ & + B_1 K_\nu \frac{1}{t_b} \int_0^t (C\hat{x} - y) d\tau + \\ & + B_1 K_{\nu-1} \frac{1}{t_b^2} \int_0^t \int_0^t (C\hat{x} - y) d\tau^2 + \dots \\ & \dots + B_1 K_1 \frac{1}{t_b^\nu} \underbrace{\int_0^t \dots \int_0^t}_{\nu} (C\hat{x} - y) d\tau^\nu \end{aligned}$$

where: \hat{x} – reconstructed state vector x , K, K_i – real gain matrices of appropriate size, ν – number of additional integrators. Block diagram corresponding to equation (3) is shown in the figure 1.

The error equation of the observer [3, 6] can be written as following (inputs connected with disturbances omitted):

$$(4) \quad t_b \dot{\varepsilon} = E(u)\varepsilon$$

where: ε – error vector, $E(u)$ – state matrix of the observer determining its stability and dynamical properties, given as:

$$(5) \quad E(u) = \hat{A}(u) + \hat{K}\hat{C}$$

where:

$$(6) \quad \hat{A}(u) = \begin{bmatrix} A + \sum_{i=1}^p u_i A_i & \mathbf{0}_{n \times z(\nu-1)} & B_1 \\ \mathbf{0}_{z \times n} & \mathbf{0}_{n \times z(\nu-1)} & \mathbf{0}_{z \times z} \\ \mathbf{0}_{z(\nu-1) \times n} & I_{z(\nu-1)} & \mathbf{0}_{z(\nu-1) \times z} \end{bmatrix}$$

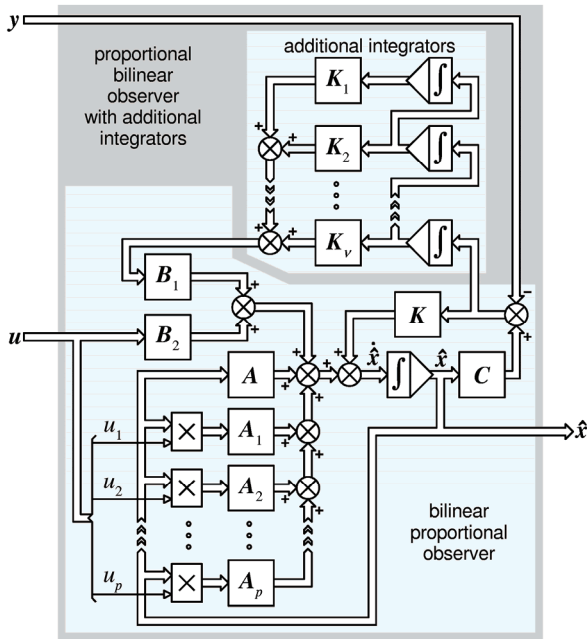

Fig. 1. Block diagram of the observer

$$(7) \quad \hat{K} = \begin{bmatrix} K^T & K_1^T & \dots & K_v^T \end{bmatrix}^T, \quad \hat{C} = \begin{bmatrix} C & \mathbf{0}_{q \times z} \end{bmatrix}$$

As $\mathbf{0}_{z \times n}$ is denoted z -row, n -column null matrix and as I_n is denoted identity matrix of n -th rank.

Selection of observer parameters consists in such setting values of elements of all gain matrices K , that all eigenvalues of matrix E are placed in the left part of complex plane (their real parts are negative). When this condition is not met the observer is unstable.

Induction motor as an observed system

The discussed mathematical model of squirrel-cage induction motor is described with four differential equations for stator and rotor windings, written in stator winding oriented α - β Cartesian coordinate system [7]:

$$(8) \quad t_b \dot{\psi}_{sa} + R_s i_{sa} = u_{sa}$$

$$(9) \quad t_b \dot{\psi}_{s\beta} + R_s i_{s\beta} = u_{s\beta}$$

$$(10) \quad t_b \dot{\psi}_{ra} + \omega \psi_{r\beta} + R_r i_{ra} = 0$$

$$(11) \quad t_b \dot{\psi}_{r\beta} - \omega \psi_{ra} + R_r i_{r\beta} = 0$$

and four algebraic equations:

$$(12) \quad \psi_{sa} = L_s i_{sa} + L_m i_{ra}$$

$$(13) \quad \psi_{s\beta} = L_s i_{s\beta} + L_m i_{r\beta}$$

$$(14) \quad \psi_{ra} = L_r i_{ra} + L_m i_{sa}$$

$$(15) \quad \psi_{r\beta} = L_r i_{r\beta} + L_m i_{s\beta}$$

where: $u_{sa}, u_{s\beta}$ – stator winding's voltages; $i_{sa}, i_{s\beta}, i_{ra}, i_{r\beta}$ – stator and rotor windings' currents; $\psi_{sa}, \psi_{s\beta}, \psi_{ra}, \psi_{r\beta}$ – magnetic fluxes coupled with stator and rotor windings; $R_s,$

R_r, L_s, L_r, L_m – parameters of the equivalent diagram of induction motor.

Mathematical model of the motor was transformed to state equations for (1) and (2), with assumption of following forms of state, input and output vectors:

$$(16) \quad \mathbf{x} = \begin{bmatrix} \psi_{sa} & \psi_{s\beta} & \psi_{ra} & \psi_{r\beta} \end{bmatrix}^T$$

$$(17) \quad \mathbf{u} = \begin{bmatrix} u_{sa} & u_{s\beta} & \omega \end{bmatrix}^T$$

$$(18) \quad \mathbf{y} = \begin{bmatrix} i_{sa} & i_{s\beta} \end{bmatrix}^T$$

Taking into consideration noises $\delta\omega$ overlaying motor's angular speed ω and equations (10) and (11), disturbance vector is defined as:

$$(19) \quad \mathbf{d} = \begin{bmatrix} -\psi_{ra} \delta\omega & \psi_{r\beta} \delta\omega \end{bmatrix}^T$$

For discussed model of the motor $n=4, p=3, q=z=2$, matrices A, A_i, B_1, B_2 and C have element values dependent only on parameters of the motor's equivalent circuit. In particular:

$$(20) \quad A = \gamma \begin{bmatrix} R_s L_r I_2 & -R_s L_m I_2 \\ -R_r L_m I_2 & R_r L_s I_2 \end{bmatrix}, \quad B_1 = \begin{bmatrix} \mathbf{0}_{2 \times 2} \\ J \end{bmatrix}$$

$$(21) \quad A_1 = A_2 = [0]_{4 \times 4}, \quad A_3 = \begin{bmatrix} \mathbf{0}_{2 \times 2} & \mathbf{0}_{2 \times 2} \\ \mathbf{0}_{2 \times 2} & J \end{bmatrix}$$

$$(22) \quad C = \gamma \begin{bmatrix} -L_r I_2 & L_m I_2 \end{bmatrix}$$

where:

$$(23) \quad \gamma = (L_m^2 - L_s L_r)^{-1}, \quad J = \begin{bmatrix} 0 & -1 \\ 1 & 0 \end{bmatrix}$$

Stability of the observer

Asymptotical stability of the observer can be provided only when observer's state matrix E is non-singular. However, for induction motor described with matrices from (20) to (22), the rank of matrix E is always less than number of its rows. Matrix E consists of a sum of matrix \hat{A} and product of matrices \hat{K} and \hat{C} (5). Given the form of matrix \hat{A} (6), it always has $z=2$ rows filled with zeros. Maximal rank of product of matrices \hat{K} and \hat{C} is equal to their lowest size $q=2$, which is why this product contains only two linearly independent rows. From (7) and (22) comes that any i -th row of this product can be written as:

$$(24) \quad \begin{bmatrix} \sum_{j=1}^q k_{i,j} c_{j,1} & \dots & \sum_{j=1}^q k_{i,j} c_{j,m} & \dots & \sum_{j=1}^q k_{i,j} c_{j,n+z} \end{bmatrix} = \\ = \gamma \begin{bmatrix} -k_{i,1} L_r & -k_{i,2} L_r & k_{i,1} L_m & k_{i,2} L_m & \underbrace{0 \dots 0}_{2v} \end{bmatrix}$$

where k_{ij} and $c_{j,m}$ are corresponding elements of matrices \hat{K} and \hat{C} . The final form of the product's i -th row is a

linear combination of the first two rows of matrix \hat{A} , which results from (6), (20) and (21). Therefore product of matrices \hat{K} and \hat{C} doesn't increase the rank of matrix E , which remains singular.

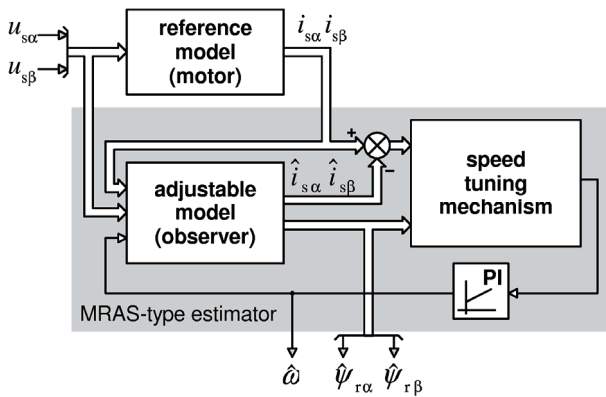

Fig.2. Block diagram of MRAS-type estimator for angular speed and magnetic fluxes reconstruction

It is proven that observer's state matrix E for induction motor is always singular and has at least $z = 2$ eigenvalues equal to zero, which is why the observer is unstable.

Generally, for every observed system, the observer with additional integrators is always unstable when following inequality is true [6]:

$$(25) \quad \text{rank} \begin{pmatrix} A + \sum_{i=1}^p u_i A_i & B_1 \\ C & \mathbf{0}_{q \times z} \end{pmatrix} < n + z$$

Stability of the observer can be provided by replacing additional integrators with modified integrators, described with state equation [6, 8]:

$$(26) \quad t_b \dot{g} = h - \omega_c g$$

where as g and h are correspondingly denoted integrator's output and input signals, as ω_c is denoted integrator's cut-off frequency. Application of modified integrators is also necessary in order to prevent the observer from dc-offset accumulation [4, 6]. Integrators described with equation (26) have an impact on the form of matrix E , since by introducing additional non-zero elements they increase its rank. New form of matrix E can be written as:

$$(27) \quad \hat{E}(u) = E(u) - \begin{bmatrix} \mathbf{0}_{n \times n} & \mathbf{0}_{n \times z} & \cdots & \mathbf{0}_{n \times z} \\ \mathbf{0}_{z \times n} & \omega_{c1} \mathbf{I}_z & \cdots & \mathbf{0}_{z \times z} \\ \vdots & \vdots & \ddots & \vdots \\ \mathbf{0}_{z \times n} & \mathbf{0}_{z \times z} & \cdots & \omega_{cv} \mathbf{I}_z \end{bmatrix}$$

where as ω_{ci} is denoted the cut-off frequency of i -th additional integrator. Inequality (25) assumes new form as well:

$$(28) \quad \text{rank} \begin{pmatrix} A + \sum_{i=1}^p u_i A_i & B_1 \\ C & \mathbf{0}_{q \times z} \end{pmatrix} < n$$

Assuming that the state matrix of observed system $\left(A + \sum_{i=1}^p u_i A_i \right)$ is non-singular, inequality (28) is always false, therefore the stability of the observer may always be ensured and depends only on its gains selection.

Experimental results

Laboratory investigation was performed at the Technical University of Gdańsk, at the laboratory of the Department of Automatics of Electric Drives.

Discussed observer was applied to reconstruction of magnetic fluxes of induction motor operating in multiscalar control system [9, 10, 11]. Squirrel-cage induction motor, type AAUZD, rated at 3 kW was used, fed with voltage inverter. The observer operates as an adjustable model in the structure of MRAS estimator [12], reconstructing motor's angular speed (fig.2).

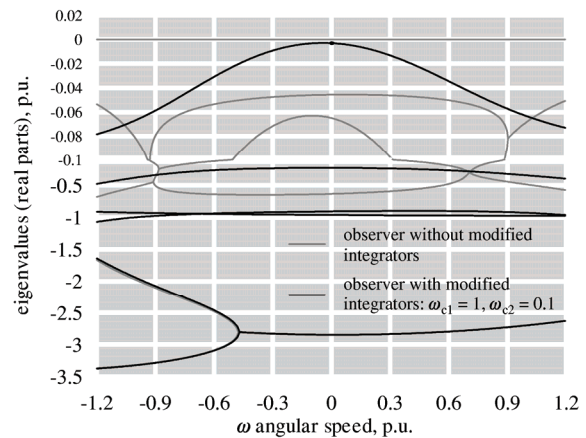

Fig.3. Eigenvalues of proportional observer with two additional integrators with and without modified integrators

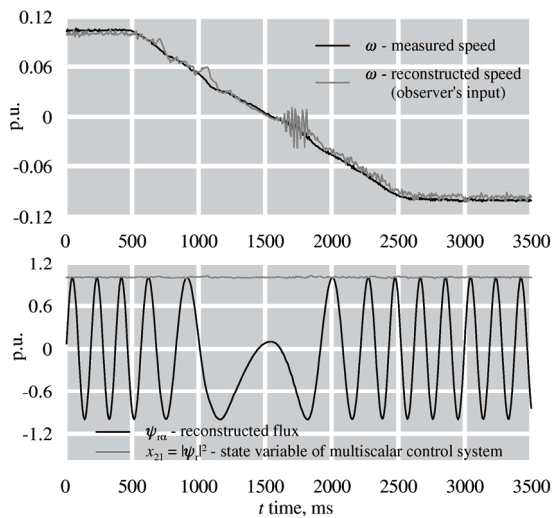

Fig.4. Experimental results obtained during reversal of the motor

One of observer's inputs is the speed reconstructed by the estimator. In order to decrease the impact of speed reconstruction errors on the operation of the observer, two additional integrators ($z = 2$) were introduced into its structure.

Comparison of properties of the observer before and after application of modified integrators is shown in the figure 3. The most important difference between them is that the observer without modified integrators has two

eigenvalues with real parts equal to zero, what makes it unstable.

During experimental researches reversal of the motor was performed at the low speed, equal to 10% of nominal motor's speed. Recorded transients are shown in the figure 4. Comparison of the reconstructed angular speed with the measured one shows the rate of noises included in its transient. However speed noises have little impact on rotor flux reconstruction quality, which is good enough to provide proper operation of the control system. In particular, value of the state variable x_{21} [9] is properly stabilized by the control system and remains constant.

Conclusions

Introduction of additional integrators into the structure of proportional observer of magnetic fluxes of the induction motor increases its immunity to noises overlaying its input angular speed. Application of modified integrators in the structure of observer with additional integrators is necessary in order to provide its stability.

REFERENCES

- [1] Kubota H., Matsuse K., Nakano T., New adaptive flux observer of induction motor for wide speed range motor drives, *16th Conf. of IEEE Industrial Electronics Society IECON*, Pacific Grove 1990, 921-926
- [2] Orłowska-Kowalska T., Bezczujnikowe układy napędowe z silnikami indukcyjnymi, *Oficyna Wydawnicza Politechniki Wrocławskiej*, Wrocław 2003
- [3] Guo-Ping J., Suo-Ping W., Wen-Zhong S.: Design of observer with integrators for linear systems with unknown input disturbances, *Electronics Letters*, 36 (2000), No. 13, 1168-1169
- [4] Białoń T., Lewicki A., Niestrój R., Pasko M., Badania porównawcze obserwatorów z dodatkowymi integratorami w estymatorze typu MRAS strumieni magnetycznych i prędkości obrotowej silnika indukcyjnego, *Przegląd Elektrotechniczny*, 86 (2010), nr 2, 101-106
- [5] Białoń T., Pasko M., Zastosowanie obserwatora rozszerzonego do odtwarzania elektromagnetycznych strumieni sprzężonych i prędkości obrotowej silnika indukcyjnego, *Przegląd Elektrotechniczny*, LXXXI (2005), nr 1, 13-17
- [6] Białoń T., Zastosowanie obserwatorów Luenbergera do odtwarzania zmiennych stanu silnika indukcyjnego, PhD thesis, Silesian University of Technology, Gliwice 2010, full text available at <http://delibra.bg.polsl.pl>
- [7] Paszek W., Dynamika maszyn elektrycznych prądu przemiennego, *Helion*, Gliwice 1998
- [8] Hu J., Wu B., New Integration Algorithms for Estimating Motor Flux over a Wide Speed Range, *IEEE Trans. on Power Electronics*, 13 (1998), No. 5, 969-977
- [9] Białoń T., Lewicki A., Pasko M., Badania obserwatorów proporcjonalnych w multiskalarnym układzie sterowania silnika indukcyjnego, *Przegląd Elektrotechniczny*, LXXXIV (2008), nr 9, 105-108
- [10] Krzemiński Z., Lewicki A., Włas M., Properties of control systems based on nonlinear models of the induction motor, *EPNC*, Poznań 2004, 24-26
- [11] Krzemiński Z., Nonlinear control of induction motor, *Proceedings of the 10th IFAC World Congress*, Munich 1987, 349-354
- [12] Niestrój R., Lewicki A., Białoń T., Pasko M., Odtwarzanie strumieni magnetycznych i prędkości obrotowej silnika indukcyjnego przy użyciu estymatora typu MRAS z obserwatorem Luenbergera w roli modelu adaptacyjnego, *XLV SME*, Rzeszów – Krasice 2009, 23-26

Autorzy: dr inż. Tadeusz Białoń, Politechnika Śląska, Instytut Elektrotechniki i Informatyki, Zakład Maszyn Elektrycznych i Inżynierii Elektrycznej w Transporcie, ul. Akademicka 10a, 44-101 Gliwice, E-mail: tadeusz.bialon@polsl.pl; dr inż. Arkadiusz Lewicki, Politechnika Gdańska, Katedra Automatyki Napędu Elektrycznego, ul. Sobieskiego 7, 80-216 Gdańsk, E-mail: alewicki@ely.pg.gda.pl; mgr inż. Roman Niestrój, Instytut Elektrotechniki i Informatyki, Zakład Maszyn Elektrycznych i Inżynierii Elektrycznej w Transporcie, ul. Akademicka 10a, 44-101 Gliwice, E-mail: roman.niestroj@polsl.pl; prof. dr hab. inż. Marian Pasko, Politechnika Śląska, Instytut Elektrotechniki i Informatyki, Zakład Maszyn Elektrycznych i Inżynierii Elektrycznej w Transporcie, ul. Akademicka 10a, 44-101 Gliwice, E-mail: marian.pasko@polsl.pl