Strategic Flexibility as a Mediator in Relationship between Managerial Decisions and Organizational Learning: Ambidexterity Perspective

Submitted 11/08/20, 1st revision 12/09/20, 2nd revision 03/10/20, accepted 30/10/20

Monika Stelmaszczyk¹, Agata Pierscieniak²

Abstract:

Purpose: The purpose of the article is to determine strategic flexibility in the relationship between managerial decisions and organizational learning. The analyses are conducted in the ambidexterity convection.

Design/Methodology/Approach: The study was conducted at a textile company. The company is a leader in the textile recycling industry in Poland. Empirical data were collected using the PAPI technique. The survey questionnaire was addressed to all 138 company managers. The response rate was 57%. Linear regression analyses were performed to test the research hypotheses. The significance of indirect effects was checked using the bootstrap method.

Findings: Our findings show that as the ambidexterity oriented managerial decisions increases, the organizational learning ambidexterity increases. This relationship mediates strategic flexibility through variable flexibility resources and flexibility coordination. In fact, we have indicated the effect of double mediation. This means that there is a relationship between the independent variable and the dependent variable because of interacting resource flexibility and coordination flexibility.

Practical Implications: Our study shows that managerial decisions in the company will become more conducive for improving current ideas and introducing new ideas, including ways of their implementation if the enterprise undertakes the proposed steps. They include the acquisition of resources, to develop practical skills, to care in maintaining relatively low costs and shortening task execution duration, to be able to switch to alternative uses of resources.

Originality/Value: The value of our research is gaining new knowledge about strategic flexibility. Arguing its necessity for the existence of relationships between managerial decisions and organizational learning, using the ambidexterity convention, improves the knowledge regarding the identity of this category of flexibility.

Keywords: Strategic flexibility, managerial decisions, organizational learning, ambidexterity.

JEL codes: D18, D83, E22, L10, L20, L81, M10, M12, O34.

Paper type: Research study.

Acknowledgment: Financial support from research project no. SMGR.RN.20.072 538 by the Jan Kochanowski University in Poland is gratefully acknowledged.

¹Jan Kochanowski University in Kielce, Poland, Department of Management,
e-mail: m.stelmaszczyk@ujk.edu.pl;

²Gdańsk University of Technology, Poland, Faculty of Management and Economics
e-mail: agata.pierscieniak@gmail.com;

1. Introduction

The development of management sciences allows the identification and analysis of the organization's market behavior from the perspective of processes and phenomena that are causal. Such processes and phenomena are treated as mechanisms leading to the expected effects, e.g., competitive advantage (Grzebyk and Kryński, 2011). To achieve it, modern organizations must make decisions that are the domain of the managerial staff. However, modern organizations operating in the knowledge-based economy absorb this knowledge themselves (Stelmaszczyk, 2020). This process, called organizational learning in subject literature, has been theoretically developed since the 1960s (Cyert and March, 1963). It is not easy to define as routine-based, history-dependent, and target-oriented (Levitt and March, 1988). This abstract construction is understood, *inter alia*, as a process (Levinthal and March, 1993), thought changes (Schulz, 2002), or behavioral changes (Schilling and Kluge, 2009).

The lack of an unambiguous definition indicates that this is still a relatively new field that has not yet developed common terminologies. In analyzing its development in literature, one can observe that organizational learning is combined with the organization's decision-making processes. Argyris and Schön (1978) proposed a general theory of organizational learning as part of enterprise decision making. In their work, they strongly emphasized the role of rules, procedures, and organizational routines that are a tool for adapting to the environment and a way for the organization to remember effective action (Olejniczak, Płoszaj, and Rok, 2012).

Strategic flexibility is another interesting theoretical construct that is increasingly popular in contemporary organizational research. Its complex identity is increasingly being analyzed as a mediating factor in relations between various phenomena and organizational processes, e.g., in the relationship between commitment to employees and service firms (Roca-Puig *et al.*, 2005). This research trend inspired the authors to define the role of strategic flexibility in the relationship between managerial decisions and organizational learning. We want to identify existing relationships between both, based on the concept of ambidexterity while considering both current (operational activities) and future (exploratory activities) perspectives in the organization's functioning.

The purpose of the article is to determine the role of strategic flexibility in the relationship between decisions made by managers and organizational learning, as analyzed in the ambidexterity convention. The work adopts a multi-level approach that analyzes relationships between constructs at the individual and organizational levels (Raisch *et al.*, 2009).

The paper is structured as follows. In the second part, a brief characteristic of a flexible strategy and the ambidexterity concept was undertaken. Next, we presented the research model and the analysis based on empirical materials. In section four,



empirical results are presented and discussed. Conclusions are presented in the last part.

2. Strategic Flexibility and Ambidexterity as a Research Category

Strategic flexibility is an attribute particularly desired by every organization (Nadkarni and Narayanan, 2007) and the most important competitive advantage (Barney, 1991). The essence of the concept of "strategic flexibility" is "flexibility" defined as the awareness of the existence (knowledge) of many solutions, as well as the ability and tendency to selectively choose the most appropriate solutions for a given problem and a specific goal (Star and Seifert, 2006). In this complex phenomenon, the "strategic" context is manifested in undertaking actions focused on long-term goals, using the necessary resources. In general, strategic flexibility has been in current literature conceptualized predominantly as a responsive, reactive ability (Brozovic, 2018). According to Shimizu and Hitt (2004), the authors of one of the key definitions of this phenomenon, strategic flexibility treated as the ability of an organization to identify major changes occurring in the external environment, viewed from two aspects, namely rapid allocation of resources to new lines of action and rapid response to termination or withdrawal of resource commitments.

The proposed definitions and analyses of other researchers (Sanchez, 1997) show that strategic flexibility is a complex category. We should identify it with two dimensions: resource flexibility as well as coordination flexibility. Both categories are diagnosed at the organizational level, despite the difference in their nature. Resource flexibility is treated as a feature of resources. It is determined by the scope of alternative applications of specific resources, their availability, costs, and time associated with preparing them for alternative use (Stelmaszczyk, 2020). Flexibility in coordination is a feature of the organization. It is identified with the ability to apply existing resources in a new field, coordinate the process of resource transformation at low costs and in a short time, as well as develop new opportunities to quickly adapt to any uncertain environment (Liu, 2009).

The concept of ambidexterity is another research category. It is a new trend in strategic management. Still, it also demonstrates the maturity of researchers who are aware of two different contexts of activities existing side-by-side in the organization. One of the precursors in using this approach was March (1991). He developed this theory by analyzing the internal tension existing in the organization between the strategy of using existing knowledge (exploitation) and the search for new solutions (exploration). Other researchers define organizational ambidexterity as the capacity to simultaneously achieve alignment and adaptability at a defined business level (Gibson and Birkinshaw, 2004). It amounts to performing mutually exclusive activities simultaneously (Gibson and Birkinshaw, 2004) and seeking a balance between them (O'Reilly and Tushman, 2008). It allows one to analyze related activities while remaining in constant tension (Stelmaszczyk and Jarubas, 2019). Raisch *et al.* (2009) noticed that the concept of ambidexterity could be used both at



the organizational level, where organizational mechanisms are analyzed and at the individual level, where we examine the individual's ability to act in a specific current and future context. We will use this approach to analyze organizational learning and managerial decisions that we want to examine. We assume that organizational learning includes exploring new areas of knowledge and exploiting existing ones.

Therefore, organizational learning ambidexterity relies on the simultaneous implementation of exploitative learning and exploratory learning and the search for a balance between them. In turn, ambidexterity managerial oriented decisions are the ability of managers to make alignment-oriented decisions and adaptability-oriented decisions, which are important for an organization's proper functioning that aims to maintain its competitive position.

3. Research Methodology

3.1 Research Hypotheses

As we showed in the introduction, contemporary competitiveness is associated with two key elements: managerial decisions, a management tool, and organizational learning necessary to create competitive advantages. This relationship is noticeable in the literature and seems to be intuitive. To confirm it, we formulated the first research hypothesis, H1 as follows:

H₁: There is a positive relationship between ambidexterity managerial oriented decisions and organizational learning ambidexterity.

Every relationship is true, influenced by various factors, strengthening, weakening, moderating, or mediating its intensity. We assume, for considerations of this paper, that the aforementioned strategic flexibility, which is more often presented as a mediator in enterprise occurring relations (Roca-Puig *et al.* 2005), has, in our case, an intermediary meaning in creating the relationship. Thus, based on the studies conducted, we have assumed that both resource flexibility (RF) and coordination flexibility (CF) have such impacts. The observed relationships are contained in the second hypothesis, H2 as follows:

H₂: Resource flexibility and coordination flexibility are mediators in the relationship between ambidexterity managerial oriented decisions and organizational learning ambidexterity.

A theoretical model was built for the needs of empirical research. It includes three types of variables and relationships that exist between them. The dependent variable is organizational learning ambidexterity (OLA), while the independent variable is ambidexterity managerial oriented decisions (AMD). The two dimensions considered for strategic flexibility are the mediators (SF): resource flexibility (RF) and coordination flexibility (CF) (Figure 1). Our study assumes that organizational



learning ambidexterity is based on the concurrent implementation of exploitative (EdOL) learning and exploratory learning (EnOL). We define exploitative learning as updating and improving the knowledge that an organization already has to improve current (existing) methods and operation concepts. Exploratory learning is the search for new knowledge and using it in the organization's practice by introducing completely new procedures, processes, methods, and undertaking completely new activities.

Ambidexterity managerial oriented decisions involve managers taking alignment (AIMD) and adaptability-oriented decisions (AMD). Alignment-oriented decisions adjust the implementation of the company's goals to the resources they possess and costs. They integrate internal activities so that resources are not wasted and that the assumed costs are not exceeded. Adaptability-oriented decisions enable the organization to react quickly to changes in the environment. Managers making such decisions are more open to new ideas, experimenting with new solutions, and questioning outdated solutions. In turn, we understand resource flexibility as the possibility of using a given resource for alternative use in the shortest possible time and at low costs (resource feature). On the other hand, the flexibility of coordination consists of the organization's ability to use the existing resource in a new way, use the newly acquired resource in practice, and create new combinations of old and new resources (an organization trait).

Figure 1. Conceptual model of research

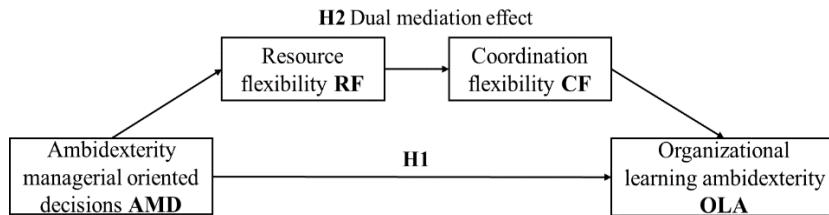

Source: Own elaboration.

3.2 Sample and Data Collection

The study was conducted at VIVE Textile Recycling Sp. Z o. o. The company deals in the acquisition, sorting, and processing of used clothing. It is a leader in the textile recycling industry in Poland. It has a network of 33 brand stores with used clothing. It is also the country's largest importer of this category of clothing. It exports its products to over 80 countries from Western Europe, the Commonwealth of Independent States, Asia, and Africa. The survey research method was used. The PAPI technique was used to collect empirical data (Paper and Pen Personal Interview). The research tool was a structured and standardized questionnaire. It uses a seven-point Likert scale. To measure ambidexterity managerial oriented decisions, a scale developed by Kortmann was adopted (2015). Organizational learning ambidexterity was measured using a scale by Atuahene-Gima and Murray (2007).

The method of measuring these variables was consistent with the combined ambidexterity (Zakrzewska-Bielawska, 2018). On the other hand, strategic flexibility was measured using the scale proposed by Zhou and Wu (2010). Questionnaire interviews were conducted between May and June 2019. The survey questionnaire was addressed to 138 respondents. They were persons holding managerial functions in Vive Textile Recycling Sp. Z o.o. After discarding questionnaires with missing data and unexplainable answers, 78 valid responses were obtained. The response rate was 57%.

Statistical analysis was performed to test the hypotheses. IBM SPSS Statistics version 25 was used. The analysis of empirical material was carried out in two stages. The first stage consisted of verification of measuring tools, where the theoretical validity and reliability of the tools used in the study were checked. In the first step, the tools' relevance was determined using confirmatory factor analysis (CFA). This confirmed the theoretical structure of the tools used by matching it to the data. In other words, it was checked whether a given indicator measures the assumed variable.

Additionally, we calculated the reliability of the convergent validity using the average variance extracted (AVE). It was used to assess the coherence of indicators used for measuring individual variables. Their uniqueness is conditioned on the consistency of the outcomes of the measurements. It should be emphasized that the minimum acceptable value of this indicator is 0.5. In the second step, the reliability of the measurement for each variable and their individual dimensions was determined using two measures, Cronbach's coefficient, and composite reliability – CR. The minimum acceptable value for both measures is 0.7. CR and AVE are chosen as the main indicators by which the validation of tools tested, using a conformational factor analysis can be determined. In the second step, two types of analyses were performed to test the mediation model. First, simple linear regression analyses were performed, using the Hayes and Preacher macro tool PROCESS. Then, the significance of indirect effects was checked using the bootstrapping method. To interpret the analysis, it was assumed that the significance level α is 0.05.

3.3 Confirmatory Factor Analysis

First, it was checked whether the adopted two-factor structure of the independent variable is correct, relying on the ambidexterity context. A conformational factor analysis was carried out to achieve this purpose. The results show that the ambidexterity managerial oriented decisions model is well matched to the data. [$\chi^2(8) = 11.12$; $p = 0.195$, $CMIN/DF = 1.39$; $GFI = 0.958$; $CFI = 0.991$; $RMSEA = 0.071$, $SRMR = 0.033$]. The lowest factor load value is 0.68, while the highest value is 0.96 (Figure 2).

Figure 2. Standardized regression coefficients based on CFA of ambidexterity managerial oriented decisions

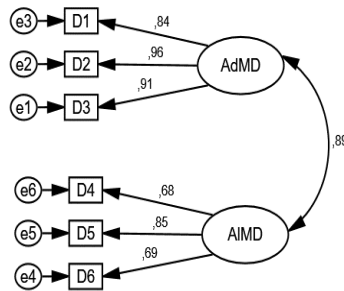

Source: Own study.

Then the two-factor structure of strategic flexibility was checked. After the first analysis, it turned out that the theoretical model adopted was not well-matched to the data [$\chi^2(26) = 85.98$; $p < 0.001$, CMIN/DF = 3.31; GFI = 0.825; CFI = 0.890; RMSEA = 0.173, SRMR = 0.066]. Therefore, based on modification indicators (M.I.), two additional connections were included in the structure of the tool (between positions 1 and 5 and between positions 8 and 9). After considering these relationships, the model became well fitted to the data [$\chi^2(24) = 25.60$; $p = 0.374$, CMIN/DF = 1.07; GFI = 0.931; CFI = 0.997; RMSEA = 0.029, SRMR = 0.039]. The lowest load value is 0.48, while the highest is 0.96 (Figure 3).

Figure 3. Standardized regression coefficients based on CFA of strategic flexibility

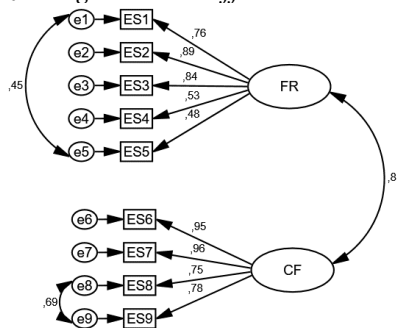

Source: Own study.

In the next step, the propriety of the adopted two-factor organizational learning ambidexterity structure was checked. The theoretical model initially adopted was not well suited to the data [$\chi^2(34) = 61.70$; $p = 0.003$, CMIN/DF = 1.82; GFI = 0.857; CFI = 0.932; RMSEA = 0.103, SRMR = 0.078]. Therefore, item 7 was removed from the model because it was statistically insignificant ($B = 0.25$; $\beta = 0.22$; $t = 1.87$; $p = 0.061$). After excluding it from the EnOL dimension, the model is became well fitted to the data [$\chi^2(26) = 37.58$; $p = 0.066$, CMIN/DF = 1.45; GFI = 0.907; CFI = 0.970; RMSEA = 0.076, SRMR = 0.058]. The lowest load value is 0.62, while the highest is 0.90 (Figure 4).

Figure 4. Standardized regression coefficients based on CFA of organizational learning ambidexterity

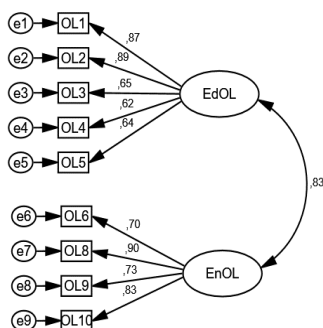

Source: Own study.

Then, based on the value of Cronbach's α coefficient and total reliability coefficient (CR), the reliability of tools measuring individual variables and their dimensions was checked. In addition, convergent validity was calculated using the average extracted variance (AVE) and the average inter-position correlation value. The results are presented in Table 1.

Table 1. Cronbach's alpha, CR and AVE scores

	Cronbach's alpha	Cross correlation	CR	AVE
AMD	0.909	0.634	0.928	0.686
AdMD	0.922	0.806	0.931	0.818
AIMD	0.767	0.530	0.786	0.553
OLA	0.905	0.529	0.926	0.587
EdOL	0.841	0.536	0.858	0.553
EnOL	0.861	0.630	0.871	0.630
SF	0.911	0.535	0.934	0.620
RF	0.848	0.523	0.835	0.517
CF	0.925	0.787	0.921	0.749

Source: Own study.

The analysis showed that a satisfactory reliability level characterizes both the entire tools and their subscales. Both measures take values greater than the minimum level of 0.7. This means that the analyzed constructs are reliable. A satisfactory level of AVE was also observed. In any case, it takes a value greater than the minimum threshold of 0.5. Thus, the accuracy of the adopted constructs is confirmed.

4. Study Results – Mediation Analysis with two Mediators

In the second stage, the mediation model was tested. For this purpose, a number of regressions were performed using the PROCESS macro by Hayes and Preacher, as shown in Figure 5.

Figure 5. Dual mediation effect of resource flexibility and coordination flexibility in the relationship between ambidexterity managerial oriented decisions and organizational learning ambidexterity³

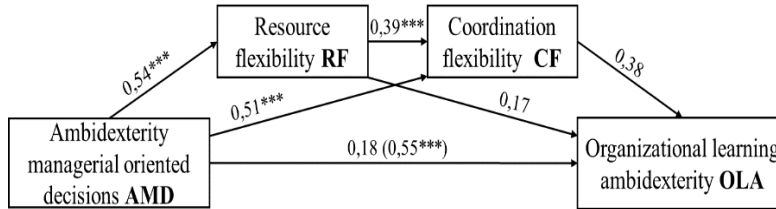

Note: * $p < 0.05$; ** $p < 0.01$; *** $p < 0.001$

Source: Own study.

It turned out that the direct impact of AMD on OLA is positive and statistically significant [$B = 0.68$; $SE = 0.12$; $t(1.76) = 5.73$; $p < 0.001$]. An increase in AMD by one unit causes an increase in OLA level of 0.68 units. R^2 is 0.30 which means that the model explains 30% of the OLA variation. Thus, the H1 hypothesis can be adopted. Another model of statistical analysis, which included two mediation variables (RF and CF), is statistically significant and well matched to the data [$F(3.74) = 18.36$; $p < 0.001$]. In this case, R^2 is 0.43, i.e. the proposed system of variables explains 43% of OLA variance. The relationship between AMD and OLA (taking into account two mediation effects) disappears and becomes statistically insignificant [$B = 0.2$; $SE = 0.16$; $t(3.74) = 1.40$; $p = 0.164$]. This indicates that there is complete mediation.

Additional analysis was also performed on 5000 samplings, using the bootstrap method. Thus, it was confirmed that the double mediation effect is, indeed statistically significant (Table 2). The results of statistical analyses (Figure 5 and Table 2) therefore permit the adoption of hypothesis H2.

Table 2. Total effect and indirect effects

	Effect	Boot SE	Standardized Effect	95% CL (B)	
				LL	UL
Total	0.46	0.18	0.37	0.15	0.85
Ind1	0.11	0.10	0.09	-0.07	0.33
Ind2	0.25	0.13	0.20	0.01	0.51
Ind3	0.10	0.07	0.08	<0.01	0.26
C1	-0.13	0.18	-0.11	-0.50	0.22
C2	0.01	0.13	0.01	-0.27	0.26
C3	0.14	0.09	0.12	-0.01	0.35

Note: Ind1 – AMD>RF>OLA; Ind2 – AMD>CF>OLA; Ind3 – AMD>RF>CF>OLA; C1 – Ind1 minus Ind2; C2 – Ind1 minus Ind3; C3 – Ind2 minus Ind3

Source: Own study.

³At each path unstandardized regression coefficients are shown.

To sum up, the results of the analyses undertaken do not give grounds for rejecting both H1 and H2 hypotheses. This means that they can be considered positively tested.

5. Conclusions

The purpose of our considerations was to determine the role of strategic flexibility in the relationship between ambidexterity managerial oriented decisions and organizational learning ambidexterity. In the examined enterprise, the resources flexibility and coordination flexibility act as mediators of the assumed relationship. Thus, we were able to confirm the existence of the double mediation effect. Therefore, we identified the mechanism thanks to which managerial decisions are made to accomplish current operations and enhance functioning in the face of future changes. This enhances the company's knowledge in improving existing operations and introducing completely new methods and concepts of operation.

Our study shows that managerial decisions at Vive Textile Recycling Sp. Z o. o. will be most favorable to the improvement of current ideas, the introduction of completely new ideas, including ways of their implementation if the enterprise becomes flexible in the context of resources and coordination. Thus, we pointed to the new role of strategic flexibility in the company's operations. In analyzing its nature, it is worth emphasizing that such activities as acquiring resources that will have alternative uses, developing skills for coordinating activities that adapt the organization to changes in the environment, keeping the enterprise competitive by putting new resources and opportunities to practical use, care for the relatively low costs of these activities are important for organizational learning. They mediate the existence of relationships between managerial decisions and organizational learning.

References:

- Argyris, C., Schön, D. 1978. What is an organization that it may learn? Organizational learning: A theory perspective. Addison-Wesley: Reading, MA, 8-29.
- Atuahene-Gima, K., Murray, J.Y. 2007. Exploratory and exploitative learning in new product development: A social capital perspective on new technology ventures in China. *Journal of International Marketing*, 15(2), 1-29.
- Barney, J. 1991. Firm resources and sustained competitive advantage. *Journal of Management*, 17(1), 99-120.
- Brozovic, D. 2018. Strategic flexibility: A review of the literature. *International Journal of Management Reviews*, 20(1), 3-31.
- Cyert, R., March, J. 1963. Behavioral theory of the firm. Englewood Cliffs: Prentice-Hall.
- Gibson, C.B., Birkinshaw, J. 2004. The antecedents, consequences, and mediating role of organizational ambidexterity. *Academy of Management Journal*, 47(2), 209-226.
- Grzebyk, M., Kryński, Z. 2011. Konkurencja i konkurencyjność przedsiębiorstw: ujęcie teoretyczne. *Nierówności Społeczne a Wzrost Gospodarczy*, 20, 107-117.
- Kortmann, S. 2015. The mediating role of strategic orientations on the relationship between ambidexterity-oriented decisions and innovative ambidexterity. *Journal of Product Innovation Management*, 32(5), 666-684.



- Levinthal, D.A., March, J.G. 1993. The myopia of learning. *Strategic Management Journal*, 14(S2), 95-112.
- Levitt, B., March, J.G. 1988. Organizational learning. *Annual Review of Sociology*, 14(1), 319-338.
- Liu, Y., Li, Y., Wei, Z. 2009. How organizational flexibility affects new product development in an uncertain environment: Evidence from China. *International Journal of Production Economics*, 120(1), 18-29. doi: 10.1016/j.ijpe.2008.07.026.
- March, J.G. 1991. Exploration and exploitation in organizational learning. *Organization science*, 2(1), 71-87.
- Nadkarni, S., Narayanan, V.K. 2007. Strategic schemas, strategic flexibility and firm performance. *Strategic Management Journal*, 28(3), 243-270.
- O'Reilly, C.A., Tushman, M.L. 2008. Ambidexterity as a dynamic capability: Resolving the innovator's dilemma. *Research in Organizational Behavior*, 28, 185-206.
- Olejniczak, K., Rok, J., Płoszaj, A. 2012. Organizacyjne uczenie się i zarządzanie wiedzą - przegląd koncepcji, In: Olejniczak, K. (red.), *Organizacje uczące się. Model dla administracji publicznej*. Warszawa: Wydawnictwo Naukowe Scholar, 61-107.
- Raisch, S., Birkinshaw, J., Probst, G., Tushman, M.L. 2009. Organizational ambidexterity: Balancing exploitation and exploration for sustained performance. *Organization science*, 20(4), 685-695.
- Roca-Puig, V., Beltrán-Martín, I., Escrig-Tena, A.B., Bou-Llusar, J.C. 2005. Strategic flexibility as a moderator of the relationship between commitment to employees and performance in service firms. *The International Journal of Human Resource Management*, 16(11), 2075-2093.
- Schilling, J., Kluge, A. 2009. Barriers to organizational learning: An integration of theory and research. *International Journal of Management Reviews*, 11(3), 337-360.
- Schulz, M. 2002. Organizational learning. J.A.C. Baum, ed. *Companion to Organizations*. Blackwell, Oxford, UK, 415-441.
- Shimizu, K., Hitt, M.A. 2004. Strategic flexibility: Organizational preparedness to reverse ineffective strategic decisions. *Academy of Management Perspectives*, 18(4), 44-59.
- Star, J.R., Seifert, C. 2006. The development of flexibility in equation solving. *Contemporary Educational Psychology*, 31(3), 280-300.
- Stelmaszczyk, M. 2020. Wpływ zdolności absorpcyjnej przedsiębiorstwa na jego elastyczność strategiczną. Wyniki badań empirycznych. In: G. Urbanek, S. Grzegorzczak (red.). *Zarządzanie strategiczne w dobie cyfrowej gospodarki sieciowej*. Łódź: Wyd. Politechniki Łódzkiej, 67-79.
- Stelmaszczyk, M. 2020. How absorptive capacity and organizational learning orientation interact to enable innovation capability: an empirical examination. *Entrepreneurial Business and Economics Review*, 8(1), 7-32.
- Stelmaszczyk, M., Jarubas, A. 2019. Podejście ambidexterity w odniesieniu do wymiany wiedzy i ochrony wiedzy w kontekście zdolności absorpcyjnej. *E-Mentor*, 2(79), 68-78.
- Zakrzewska-Bielawska, A. 2018. *Strategie rozwoju przedsiębiorstw. Nowe spojrzenie*. PWE, Warszawa.
- Zhou, K.Z., Wu, F. 2010. Technological capability, strategic flexibility, and product innovation. *Strategic Management Journal*, 31(5), 547-561.

