

TRIESKOVÉ A BEZTRIESKOVÉ OBRÁBANIE DREVA 2020

CHIP AND CHIPLESS WOODWORKING PROCESSES 2020

Vedecký časopis // Scientific journal



TECHNICKÁ UNIVERZITA VO ZVOLENE // TECHNICAL UNIVERSITY IN ZVOLEN
DREVÁRSKA FAKULTA // FACULTY OF WOOD SCIENCES AND TECHNOLOGY
KATEDRA OBRÁBANIA DREVA // DEPARTMENT OF WOODWORKING

Technická univerzita vo Zvolene // **Technical University in Zvolen**
Drevárska fakulta // **Faculty of Wood Sciences and Technology**
Katedra obrábania dreva // **Department of Woodworking**



**TRIESKOVÉ A BEZTRIESKOVÉ
OBRÁBANIE DREVA 2020**

**CHIP AND CHIPLESS
WOODWORKING PROCESSES 2020**

Vedecký časopis // **Scientific journal**



Trieskové a beztrieskové obrábanie dreva (ISSN 2453-904X (print), ISSN 1339-8350 (online)) je vedecký časopis uverejňujúci recenzované pôvodné vedecké práce, z oblasti technického a technologického výskumu trieskového delenie a obrábanie dreva, procesu tvorby triesky, kvality vytváraného povrchu a fyzikálno-mechanických vlastnostiach triesky. Súčasťou zamerania časopisu je i problematika termickej a hydrotermickej úpravy drevnej hmoty teplom a realizácie týchto procesov. Časopis vychádza s dvojročnou periodicitou v elektronickej a printovej forme.

Chip and chipless woodworking processes (ISSN 2453-904X (print), ISSN 1339-8350 (online)) is a scientific journal publishing the reviewed original scientific works focusing on the technical and technological research of chip separation and wood processing, the process of making chips, the quality of created surface as well as the physico-mechanical chips characteristics. The journal focuses also on the issue of thermal and hydrothermal modification of the wood pulp by heat and how these processes are realized. The journal is published in a two-year periodicity in an electronic and a print form.

Redakčná rada/Editorial Board

Predseda redakčnej rady/Editorial Board Chief

Ladislav DZURENDA

Členovia edičnej rady/Editorial Board Members

Vladimír GOGLIA, Zhivko GOCHEV, Mikuláš SIKLIENKA, Kazimierz A. ORLOWSKI, Grzegorz KOWALUK, Alena OČKAJOVA, Miroslav KOPECKY

Zodpovední vedeckí redaktori/Responsible scientific editors

Ladislav DZURENDA

Adrián BANSKI

Technický redaktor/Technical Editor

Silvia NEMCOVA

Redakcia/Editorial office

Technická univerzita vo Zvolene/ Technical university in Zvolen

Drevárska fakulta/ Faculty of Wood Sciences and Technology

Katedra obrábania dreva/ Department of Woodworking

T. G. Masaryka 24

960 01 Zvolen

Vydavateľ/Publisher

Technická univerzita vo Zvolene/Technical university in Zvolen,

T. G. Masaryka 24

960 01 Zvolen, IČO 00397440, 2020

Náklad (Circulation) 80 výtlačkov, rozsah (Pages) 117 strán

Tlač (Printed by) Vydavateľstvo Technickej univerzity vo Zvolene.

Vydanie I. – september

Periodikum s periodicitou raz za dva roky.

Za vedeckú úroveň tejto publikácie zodpovedajú autori.

Všetky práva vyhradené. Nijaká časť textu ani ilustrácie nemôžu byť použité na ďalšie šírenie akoukoľvek formou bez predchádzajúceho súhlasu autorov alebo vydavateľa.

© Technická univerzita vo Zvolene

ISSN 2453-904X (print), ISSN 1339-8350 (online)



OBSAH / CONTENTS

Andrejko Michal – Kúdela Jozef – Mišíková Olga – Kminiak Richard: Štúdium morfológie povrchu dubového dreva po opracovaní gravírovacím CO ₂ laserom <i>Oak wood surface morphology inspected after engraving with a CO₂ laser</i>	5
Banski Adrián – Dudiak Michal: Energetická náročnosť procesu teplovzdušného sušenia brezových vlysov v komorových sušiarňach bez zmeny farby dreva <i>Energy demanding of the process of heat drying of birch friezes in chamber dryers without changing the wood color</i>	15
Deliiski Nencho – Dzurenda Ladislav – Trichkov Neno: An approach for estimating of the natural color change of logs subjected to thermal treatment	21
Deliiski Nencho – Trichkov Neno – Tumbarkova Natalia – Angeski Dimitar – Gochev Zhivko: Computing the average mass temperature of logs and the rate of its change during logs' freezing	29
Dudiak Michal – Dzurenda Ladislav: Acidita (pH) termicky a hydrotermicky upravovaného bukového dreva <i>Acidity (pH) of thermally and hydrothermally treated beech wood</i>	37
Dzurenda Ladislav: Teplovzdušné sušenie parených brezových vlysov v komorových sušiarňach pri zachovaní farby nadobudnutej procesom parenia <i>Hot air drying of steamed birch fairs in chamber dryers when preservation the color acquired by the steaming process</i>	41
Geffert Anton – Geffertová Jarmila – Dudiak Michal – Výbohová Eva: Influence of steaming temperature on chemical characteristics and colour of Alder wood	49
Geffert Anton – Geffertová Jarmila – Dudiak Michal: Comparison of the influence of steaming time and temperature on selected characteristics of birch and alder wood	57
Gochev Zhivko – Vitchev Pavlin: Determination of performance indicators of PCD abrasive wheels for sharpening of tungsten carbide tools	65
Klement Ivan – Uhrín Miroslav – Vilkovská Tatiana – Vilkovský Peter: High-temperature drying of spruce reaction wood	71
Konopka Aleksandra – Baranski Jacek – Orłowski Kazimierz A. – Chuchala Daniel: The effect of drying intensity on the color changes of pine wood (<i>Pinus Sylvestris L.</i>)	84



Novák Igor – Sedliačik Ján – Chodák Ivan – Kleinová Angela – Matyašovský Ján – Jurkovič Peter: Modifikácia vybraných druhov dreva účinkom nízкотеплотnej plazmy	85
Slabejová Gabriela – Šmidriaková Mária: Quality of finish on lightweight plywood	91
Slabejová Gabriela – Šmidriaková Mária: Colour of Thermally modified wood finished with transparent coatings	97
Vilkovská Tatiana – Klement Ivan – Vilkovský Peter – Uhrín Miroslav: The effect of drying temperatures on size of longitudinal contraction different wood species (<i>Fagus sylvatica</i> L. and <i>Picea abies</i> L.)	103
Vukov Georgi – Slavov Valentin – Vitchev Pavlin – Gochev Zhivko: Forced spatial vibrations of a wood shaper, caused by the cutting forces on the worn cutting tool	109



THE EFFECT OF DRYING INTENSITY ON THE COLOR CHANGES OF PINE WOOD (*PINUS SYLVESTRIS* L.)

Aleksandra Konopka – Jacek Baranski – Kazimierz A. Orlowski –
– Daniel Chuchala

Abstract

*The effect of the selection of drying process parameters on the color change of Scots pine wood (*Pinus Sylvestris* L.) is presented. In this work the experimental studies have been performed. The research focused on the influence of drying intensity on the changes of color after drying process. Intensity of drying process was determined on the basis of the average drying gradient. To determine the color of wood before and after drying process the series of experiments have been performed, using color reader device. The wood samples were dried according to three different drying modes, namely: mild, normal and intense. Experiments were conducted in the laboratory dryer. The measurement of wood samples was made using international standards: ISO 11664-2 and ISO 11664-4 of total color change after drying. As a result of the performed statistical tests, there were observed statistically significant color changes of the wood surface for intensive drying mode.*

Key words: *drying process, pine wood, color changes, process intensity*

INTRODUCTION

Wood color is one of the main criteria of assessing its quality and it affects how wood product is perceived by clients. According to ABRAHÃO (2005) homogeneity of wood color is relevant in assessing quality, since, it determines final appearance of wood product. Objective color measurement is performed instrumentally in such a way that it corresponds to visual assessment, using spectrophotometers or color readers devices and is defined in numerical form based on a standardized colorimetric calculation developed by the International Commission on Illumination (CIE - Comission Internationale de l'Eclairage) (KAZIMIERSKA, 2014). In the treatment processes, wood was mechanically processed, dried or subjected to thermal modification, which significantly changes its natural color and chemical composition (GONZALEZ DE CADEMARTORI *et al.* 2013, BARCÍK *et al.* 2015). Significant changes in the structure of wood appear after exceeding 180 °C, while at the temperature of 250 °C the carbonization process begins (KACÍKOVÁ *et al.* 2011).

Instrumental methods for determining colorimetric parameters of color and color difference are subject to ISO standards. Standards contain basic definitions, requirements for colorimetric systems, basics of colorimetric calculus, information for the correct



implementation of instrumental color measurement. In the study, the color change of dried wood was assessed using the three-axis system (Figure 1), measuring: brightness (L^*) and chromaticity coordinates (a^* , b^*), in accordance with ISO 11664-2 and ISO 11664-4. The CIELAB system recommended by CIE consists of two axes with two parameters a^* and b^* , which are at right angle to each other and define the color tone. Third axis is brightness L^* and it is perpendicular to the a^* - b^* plane.

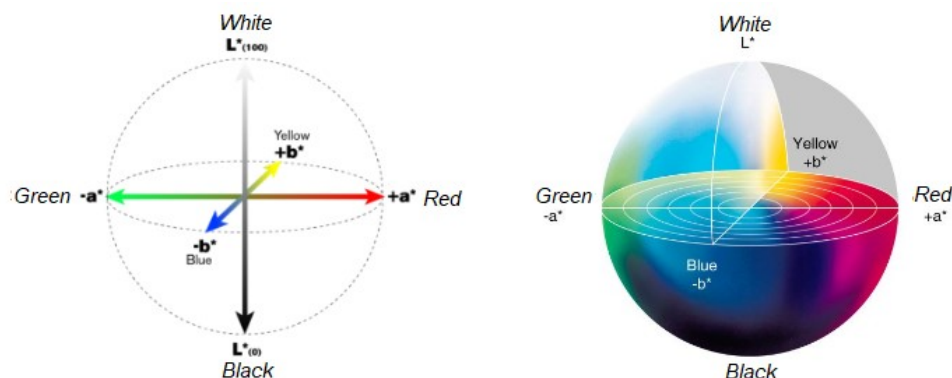

Figure 1. Diagram of a three-axis color change measurement system (SEHLSTED-PERSSON, 2003)

Colorimetric measurement is useful in wood quality control process and in assessing the color of final products of high-temperature drying (KLEMENT *et al.* 2015). The mechanism of color changes is a complicated process and depends on many differentiating and degrading factors (MCCURDY *et al.* 2005, KUDRA *et al.* 2003, McDONALD *et al.* 2010). GLIJER *et al.* 2005 determined the intensity of the drying process based on the drying gradient, which is defined as follows:

$$a = \frac{MC}{EMC} [-] \quad (1)$$

where: MC – wood moisture content [%], EMC – equilibrium moisture content, for the given temperature and relative humidity of drying medium [%].

The aim of the experimental research was to determine the color change of pine wood after drying process using three modes with different levels of the process intensity.

MATERIAL AND METHODS

The drying process of pine wood on laboratory scale was carried out in the HCP108 dryer manufactured by Memmert GmbH + Co.KG from Büchenbach, Germany. Three drying modes were used in the work, the parameters of which are summarized in Table 1.

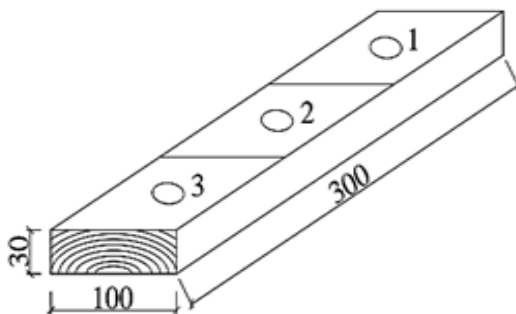

Table 1. Drying medium parameters for modes: mild, normal and intense

Drying mode	MC [%]	t_s [°C]	EMC [%]	Δt [°C]	α [%/%]	RH [%]
mild	> 24 ^(FSP)	50 ±1	11.3	6.3	1.46	70 ±2
	23.9 - 8	60 ±1	9.1	9.0		62 ±2
normal	> 24 ^(FSP)	70 ±1	9.0	9.0	1.77	65 ±2
	23.9 - 8	80 ±1	7.5	11.7		60 ±2
intense	> 40	90 ±1	14.1	2.8	2.56	90 ±2
	39.9 - 24 ^(FSP)	90 ±1	10.0	7.3		75 ±2
	23.9 - 8	120 ±1	4.0	20.0		3 ±2

Legend: FSP – Fiber Saturation Point, MC – moisture content, t_s – temperature of drying medium, EMC – equilibrium moisture content, Δt – psychrometric difference, α – drying gradient, RH – relative humidity

In order to perform a statistical analysis, for each drying mode, 30 pine wood samples (*Pinus sylvestris* L.) with a tangential cross-section were selected. In the Figure 2 was shown schematically the locations of boards to measure the color change of pine wood after drying. Each of 10 boards dried in the process for each intensity mode had three color measurement points before and after drying respectively.

**Figure 2.** The points position of color measurement on samples

The color space of the dried material was determined using Konica Minolta Color Reader type CR10 device. It describes the output coordinates L^* , a^* , b^* by the color change in the color space (Figure 1) using the Equation 2. The color changes were obtained as comparison of measured values of the parameters respectively L^* , a^* , b^* before and after drying (CIVIDINI *et al.* 2007).

$$\Delta E = \sqrt{(L_2^* - L_1^*)^2 + (a_2^* - a_1^*)^2 + (b_2^* - b_1^*)^2} [-] \quad (2)$$

where L_1^* , a_1^* , b_1^* are the values of color spectra before drying process, and L_2^* , a_2^* , b_2^* are the values of color spectra after drying process.

Parameters L^* , a^* , and b^* are coordinates of colorimetric space. The color change criteria are presented below:



- $\Delta E < 0.2$: invisible color change
 $2 > \Delta E > 0.2$: slight change of color
 $3 > \Delta E > 2$: color change visible in high filter
 $6 > \Delta E > 3$: color changes visible with the average quality of the filter
 $12 > \Delta E > 6$: high color change
 $\Delta E > 12$: different color

Bar graphs were prepared and Duncan's test was performed to compare all possible pairs of arithmetic means. If the probability value is greater than the assumed significance level $p > \alpha$, there is no reason to reject the so-called the null hypothesis which states that the observed effect is due to chance. The analysis assumed a significance level of $\alpha = 0.05$ and the STATISTICA 13 (StatSoft, Inc., Tulsa OK Oklahoma, US) program was used to determine the probability.

RESULTS AND DISCUSSION

The measurement data presented in Table 2 contain a summary of the results of the total color change of the tested samples after drying with the use of three drying modes.

Table 2. Color change measurement results for: mild, normal and intense drying processes

Drying mode	Statistic values	L_1^* [-]	a_1^* [-]	b_1^* [-]	L_2^* [-]	a_2^* [-]	b_2^* [-]	ΔE^* [%]
mild	average	70.6	9.1	29.9	74.6	6.7	26.5	6.4
	standard deviation	2.6	1.5	3.3	2.5	1.5	1.7	2.0
normal	average	77.0	6.7	25.6	74.3	8.0	29.2	4.8
	standard deviation	0.5	0.8	1.7	1.3	0.7	1.4	1.1
intense	average	74.2	6.6	24.9	65.2	12.0	33.3	13.9
	standard deviation	1.3	0.5	1.5	3.2	2.3	5.1	5.6

Table 3. Duncan's test for the complete color change of pine wood depending on the drying program used

		Mild	Normal	Intense
		ΔE_1 [-]	ΔE_2 [-]	ΔE_3 [-]
Mild	ΔE_1 [-]	-	0.083619	0.000114
Normal	ΔE_2 [-]	0.083619	-	0.000053
Intense	ΔE_3 [-]	0.000114	0.000053	-



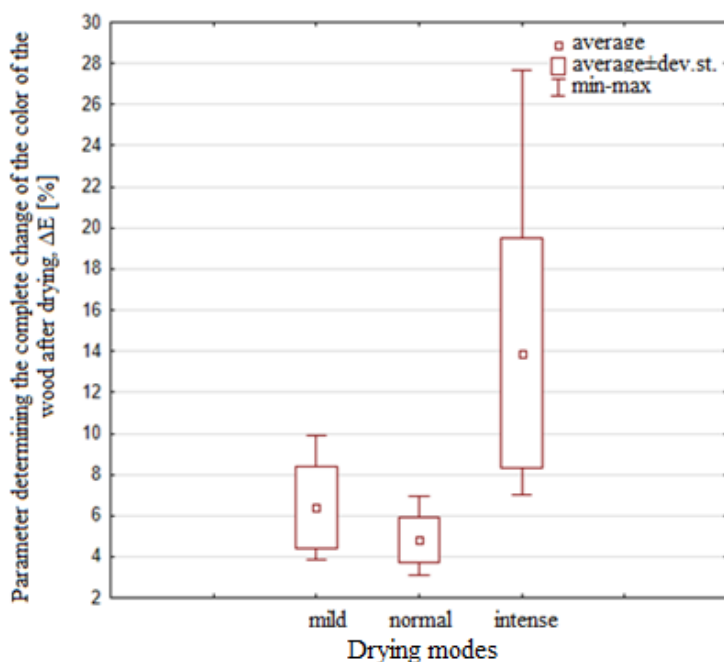

Figure 4. Wood color changes after drying processes with the use of three modes

By analyzing the obtained results (Table 2, Figure 4), it was found that the color change of pine wood after drying, determined by the value of ΔE , increases when the process takes place at temperatures above 100 °C. The change in the color of pine wood turned out to be the smallest for normal drying (the average value of the ΔE parameter was 4.81 %, with a standard deviation of 1.1 %). The greatest color change was achieved during intensive drying (the mean value of the ΔE parameter was 13.9 %, with a standard deviation of 5.6 %).

Duncan's test (Table 3) confirmed a strong statistical difference in the total change in the color of wood after drying between the intensive program and the other drying programs ($p < \alpha$). The drying program at a temperature t_s above 100 °C requires increased relative air humidity RH in the initial stage of the process and its strong reduction when the temperature of the drying agent exceeds 100 °C. This can increase the value of the ΔE parameter, which explains a greater color change. The tendency to stronger discoloration of the wood was also observed by ESTEVES *et al.* (2008), GONZALEZ DE CADEMARTORI *et al.* (2013), UNSAL *et al.* (2003), who underwent thermal modification of eucalyptus and pine wood, as well as the rectification process - MOURA *et al.* (2011).

CONCLUSION

The conducted empirical investigations of pine wood kiln drying revealed that:

- the change of pine wood color depend on the drying mode only for the intensive drying mode, when temperature of the process exceed 100°C;
- according to Duncan's test drying modes mild and normal do not affect the surface color of pine wood.



ACKNOWLEDGEMENTS

This work was supported by the Slovak Research and Development Agency under the contract no. SK-PL-18-0052 and **Polish National Agency for Academic Exchange** NAWA, Poland, Grant no PPN/BIL/2018/100162 are kindly acknowledged.

REFERENCES

- ABRAHÃO, C. P., 2005: Estimation for some properties of the wood of *Eucalyptus urophylla* by spectrometry, Viçosa, Brazil: PhD Thesis, Federal University of Viçosa, pp. 182.
- BARCÍK, Š., GAŠPARÍK, M., RAZUMOV, E. Y., 2015: Effect of temperature on the color changes of wood during thermal modification. *Cellulose Chemistry and Technology*. 49 (9-10), pp. 789-798.
- CIVIDINI, R., TRAVAN, L., ALLEGRETTI, O., 2007: White beech: a tricky problem in the drying process. Québec City, Canada, 24–26 September.
- ESTEVES, B., VELEZ MARQUES, A., DOMINGOS, I., PEREIRA, H., 2008: Heat induced colour changes of pine (*Pinus pinaster*) and eucalyptus (*Eucalyptus globulus*) wood. *Wood Science and Technology*. 42 (5), pp. 369-384.
- ISO 11664-2: 2007 Colorimetry - Part 2: CIE standard illuminants. *International Organization for Standardization*, Geneva, Switzerland.
- ISO 11664-4: 2008 Colorimetry - Part 4: CIE 1976 L*a*b* Colour space. *International Organization for Standardization*, Geneva, Switzerland.
- GLIJER, L., 2005: Suszenie i parowanie drewna, Warszawa: Wieś Jutra.
- GONZALEZ DE CADEMARTORI, P. H., SCHNEID, E., GATTO, D. A., STANGERLIN, D. M., BELTRAME, R., 2013: Thermal modification of *Eucalyptus grandis* wood: Variation of colorimetric parameters. *Maderas. Ciencia y tecnología*. 15 (1), pp. 57-64.
- KACÍKOVÁ, D., KACÍK F., 2011: Chemical and Mechanical Changes during Thermal Treatment of Wood. *Technical University in Zvolen (Slovakia)*, pp. 71.
- KAZIMIERSKA, M., 2014: Obiektywna ocena barwy wyrobów użytkowych. *Technologia i Jakość Wyrobów*. 59, pp. 44-47.
- KLEMENT, I., HURÁKOVÁ, T., 2015: High temperature drying of beech wood with content of red heartwood. Selected Processes at the Wood Processing, Hokoce (Slovakia).
- KUDRA, V. S., VITTER, R. M., GAIDA, Y. I., 2003: Effect of false heart on the quality of beech wood. *Lesnoe Khozaistvo*. 5, pp. 23-24.
- MCCURDY, M. C., PANG, S., KEYEY, R. B., 2005: Measurement of colour development in *Pinus radiata* sapwood boards during drying at various schedules. *Maderas. Ciencia y Tecnología*. 7 (2), pp. 79-85.
- MCDONALD, A. G., FERNANDEZ, M., KREBER, B., LAYTNER, F., 2010: The chemical nature of kiln brown stain in *Radiata* pine. *Holzforschung*. 54, pp. 12-22.
- MOURA, L. F., BRITO, J. O., 2011: Effect of thermal rectification on colorimetric properties of *Eucalyptus grandis* and *Pinus caribaea* var. *hondurensis* woods. *Scientia Forestalis*. 39 (89), pp. 69-76.
- SEHLSTED-PERSSON, M., 2003: Color responses to heat treatment of extractives and sap from pine and spruce. The 8th International IUFRO wood drying conference pp. 461, ISBN 973-635-198.
- UNSAI, O., KORKUT, S., ATIK, C., 2003: The effect of heat treatments on some properties and colour in *Eucalyptus camaldulensis* Dehn. Wood. *Maderas. Ciencia y Tecnología*. 5 (2), pp. 145-152.

