

# The Use of Tamping Machine for Diagnosing the Longitudinal Forces in Rails of CWR Track

Wladyslaw Koc<sup>1</sup>, Andrzej Wilk<sup>2</sup>, Sławomir Grulkowski<sup>1</sup> and Piotr Chrostowski<sup>1</sup>

*1 Department of Rail Transportation, Faculty of Civil and Environmental Engineering, Gdansk University of Technology, Gdansk PL 80-233, Poland*

*2 Faculty of Electrical and Control Engineering, Gdansk University of Technology, Gdansk PL 80-233, Poland*

**Abstract:** In the novel approach to the diagnostic tests of continuous welded rail (CWR) track by the use of the tamping machine, the fundamental statement related to the recording of the curvature with a definite value of the lateral displacement being subjected to verification, can provide a basis for the determination of the longitudinal axial force in the rail. An attempt has also been made to define an alternative factor which by means of the measured signals, could be used for the determination of the axial forces in the rail sections. A power engineering approach has been adopted to this concept. Within the framework of the experimental investigations, measurements were carried out in the track test section. The investigations were based on stretching the rail sections by stretchers and on lateral displacements of the track by the tamping machine. The operation of the measuring apparatus was also tested in the experimental railway track section while carrying out the geometrical adjustments by the tamping machine. As a result of next series of the investigation carried out in 2006-2007, the authors worked out a procedure of estimating the longitudinal forces in rails of CWR track.

**Key words:** CWR track, longitudinal forces, lateral displacements, tamping machine, measuring apparatus.

## 1. Introduction

For many years research have been conducted in different countries aimed at finding a method for the determination of longitudinal forces in continuous welded rails. The stability of the continuous welded rail track (CWR track) depends mostly of the state of the longitudinal forces in rails. Under the influence of various factors, in the rails of the CWR track there occur localizations of normal stress concentrations. For this reason very often it is not clear what value of the force occurs in given location of the track. In extreme cases the longitudinal force can lead to the track's buckling, especially in time of high temperatures as well as to rails' cracking in wintertime.

The range of the researches is astonishing, but their effects are still unsatisfactory, because a method of

immediate measurement of the longitudinal forces appropriate for maintenance service conditions has not been developed.

An interesting proposal to solve this problem is offered by the technique of forced lateral displacements, which is based on lifting a rail section detached from the sleepers to a certain height, and registering the vertical force needed for this operation. This method was used in the USA [1] and Great Britain [2] for the determination of the longitudinal forces in CWR track. However, it only reached the stage of its implementation and did not gain a wide application. This fact was not only due to the necessary disassembly of the elements fixing the rails to the sleepers along significantly great lengths but primarily because of substantial methodological limitations. As the experimental investigations carried out at the Gdansk University of Technology [3] have proved, the application of rail displacement in the horizontal direction is more advantageous in the assessment of longitudinal forces in the rail track.

---

**Corresponding author:** Wladyslaw Koc, PhD, professor, research fields: experimental research on cwr track, modelling of track geometrical systems, application of satellite measurements in railroads. E-mail: kocwl@pg.gda.pl.

The idea itself of the forced lateral displacements is undoubtedly correct, but the experimental work conducted at the Gdansk University of Technology were oriented around the excitations of horizontal displacements of the whole rail track panel by means of the tamping machine [4]. The investigation program being realized at present, is the result of field experiments by the application of the tamping machine, and is carried out at the railway track's testing section in use. The measurements were based on stretching both the rail track sections (in the range of  $0 \div 500$  kN) and horizontal displacement of the rail track panel. Using an original measuring apparatus [5] it was possible to register the signals of the lateral force, the axial force in rail, and the horizontal displacement. The most significant information was obtained from the signal analysis of strain in rail being bent.

During the tests, axial strains in the rail were registered by using a linear induction sensor. This made it possible to determine the axial force introduced by rail stretcher prior to the lateral displacement of the track. In course of stretching the rail-track the readouts from the sensor provided data characterizing the curved axis of the deformed rail, thereby determining in an assumed way, its horizontal curvature. The obtained numerical value  $\Delta S$  was dependent on the construction of the sensor. It was expressed by using units of force,

although in fact the sensor indicated force in rail only when the lateral displacement was equal to zero.

As stated, value  $\Delta S$  indicates an evident dependence on the axial force  $P$  occurring in rail before the rail track displacement operation. Value  $\Delta S$  decreases together with the rise of force  $P$ , which conforms to smaller curvature of the rail being bent. Hence, it is possible to conclude that the curvature recording with a specified lateral displacement value  $y$  can form a basis for the determination of the axial force in rail. Consequently, it has been used in further research [6].

## 2. Methodological Assumptions

There has been adopted a method of estimating the curvature value by an appropriate factor, taking advantage of the lateral displacement measurements at three points; in the length of 2.4 m in the vicinity of lifting–shifting unit, as shown below in Fig. 1.

The way of calculating the curvature index is displayed in Fig. 2. The measurement of the horizontal displacements  $y_1$ ,  $y_2$  and  $y_3$  is carried out by sensors installed on the frame of the rail track tamping machine. The adopted curvature index  $k_2$  is determined by the value of the horizontal arrow at point 2 for the chord joining points 1 and 3. The value of factor  $k_2$  depends on angle  $\alpha$  between the tangents to the bending curve at both the extreme measuring points. This indicates a compatibility

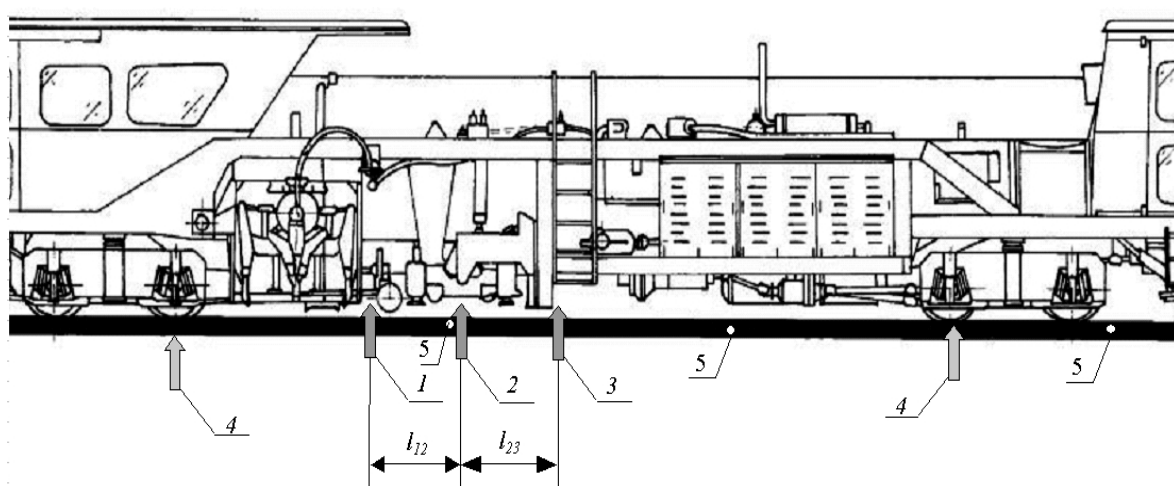
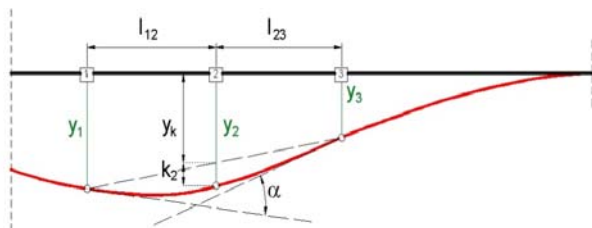

Fig. 1 Simplified schema of the tamping machine with marked measurement points: 1, 2, 3—the rail displacement measurement points, 4—internal axles of the bogies, 5—the places of strain gauges;  $l_{12}$ ,  $l_{23}$ —distance between displacement measurement points.



**Fig. 2** The schema of the idea of the curvature index  $k_2$  estimation: 1, 2, 3—displacement measurement points;  $y_1$ ,  $y_2$ ,  $y_3$ —the value of transverse displacement in the measurement points 1, 2, 3;  $\alpha$ —the angle between tangents of deformed track shape.

with the curvature definition, of course, involving some approximation.

As it follows from Fig. 2 the curvature factor  $k_2$  constitutes the difference of ordinate  $y_2$  and value  $y_k$  determined from the following relation (for  $y_1 > y_3$ ):

$$y_k = y_1 - (y_1 - y_3) \frac{l_{12}}{l_{12} + l_{23}} \quad (1)$$

### 3. Construction of the Measuring Apparatus

#### 3.1 Adopted Concept of the Measurement

At first the adopted measuring concept assumed a technique similar to the one incorporated in the tamping machine. In this technique the mechanical system transfers the displacements of the rail head to two electric converters. One of them transforms the horizontal displacements, and the other the vertical ones. The mechanical system of the measuring carriage of the tamping machine and its suspension constitute a fairly robust and complex construction.

The tests carried out in connection with the project [3] have resulted in setting out some preliminary requirements relating to the measuring capacity of the new apparatus installed in the rail track tamping machine. Following some earlier technique the method of determining the rail curvature is based on the displacement measurement of the rail track section taken at three points arranged along the length of the measuring base of the tamping machine. The range of the displacement of the points in course of the operational use of the machine is different. The largest displacement in the horizontal direction takes place

near the lifting-shifting system. In this place the displacement  $y_{\max}$  of the rail can attain a magnitude of a dozen centimeters. This means that the measuring apparatus at the point of the biggest displacements must have an amplitude range of  $2 \cdot y_{\max}$  and a surplus resulting from various (occasionally occurring) excessive displacements of the whole rail track panel, which gives a value amounting to approx.  $\pm 0.15$  m, i.e., a total of 0.30 m. The largest displacements in the vertical direction occur also in the area of the lifting-shifting system and can reach up to more than ten centimeters. During the operation of the tamping machine both the horizontal and vertical components of the rail displacement can take place.

The minimum displacement amplitudes in rail occur in the area located nearest to the axis of the tamping machine traveling carriage behind the measuring point. The values of these amplitudes can attain a dozen of millimeters, both in the horizontal and the vertical direction. Thus they are much smaller than in the vicinity of the lifting-shifting system.

As a consequence, the range of the measured value at particular points of the rail during the curvature testing are various.

However, the accuracy of the measurement should be the same or in a very close approximation to the real value. This causes some complications in regard to the measuring apparatus since it is necessary to create a very precise measuring system. The system should measure accurately enough not only the large displacements but also the small ones. In case of incapability of satisfying the required accuracy by one measuring system, it might be useful to apply two systems of a different construction or principle of operation, suitable for the amplitude range of the real displacements, fulfilling satisfactorily the measurement requirements. The results obtained from the analysis of the railway track mathematical model indicate that the measurement error should not exceed  $\pm 1.5\%$  for each nominal value at particular points. To obtain such accuracy by the currently in use techniques

and measuring instruments should not pose greater problems, which is valid particularly for the static measurements. In the case of dynamic phenomena when the rail displaces and bends in space and the deformation is accompanied by the vibrations transmitted by the tamping machine, the situation becomes more complicated, especially when the rail surface is covered in mud or dust.

Taking into consideration the experiments which have been carried out by the authors, including the construction of several prototypes for the measurement of the rail displacement (that have not proved under conditions of simultaneous operation with the tamping machine systems), a final solution has been proposed which does not require any constructional changes to be made in the machine, and enables the apparatus to be portable.

The idea of such a solution is illustrated in Fig. 3. Along the rail head (1), a part of the apparatus slides in a form similar to a rectangular prism. The sliding plate (3) is equipped with an induction sensor made of ellipsoidal magnetic coil enclosed in the holder (2). The aim of the sensor is to measure the transverse displacements of the rail head. The sliding plate is firmly fixed with a metal beam (5) by means of a nonmetallic extension arm (4). The frame is fastened transversely to the shaft (6) which can turn freely around its own axis. The shaft rests on bearings (7) installed in the grip fixed to the tamping machine frame. The grip is also equipped with another induction sensing element (8) to measure the angular displacement of the apparatus beam. The sliding plate is made of plastic material PE1000 (sort of polyethylene) characterized by a high wear resistance and low friction factor.

The principle of operation of the apparatus is as follows, during the transverse displacement of the rail, the distance (the equivalent air gap for magnetic flux) between the rail head and the magnetic coil is changing. The variation of the gap occurs as a result of the inclination of the plane of winding in relation to the sliding plane of the apparatus, which causes an

inductance change of the magnetic coil. The coil is an element of the electrical circuit composed of inductors, capacitors and resistors which operate in electrical resonance. Electrical simplified scheme of this circuit is shown in Fig. 4. Due to the induction changes the impedance of the resonant circuit rises or declines depending on the decrease or increase of the air-gap. Consequently the impedance value of the resonant circuit

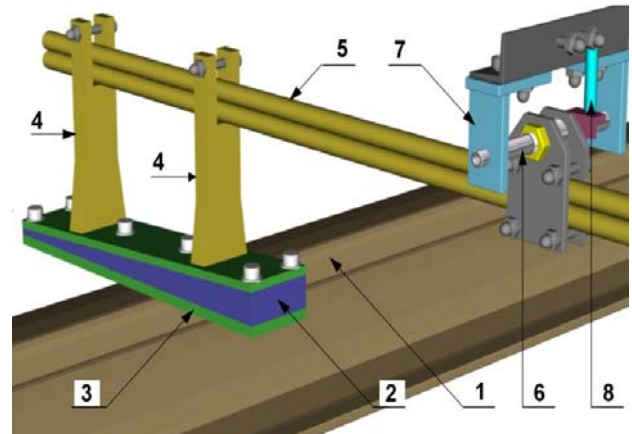

Fig. 3 3D model of the mechanical system of the measuring apparatus for displacement of rail: 1–rail head, 2–ellipsoidal magnetic coil holder of the apparatus, 3–special sliding plate, 4–extension arm connecting the sliding element with the beam, 5–rotational beam, 6–shaft, 7–clamping fixture of the rotational part of the apparatus, 8–magnetic sensor to measure the angular displacement.

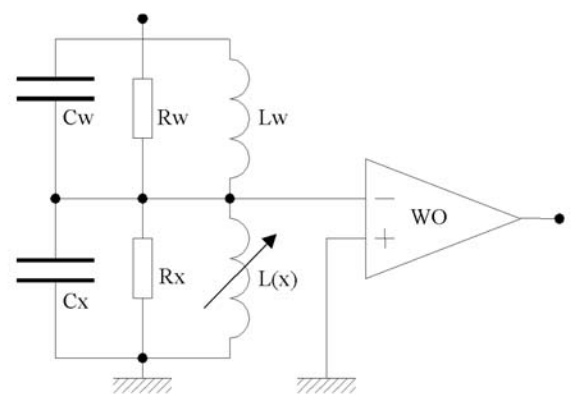

Fig. 4 Electrical scheme of inductance-capacitance-resistance bridge in the sliding element for rail displacement measurement:  $C_w$ ,  $R_w$ ,  $L_w$ –capacitance, resistance, and induction reference standards, respectively,  $C_x$ ,  $R(x)$ ,  $L(x)$ – capacitance, resistance, and induction of the equivalent resonant circuit of the elliptical magnetic coil, respectively, OA–operational amplifier. Parameters  $L(x)$  and  $R(x)$  are functions of the rail head displacements.

exerts an effect on the voltage drop of the circuit. The voltage drop is subsequently transformed to an appropriate form and carried to the input of the measuring card.

The sensing element for the frame angular displacement is a classic sensor for eddy currents. The measurement of the angular displacement is carried out by attaching a cam mechanism to the axis of the rotational shaft. A turn of the shaft causes a change in distance of the cam measuring surface area from the front end of the sensor. This results in voltage variation, at the outlet of the eddy current sensor, which is subjected to further treatment appropriate for the input measuring card.

### 3.2 Characteristic of the Measuring Apparatus

The main constructional element of the apparatus is the element sliding along the rail head, which is made of special plastic material. The sliding element is joined to a beam able to make a turn. When the rail is moved by the lifting-shifting system, the sliding element lies on the rail head without losing contact with the rail. An advantageous feature of such a solution is the accurate measurement of the distance vector  $\mathbf{r}$  between a characteristic point of the tamping machine frame and the upper surface of the rail head. This relation can be described by the equation

$$\mathbf{r} = R(y, z)e^{j\alpha(y, z)} \quad (2)$$

where:  $R$  is the distance between the rail head and axis of beam revolution,  $\alpha$  is the angle between the vector  $\mathbf{r}$  and  $y$  axis.  $R(y, z)$  and  $\alpha(y, z)$  are functions of  $y$  and  $z$  components as show in Fig. 5.

The value of radius  $R$  is measured by an induction sensor located in the sliding element and depends mainly on  $y$  component which describes the lateral movement of the track, relative to the tamping machine's longitudinal chassis (see Fig. 5). However the  $R$  value is also slightly dependent on the angular displacement  $\alpha$  of the beam. This is due to the fact that the effective gap between the magnetic coil in the sliding element and the rail head, changes as the sliding element contacts the rail head near its edge. The angle of the beam rotation is measured by a magnetic sensor located near the axis of the beam rotation. The value of angle is dependent mainly on vertical displacement of the rail head. For the purpose of obtaining accurate measurements of the rail head position in space it is necessary to measure simultaneously two signals. They are, the angle  $\alpha(y, z)$  and the vector modulus  $R(y, z)$  of the rail head position.

A block diagram of the whole electric system of the apparatus is illustrated in Fig. 6. The tamping machine is equipped at least with three apparatuses for the measurements of the rail displacements. Therefore it is

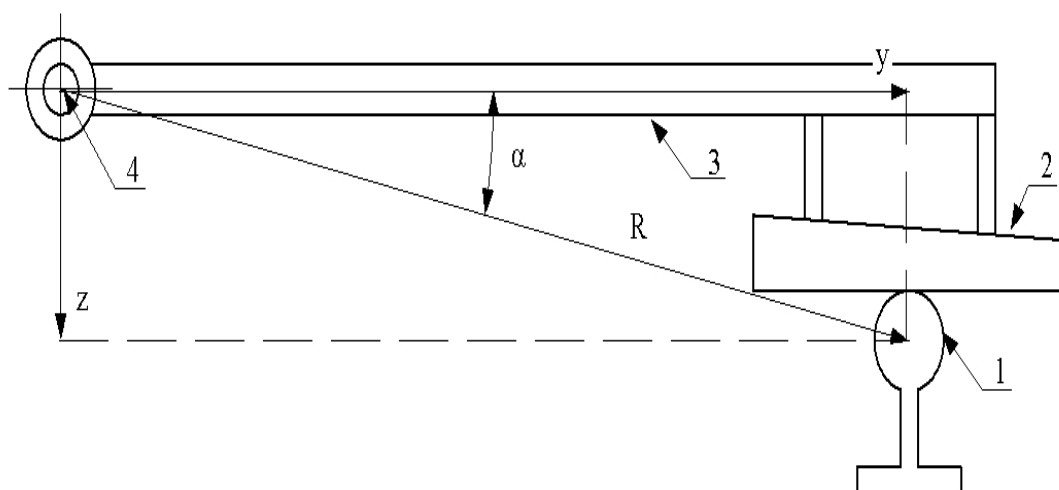
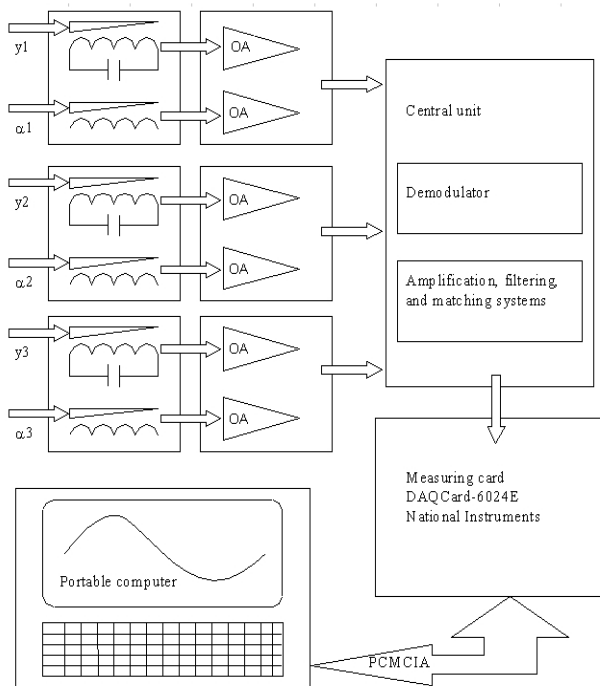

Fig. 5 Simplified drawing of the measuring apparatus showing relations between  $y$ ,  $z$ ,  $R$ ,  $\alpha$  geometrical components, where: 1–rail, 2–sliding element, 3–beam, 4–axis of rotation.



**Fig. 6** Block diagram of the electronic circuit of the apparatus for measuring the rail track curvature:  $y_1$ ,  $y_2$ ,  $y_3$ —horizontal transverse displacements of rail transformed by the sensors in feet 1, 2 and 3;  $\alpha_1$ ,  $\alpha_2$ ,  $\alpha_3$ —angles of rotation of the beams to which feet 1, 2 and 3 are fixed.

recommended that six signals should be measured at the same time. Converters of the mechanical quantities to electrical values are connected by screened cables with the central unit located in the operator's cabin. The output signals from the converters are electrical voltages modulated by their amplitudes. The central unit is responsible for the demodulation process, the filtration and the amplification of signal to an appropriate level. The signal processed in such a way is transferred to the input of multi-functional DAQCard-6024E-type measuring card, situated in a portable computer by using PCMCIA connection.

Each of the three instruments constituting the apparatus has a particular feature, not shared with others, of the electric voltage in function of the rail horizontal displacement  $U(y)$  and the voltage in function of the sliding element's angular displacement  $U(\alpha)$ . Figs. 7 and 8 give the characteristics of  $U(y)$  and  $U(\alpha)$  for the one of the apparatus. The software elaborated for the project enables a storage of the data

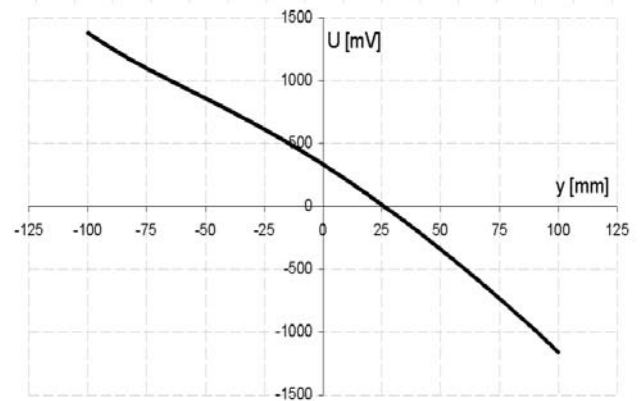

**Fig. 7** Output voltage  $U$  of the sensor for radius  $R$  measurement versus  $y$  component of the rail head position.

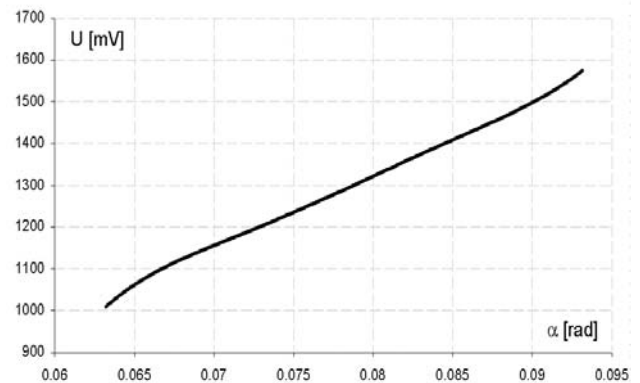

**Fig. 8** Output voltage  $U$  of the sensor for angle measurement versus angle  $\alpha$  of beam rotation.

in the computer's mass memory practically in real time. The number of the registered samples depends only on the capacity of the computer's mass memory.

### 3.3 Operation of the Apparatus during the Experiment

The apparatus is of portable type. It can be attached to the track machine directly prior to the commencement of the geometrical track lining. The installation of the apparatus takes about 30 minutes of two labourers' working time. The apparatus does not use any functional systems of the track machine during its operation. The apparatus is fixed on the frame of the machine, which is used as the reference system.

Figs. 9 and 10 show the apparatus installed on the tamping machine near the lifting shifting system and in the center of measurement's reference length respectively.

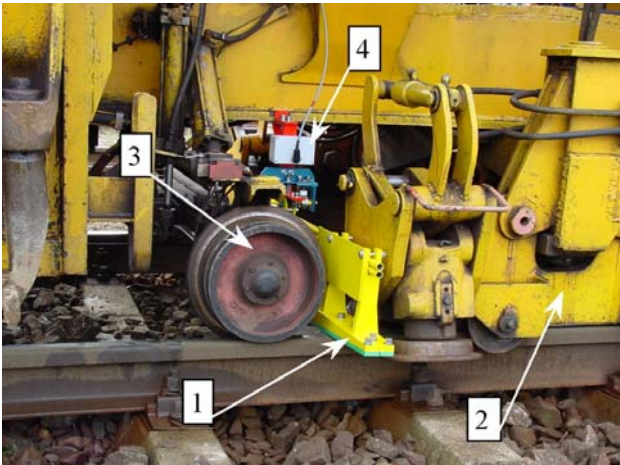

**Fig. 9** View of the apparatus installed near the lifting-shifting system of the tamping machine: 1–sliding element with, 2–lifting and shifting system, 3–wheel of measurement bogie, 4–enclosure of electronic system of apparatus.



**Fig. 10** View of the apparatus installed in the central region.

The one of the used apparatus is installed between the measurement bogie and the lifting-shifting system. While carrying out the measurements, it was remarked that (sometimes) the section was too short for the sensor in sliding element of the apparatus to function correctly. The relatively great surface area, the mobile parts of the tamping machines and the lifting-shifting system caused significant disturbances to the signal being processed. It was not possible to eliminate, or to filter these disturbances. This fact led to the conclusion that the construction of the sensor should be modified or the distance between the measurement bogie and the lifting-shifting system of the machine should be

elongated. However, it seems that technically it is easier to replace the measuring sensor by a sensing element operating on a different principle.

The remaining sensors did not cause any problems. The only difficulty was to find suitable sliding material for the bottom surface of each sliding element. There were not found any traces of too extensive wear of the material to necessitate its replacement. The authors adapted the sliding element (if necessary) for replacement. For the reason the element is mounted by using special nonmetallic screws (and can be disconnected).

## 4. Experimental Investigations

### 4.1 Scaling of the Measuring Sensors

The described apparatus for the measurement of horizontal transverse displacements, and the vertical angle, incorporates eddy current sensors. The output signal in this type of sensors is voltage (electric signal). For this reason it was necessary to carry out the scaling of the sensors, that is, the determination of functions enabling them to convert the electrical signals into their adequate displacement values. The scaling was carried out in a mechanical workshop. In order to execute the scaling operation in a laboratory, the authors used the milling table, which allowed to perform the displacements in both (horizontal and vertical) directions with needed accuracy. At first the measuring instrument was fixed to the table so that the bottom plane of the sensor for the transverse displacement might be set in the horizontal position, centrally in relation to the rail head. For such a position it has been assumed that the current signal of the angular displacement sensor corresponds to  $0^\circ$  angle and is an apparent reference level. The instrument was next displaced in the transverse (horizontal) direction simulating in this way the railway track's shifting process, and in the vertical direction to simulate the track's lifting operation. The recording of the signal under conditions of during displacements' variations was carried out every 10 mm for transverse

displacements in the range of  $-100$  to  $+100$  mm (with respect to the centre of the sensor), whereas every 5 mm for vertical displacements in the range of  $-50$  to  $+50$  mm (in relation to the apparent reference level). Those actions let the authors prepare the sensors' characteristics for the purpose of scaling the voltage signals into millimeters and degrees values. In the recording of the electric signals, use was made of a set of computers provided with specialist software.

Characteristics of horizontal and angular displacements, in functions corresponding to their electric signals  $R(Uy)$ ,  $\alpha(U\alpha)$ , made it possible to determine the analytical relations linking the measured voltage values with adequate metric quantities referring to the transverse and the vertical displacements.

#### 4.2 Measurements in the Test Track Section

The experimental test track section was situated at rail track in operational use, being temporarily (for more than ten hours) disconnected from regular exploitation. In order to apply the axial force into rails, the tested track section was isolated by cutting of the rails. Obtained gap in rails let for installation the rail

tensors on the both ends of 25 m long track panel. The key issue of the experiment was controlling the tensile force, applied by the use of rail tensors. The force's value has been read from the tensors' manometers. The range of applied axial forces was  $0 \div 500$  kN with the 50 kN step. When the needed force was obtained (for each 50 kN step), the tamping machine started performing the transverse displacements of the track grate. The maximum value of transverse dislocation was about 50 mm.

Fig. 11 gives examples of the measuring results obtained in the experiments using tensile axial force of  $P = 500$  kN.

The major problem noticed in the investigation is connected with the sensor No.1 for  $R$  measurement. The sensor was installed in the vicinity of the lifting-shifting system where, as it turned out, the signal disturbances relating to the transverse displacements were so great that it was not possible to eliminate or filter them. The signal is essential since it provides information from the region of the largest displacements. It appeared that in spite of possessing five signals, the capabilities of a detailed analysis are

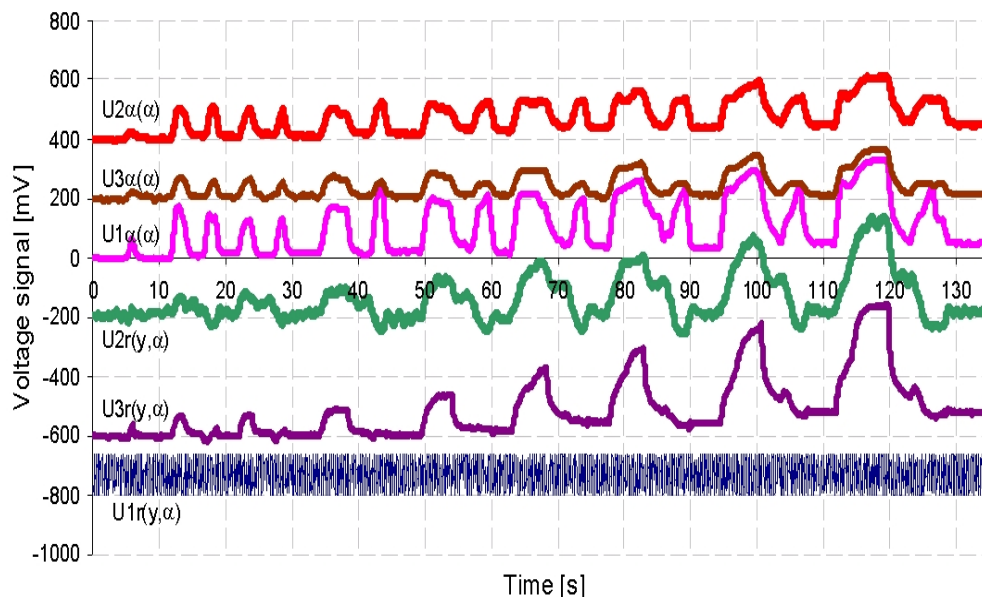

Fig. 11 Time signals from all sensors using axial force.  $P = 500$  kN:  $U1r(y,\alpha)$ —voltage of the sensor No.1 for  $R$  measurement,  $U1\alpha(\alpha)$ —voltage of the sensor No.1 for  $\alpha$  measurement,  $U2r(y,\alpha)$ —voltage of the sensor No.2 for  $R$  measurement,  $U2\alpha(\alpha)$ —voltage of the sensor No.2 for  $\alpha$  measurement,  $U3r(y,\alpha)$ —voltage of the sensor No.3 for  $R$  measurement,  $U3\alpha(\alpha)$ —voltage of the sensor No.3 for  $\alpha$  measurement.



very limited. Two signals of transverse shifting are insufficient to determine the track horizontal curvature. Hence it is implied that the construction of the sensor under evaluation should be changed. In this respect appropriate action has already been taken.

Although the basic aim in the experiments, i.e., the determination of the relation between the horizontal curvature and the longitudinal axial force has not been achieved, extensive research material has been acquired, which can be utilized elsewhere, e.g., in the analysis of the track lifting-shifting operation carried out by the rail track tamping machine. But even for the constrains indicated it is possible to observe some phenomena which prove that the adopted investigation direction is right.

The experiments showed that the curvature index depends of the longitudinal force level in the rails. The values of displacements  $y_3$  recorded by the extremely localized sensors (see Fig. 2) were larger when the value of longitudinal force in rails was larger. The fact indicates decrease of curvature index when the axial force increases. For example, for force  $P = 0$  the maximum signal's value of the sensor No. 3 located few meters from the sensor of maximum displacement (see Fig. 2) equals  $y_3 \cong 350$  mV. For the same value of track's maximum displacement ( $y_2$ ) and for the greater values of longitudinal force in rails:  $P = 300$  kN– $y_3$  equals approx. 400 mV, and for  $P = 500$  kN– $y_3$  equals approx. 450 mV. Because all the values of displacement  $y_3$  were obtained for the same value of track's maximum displacement  $y_2$ , it is clear, that the value of the curvature index decreases with the increment of the longitudinal force in the rails. This effect verifies indirectly the correctness of the adopted measurement methodology.

#### 4.3 Measurements of the Railway Track under Operation

The tests carried out during the repair works of the railway track provided an essential verification of the measuring equipment and the measuring concept. The

tests included three measurement cycles performed in different areas.

The first measurement cycle took place at the railway station of Gralewo (Warsaw – Gdansk railway line) during the course of repair works going on in track no. 2. The work was aimed at cleaning the fouled ballast-bed in the station's track. The tamping machine should lift the track and lay it at a distance of approx. 1250 mm from the edge of the platform in order to enable the cleaning machine to perform its work. However, due to a damage to the cleaning machine it was not possible to perform and finish the task. The only positive operation carried out was the lifting of a track section of approx. 50 m length. The operation was accompanied by observation of the installed measuring instruments and the recording of signals. The measurement was treated as a test of the apparatus carried by the tamping machine in operation. During the operation of the equipment no faulty functioning of the measuring apparatus was noticed, except of that of the middle positioned shifting sensor (No. 2).

The next measurement cycle was also performed in the same railway line Warsaw – Gdansk at track no. 2 near the village Smolniki. The experiments were carried out at temperature of approx. 5 °C. The range of works also included the cleaning of the fouled ballast-bed along a track section of a length of approx. 200 m. During several passes of the tamping machine removing the track from the platform edge at the station of Smolniki, a total of nine measuring series was performed. The first pass (the first measuring series) consisted of a simple track lifting operation without shifting. Further work of the tamping machine included the displacement of the track away from the platform. It is worth mentioning that, on the day preceding the tests, while carrying out similar works, the rail cracked under the tamping machine along the same length of the railway line. Fig. 12 shows the time signals registered by all the sensors for a selected series of measurements.

Subsequent measuring series were realized while



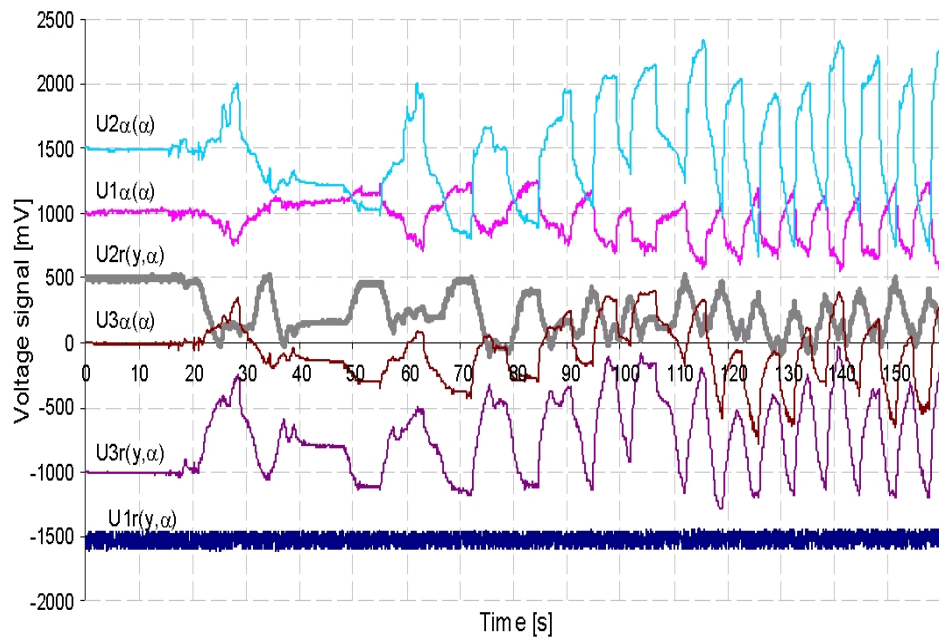

**Fig. 12** Time signals from all sensors for a selected series of measurements (region of Smolniki station):  $U1r(y,\alpha)$ –voltage of the sensor No.1 for R measurement,  $U1\alpha(\alpha)$ –voltage of the sensor No.1 for  $\alpha$  measurement,  $U2r(y,\alpha)$ –voltage of the sensor No.2 for R measurement,  $U2\alpha(\alpha)$ –voltage of the sensor No.2 for  $\alpha$  measurement,  $U3r(y,\alpha)$ –voltage of the sensor No.3 for R measurement,  $U3\alpha(\alpha)$ –voltage of the sensor No.3 for  $\alpha$  measurement.

carrying out the repair works in the region of the village of Konopki (Warsaw–Gdansk line) in track no. 2. The works included a similar range of works as before. Similar operations were also performed by the tamping machine. During the works appropriate signals were recorded in course of shifting and lifting the rail track up to desired height as soon as the cleaning job had been completed by the cleaning machine. The length of the track section under repair was approx. 250 m, and the temperature at which the works were conducted was  $-1^{\circ}\text{C}$ . Time characteristics for six series of measurements were recorded.

From the field experiments it was possible to acquire an abundant investigation material, which cannot be immediately utilized due to lack of data from the shifting sensor situated in the middle apparatus (No. 2). The major investigation result was to prove the correctness of the functioning of the remaining sensors. This was particularly significant with regard to the shifting sensing elements which operate on an original principle and are adapted for cooperation with the traveling tamping machine. Owing to them it was

possible to register the manner of the operator's work.

## 5. The New Series of Research

### 5.1 Assumptions

Further tests should be conducted on smaller samples, as part of university's research. In 2006-2007 it was succeeded in performing very interesting experiments, with the serious support of PPMT (Pomeranian Mechanical Track Company Ltd in Gdansk) in Gdansk, in 2006 and 2007, and the results appeared to be very interesting.

Just to prove the above hypothesis, the experiments in the test track section have been performed. The main essence of the investigation was the same as previously but the displacement sensors for measuring transverse displacements were changed by the inductive sensors of a different type. Additionally, the research program expanded with the analysis of the measurement with the piston rods of horizontal hydraulic actuators under stress. This element was added in order to determine the lateral resistance. In order to prove the above hypothesis,

several experiments have been performed in the test track section. The concept of the investigation has not been changed, except for using the inductive sensors of different type to measure the transverse displacement, instead of using the initial apparatus.

It has been decided that during the measurements on track, the grate displacements should be related to the measurement base connected with the tamping machine. The authors assumed that during the displacement process, the main frame of tamping machine is motionless, so it turns out to be an excellent base of reference in the measurement of track displacement, thus cylindrical inductive sensors with moving cores were used. It was necessary to design proper supporting frames which allowed a correct setting of the sensors relatively to the rail, in order to achieve proper performance. The sensor's core was supplied with a proper ball-shape nut (for obtaining the point contact between the rail surface and the core) and with a spring (for obtaining the permanent contact between rail and core). The whole measurement set up is shown in Fig. 13. The signal from the sensor was processed by the adequate electronic unit. For the above reasons and proper voltage supply (230 V alternating current AC—not available in the tamping machines in use) this apparatus could be utilized only in the case of experiments in the test track section.

In the experiment there was an additional element



**Fig. 13** CL70-200 inductive sensor mounted by the support frame close to the slewing position.

controlling the longitudinal force in rail, described below. Along the investigated section there were placed strain gauges in three positions. The sensors were situated on both sides of rail web on the height of its neutral axis. Such placement of the strain gauges enables the measurement of the longitudinal force along the tested track section, taking into account the rail bending (during transverse displacement). The controlled longitudinal force was applied by the use of the rail tensors situated on each side of the rails.

Before the measurement process, the tested track section was prepared so, as four rail tensors to be placed. Moreover, the fastenings were loosened, in order to achieve a regular distribution of the axial force in rails. Both rails were tensioned in order to obtain the presupposed value of axial force. After that, the track has been displaced transversely and the basic measurement procedure started. The displacement was performed in the  $1\pm 100$  mm range. The series of the measurements were performed with a fluctuating value of the longitudinal force:  $P = 0$  kN,  $P = 100$  kN,  $P = 200$  kN and  $P = 300$  kN.

### 5.2 The Results of Investigation of Longitudinal Force

The axial force in the rail was controlled by the use of the strain gauges. Three sets of sensors were installed along the test track section. Actual measurement allowed the authors to assess the distribution of the force in the rails. The measuring points were arranged along the rail in such way that one of them was placed between the tamping machine's ride axles, whereas the remaining two—on both sides of the machine near the rail tensors.

The longitudinal force applied by the rail tensors as time functions are shown in Fig. 14. In this figure the distribution of longitudinal force in the tested rail section is also shown. It is observed that normal stress distribution changes along the rail. The shape of the force signal measured in three different points is similar.

As far as the displacement measurement is concerned, the measured time signals from all of the inductive

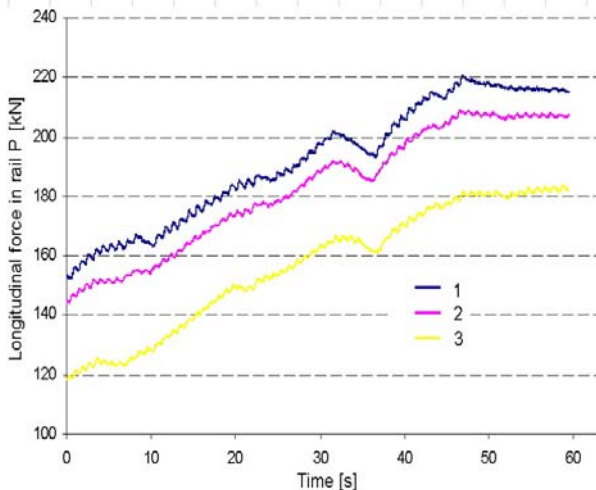

Fig. 14 Exemplary time signal as an illustration of longitudinal force increment during the track dislocating: 1–signal of measurement point 1, 2–signal of measurement point 2, 3–signal of measurement point 3.

sensors make it possible to control the character of the process of track displacement as a result of operator's work. Measured time signals from inductive sensors allowed to describe a track displacements in measurement points 1, 2 and 3 located on the length of the tamping machine, whereas index  $k_2$  describes the curvature in the middle measurement point. Fig. 15 shows the time signals representing two cycles of lateral displacement in the test track section.

As illustrated above, all of the measurement series consist of the same stages:

- (1) stage I—the operator makes transverse track displacement, till obtaining the given maximum value;
- (2) stage II—the operator holds the track in the maximum displacement's position;
- (3) stage III—the operator reduces the force to 0-value in hydraulic actuators and the track freely returns towards the initial position;
- (4) stage IV—The track usually does not reach the initial position due to occurring friction forces (contact between sleepers and the ballast bed), therefore the operator restore the initial track position by using the hydraulic actuators.

The Eq. (1) can be used to evaluate the curvature index  $k_2 = y_2 - y_k$  (see Fig. 2) on the base of the

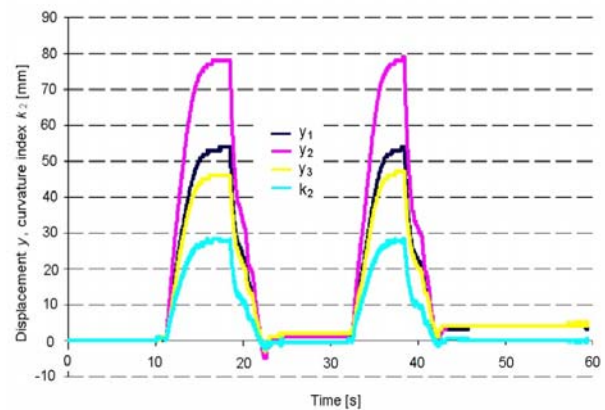

Fig. 15 Time signals of displacement  $y$  and curvature index  $k_2$  of the rail with the axial force  $P = 200$  kN:  $y_1$ —signal of displacement in measurement point 1,  $y_2$ —signal of displacement in measurement point 2,  $y_3$ —signal of displacement in measurement point 3.

measurement data. Then it is possible to present the calculated index  $k_2$  for various values of maximum displacement  $y_2$  and for various longitudinal forces in rails  $P$ . Base on that, the characteristic was approximated by a linear function by the use of the least square method. Adopted linear model of regression let to obtain high values of correlation coefficient  $R^2$  (Fig. 16). The calculated linear equations, derived for the particular experiment are presented below:

$$\text{case } P = 0 \quad k_2(P, y_2) = 0.4889 \cdot y_2 + 0.4185 \quad (3)$$

$$\text{case } P = 100 \text{ kN} \quad k_2(P, y_2) = 0.384 \cdot y_2 + 0.8397 \quad (4)$$

$$\text{case } P = 200 \text{ kN} \quad k_2(P, y_2) = 0.3337 \cdot y_2 + 0.0065 \quad (5)$$

$$\text{case } P = 300 \text{ kN} \quad k_2(P, y_2) = 0.2629 \cdot y_2 + 1.6999 \quad (6)$$

According to earlier assumptions, the slope of the linear characteristics for the different cases of longitudinal forces in the rails is various. Moreover there is a clear dependence that larger value of the longitudinal force cause that the curvature is smaller. The fact is manifested by the less value of the slope.

It has been also affirmed that the character of increment of the appointed indexes in time domain is regular (Fig. 17). The graphs below allow to assess the character of track displacement process performed by the tamping machine in particular the nature of the process (ranges with relatively high and low dynamic of the slewing process).

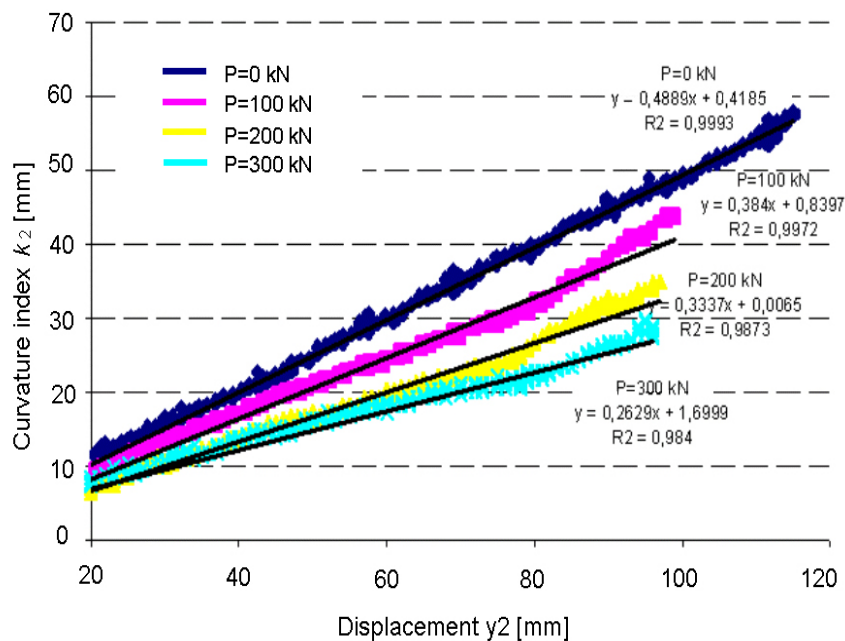

Fig. 16 Regression lines of curvature index  $k_2$  for various value of axial forces P in rails.

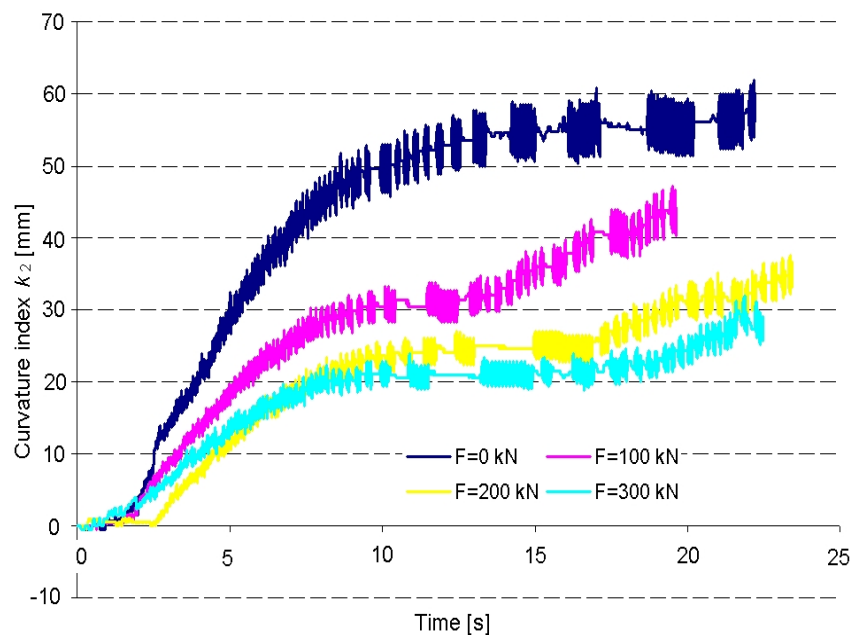

Fig. 17 Comparison of curvature indexes of track for the various value of longitudinal force in rails.

### 5.3 The Process of Longitudinal Force Estimation

The experimental works showed that there is a correlation between the level of longitudinal force in the rails, and defined by the authors the curvature index, which may be designated in the way of measurements. Such measurements make it possible to estimate the

value of longitudinal force in the rails. Crucial to this are nomographs of the relationship between the maximum displacement of the track performed by the tamping machine and a defined index of the curvature. In this article the authors present the only exemplary nomograph, in order to prove the validity of the thesis. However, to implement the discussed methods, it is

necessary to conduct experimental research in a wide range. Assume that in future it will be possible to create an appropriate amount of nomographs for different conditions (type of track structure and its condition), the authors propose the following procedure to estimate level of the axial force in rails:

(1) The first point assumes the preparation of an appropriate amount of nomographs illustrating the relationship between the maximum displacement and defined curvature index. This relationship, as shown in this article, could be linear. Thus, for different values of axial forces in rails  $P \in \{0 \cdot \Delta P, 1 \cdot \Delta P, 2 \cdot \Delta P, \dots, n \cdot \Delta P\}$ , where  $P$  is a step of longitudinal force increment, by the use of the method of least squares, the linear regression functions can be calculated and written as follows:

$$k_2(P_i, y_2) = a(P_i) + b(P_i) \cdot y_2 \quad (7)$$

where:  $P_i = i \cdot \Delta P$ ;  $i = 0, 1, 2, \dots, n$ ;  $P$ —assumed increment of longitudinal force.

(2) Designation of the value of measured displacements  $y_1, y_2, y_3$  in an operating rail track on the way of measurements described in the article. Calculation the curvature index  $k_2$  in case of unknown longitudinal force  $P$ . As that obtained  $y_1, y_2, y_3$  are the time signals, for the calculation could be used the final (maximum) measured value of the displacement;

$$k_2(P, y_2) = y_2 - \left[ y_1 - (y_1 - y_3) \frac{l_{12}}{l_{12} + l_{23}} \right] \quad (8)$$

where:  $y_1, y_2, y_3$  – measured lateral displacements in three points along the track;  $l_{12}, l_{23}$  – distances between the sensors for the transverse displacements measurement;  $P$ —the searched value of longitudinal force in rails.

(3) Basing on the appropriate nomograph (chosen for the given conditions) calculation of the curvature indexes  $k_2(P_i, y_2)$  Eq. (7), which corresponds with the measured displacement  $y_2$  for the various values of force  $P_i$ . The coefficients of the linear characteristics should be read from the chosen nomograph.

(4) Defining the range for the value of index  $k_2(P, y_2)$

$$k_2(P, y_2) \in \langle k_2(P_i, y_2), k_2(P_{i+1}, y_2) \rangle$$

By the use of interpolation method, calculation the value of the longitudinal force  $P$ :

$$P = P_i + \frac{k_2(P_i, y_2) - k_2(P, y_2)}{k_2(P_i, y_2) - k_2(P_{i+1}, y_2)} \cdot \Delta P \quad (9)$$

To illustrate the algorithm, let's assume that during the measurements we obtained the value of maximum lateral displacement  $y_2 = 90$  mm and the calculate curvature index was equal to  $k_2 = 33$  mm. If the presented in Fig. 16 nomograph would be appropriate to the given conditions of the track, where the displacement was measured, we could calculate the followed curvature indexes using the equations (2)÷(7):

$$k_2(0, 90) = 0.4889 \cdot 90 + 0.4185 = 44.4195 \text{ mm},$$

$$k_2(100, 90) = 0.384 \cdot 90 + 0.8397 = 35.3997 \text{ mm},$$

$$k_2(200, 90) = 0.3337 \cdot 90 + 0.0065 = 30.0395 \text{ mm},$$

$$k_2(300, 90) = 0.2629 \cdot 90 + 1.6999 = 25.3609 \text{ mm},$$

Where:

$$k_2(0, 90), k_2(100, 90), k_2(200, 90), k_2(300, 90)$$

—the values of curvature index for the longitudinal forces equal to:  $P = 0$  kN, 100 kN, 200 kN, 300 kN and for the maximum lateral displacement  $y_2 = 90$  mm.

Based on the comparison of appointed indexes it is clear that the longitudinal force in the rails in given track section would be included in the range of  $P_i = 100$  kN and  $P_{i+1} = 200$  kN. And now, using the rule of interpolation Eq. (9), it is easy to estimate the value of the force occurring in rails, by using the transformation given below:

$$P = 100 + \frac{35.3997 - 33}{35.3997 - 30.0395} \cdot (200 - 100) \cong 145 \text{ kN}.$$

## 6. Conclusions

The investigation project [6] was intended to work out a technique to make use of the standard operation of the tamping machine in diagnostics of railway track condition. The point was here primarily to determine the condition of the longitudinal forces in rails. On the basis of the measurements described within the article, the authors proposed a manner of longitudinal force estimation.

The results of the most recent experiments proved the correctness of the thesis, that there is a clear relationship between the curvature of the rail that occurs in the lateral displacement process with the tamping machine, and the existing state of the force in rails. Presented within the article calculations illustrate the manner of utilizing the described measurements to the longitudinal force estimation.

In view of the fact that the presented by the authors study was a pilot phase, the implementation of the methodology requires a significant enlargement of the research program.

## References

- [1] G. Samavedam and A. Kish, Continuous welded rail track buckling safety assurance through field measurements of track resistance and rail force, *Transportation Research Record* 1999, No. 1289.
- [2] C. Sinclair, *Checking rail condition*, BR Research 1996.
- [3] A. Barylski, W. Koc and A. Wilk, Longitudinal forces in railway track and tamping machine shifting sets, *NDT&E International* 8 (1999).
- [4] W. Koc, A. Wilk and S. Grulkowski, Prospects for the tamping machine application in the railway track diagnostics, in: *Railway Engineering-2001, Proceedings of Fourth International Conference on Maintenance & Renewal of Permanent Way, Power & Signalling; Structures & Earthworks*, Engineering Technics Press, Edinburgh, 2001.
- [5] W. Koc and A. Wilk, Investigations of methods to measure longitudinal forces in continuous welded rail tracks using the tamping machine, in: *Proc. IMechE, Part F: J. Rail and Rapid Transit* 223 (2009) (F1).
- [6] W. Koc, A. Wilk, Z. Kedra, P. Dobrowolski, S. Grulkowski and G. Kostro, The use of tamping machine for diagnostic of continuous railway rail track, in: *Railway Engineering-2005, Proceedings of Eight International Conference on Maintenance & Renewal of Permanent Way, Power & Signalling, Structures & Earthworks*, Engineering Technics Press, Edinburgh, 2005.