

Article

Thermodynamic Cycle Concepts for High-Efficiency Power Plants. Part B: Prosumer and Distributed Power Industry

Krzysztof Kosowski ¹, Karol Tucki ^{2,*} , Marian Piwowarski ¹ , Robert Stępień ¹,
Olga Orynych ^{3,*}  and Wojciech Włodarski ¹ 

¹ Faculty of Mechanical Engineering, Gdansk University of Technology, Gabriela Narutowicza Street 11/12, 80-233 Gdansk, Poland; kosowski@pg.gda.pl (K.K.); marian.piwowarski@pg.edu.pl (M.P.); rstepien@pg.edu.pl (R.S.); wwlodar@pg.edu.pl (W.W.)

² Department of Organization and Production Engineering, Warsaw University of Life Sciences, Nowoursynowska Street 164, 02-787 Warsaw, Poland

³ Department of Production Management, Bialystok University of Technology, Wiejska Street 45A, 15-351 Bialystok, Poland

* Correspondence: karol_tucki@sggw.pl (K.T.); o.orynych@pb.edu.pl (O.O.)

Received: 9 March 2019; Accepted: 5 May 2019; Published: 9 May 2019



Abstract: An analysis was carried out for different thermodynamic cycles of power plants with air turbines. A new modification of a gas turbine cycle with the combustion chamber at the turbine outlet has been described in the paper. A special air by-pass system of the combustor was applied, and in this way, the efficiency of the turbine cycle was increased by a few points. The proposed cycle equipped with an effective heat exchanger could have an efficiency higher than a classical gas turbine cycle with a regenerator. Appropriate cycle and turbine calculations were performed for micro power plants with turbine output in the range of 10–50 kW. The best arrangements achieved very high values of overall cycle efficiency, 35%–39%. Such turbines could also work in cogeneration and trigeneration arrangements, using various fuels such as liquids, gaseous fuels, wastes, coal, or biogas. Innovative technology in connection with ecology and the failure-free operation of the power plant strongly suggests the application of such devices at relatively small generating units (e.g., “prosumers” such as home farms and individual enterprises), assuring their independence from the main energy providers. Such solutions are in agreement with the politics of sustainable development.

Keywords: thermodynamic cycle concepts; efficiency; decentralized energy; sustainability; fuels

1. Introduction

Values related to respect for the natural environment are becoming a common phenomenon in many countries. Contemporary fears result from limited access to natural resources, degradation of the environment, and continuous energy demand. This results in the main threat to the socio-economic development of current and future generations. Transformations taking place in the market economy and environmental protection should account for the search for new technological solutions in the field of energy. Only a balanced and cautious approach to such actions can effect an increase in energy efficiency.

The energetics play an extremely important role among other areas of sustainability. In addition to energy security, sustainable energy is extremely important, and should be perceived as a durable and environmentally friendly access to heat and electricity.

Striving for methods of energy production and distribution that are least invasive for the natural environment should be a focus in the economic management of this good, and as a consequence, should promote an increase in efficiency and a reduction of pressure on the environment [1].

Considering the concept of sustainable development, it seems necessary to strive to create an entire energy system that is able to meet the requirements of this concept. Such actions can contribute to the implementation of the principle of sustainable development, and at the same time, bring tangible benefits to the environment and to prosumers as well.

Dispersed energy, including the energy generated by prosumers, shows that the idea of sustainable development has an impact on the functioning of the economy. It is seen as one of the elements of improving the local security of energy supply to complement the centralized energy supply system [2]. It is the consumer/prosumer that will have an impact on the changes in the energy sector, which will be based on the correlation of various types of fuels that are often available under local systems [3].

The excessive turnover of natural raw materials creates a number of regional conflicts, leading to a lack of energy stabilization and an increase of ecological threats. The constant pursuit of increased energy efficiency, including the development of competitive fuel and energy markets, must take into account the reduction of the aggressive and devastating development pace of these rational changes.

Currently, many countries are trying to develop a new concept of energy development which can evaluate their energy systems in terms of compliance with sustainable development policy [4]. Such observations may lead to the search for improved energy management systems [5]. Research on the potential inherent in such systems may prove to be a chance for the further development of a given region. This is one of the challenges for the domestic energy sector.

The aim of this research is to indicate the possibility of implementing high-efficiency turbine systems for prosumer's energetics within the concept of sustainable development and energy security.

The Polish system is characterized by a relatively low energy production efficiency. A drawback of the national power generation sector is the relatively low efficiency of energy production from coal [6–8]. For distributed power generation, the efficiencies of small electric power plants are even lower [9–11], and the organic Rankine cycle (ORC)-based thermal power plants reach an efficiency only slightly exceeding ten percent [12–14]. Within the framework of the prosumer power industry, there are no solutions that can help generate energy 24 h a day [15–17]. As part of the development of the microelectric plant, it is possible to use micro power turbines [18–21] and bladeless adhesion turbines [22,23]. Solar collectors are currently very popular, but can only operate during daylight hours [24–26]. Other solutions which do not make use of solar energy have relatively low efficiencies, which makes their installation and operation rather unprofitable.

2. Materials and Methods

Part A in [27] presents the results of an efficiency analysis of modified air turbine cycles intended to work in large electric power plants. The analysis of small electric power plants (from several to several tens of kilowatts) presented here was based on the assumption that the maximal turbine inlet temperature is between 850 and 900 °C. Moreover, much lower efficiency values were assumed for cycle components [28,29]. For instance, the assumed efficiency of the turbine was 82%, compressor—80%, electric current generator—90%, and combustion chamber—95%. Assumptions adopted for the analysis are presented in Table 1.



Table 1. Assumptions adopted for the design analysis of turbine set variants.

Parameter	Unit	Value	Description
$\eta_{\text{compressor}}$	[-]	0.800	
η_{turbine}	[-]	0.820	
η_{mech}	[-]	0.980	
η_{leakage}	[-]	0.980	
$\eta_{\text{generator}}$	[-]	0.900	
$\eta_{\text{comb.cham}}$	[-]	0.950	
p_i/p_{i-1}	[-]	0.995	filter
p_i/p_{i-1}	[-]	0.995	exhaust gases duct/filter/silencer
p_i/p_{i-1}	[-]	0.99	combustion chamber
p_i/p_{i-1}	[-]	0.99	regenerator

The pressure drop in gas turbine combustion chambers is usually about 2%, or even 5%. However, in our analysis we considered the possibilities of building high-efficiency gas turbines with small output. Thus, our investigations were carried out on experimental stands with specially designed combustion chambers and regenerators, where pressure losses for some variants were even lower than 1% [15,17].

Like for large power plants, highly efficient heat exchangers were used [30–32]. Five different variants of gas turbine set configuration were analyzed (Figure 1): in each variant, the heat exchanger (called the regenerator) played a key role. Taking into account a micro-scale of the considered power plant, only the compact heat exchangers with passive techniques of heat transfer augmentation were suitable. Heat exchangers with cylindrical mini-channels [33,34] and plate heat exchangers [35,36] were preferable. Moreover, heat exchangers with micro-jet technology are very promising [37], which besides the high thermal performance, are characterized by low flow resistance. The selected plate heaters with minichannels were characterized by a very high effectiveness (higher than 95%, final temperature difference lower than 20 °C), low pressure losses (lower than 1%), while leakages were significantly reduced by applying 3D printing technology.

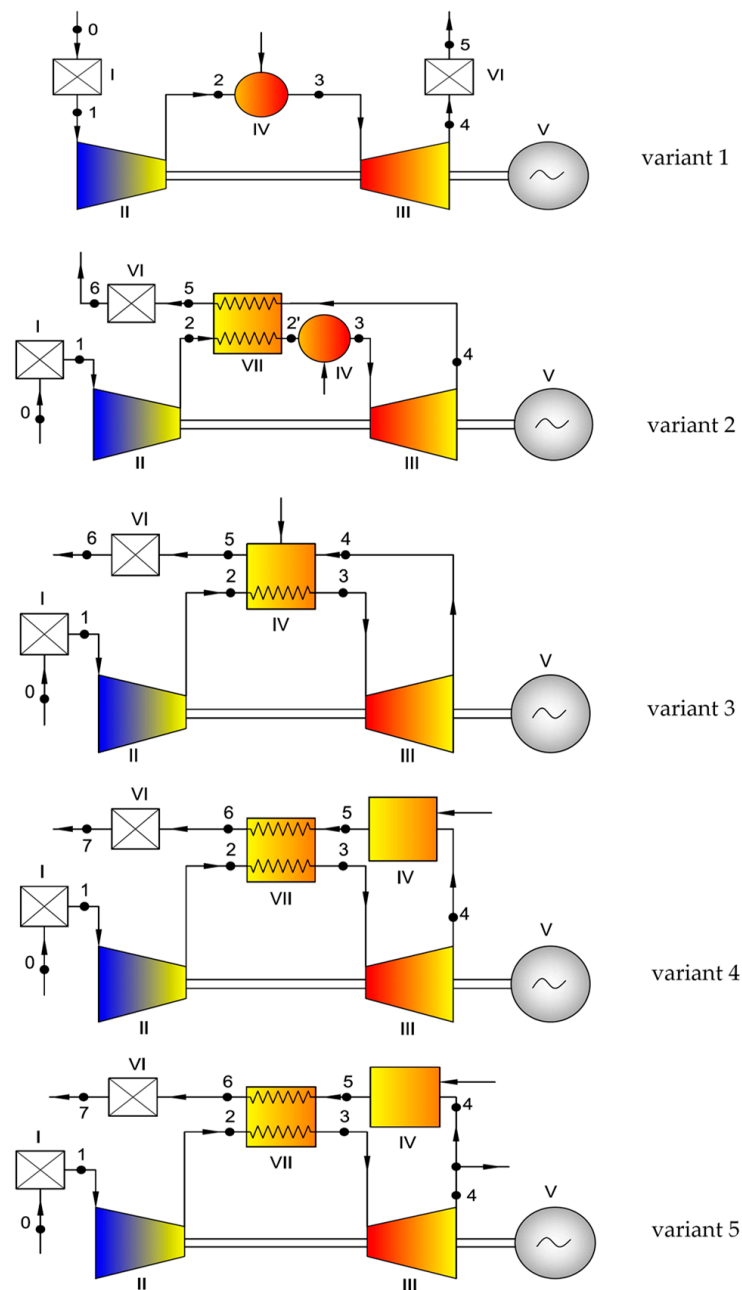

Figure 1. Turbine set arrangements being analyzed. Variant 1: Turbine set operating according to the simple open cycle; Variant 2: Turbine set operating according to the open cycle with a regenerator; Variant 3: Turbine set operating according to the open cycle with a combustion chamber at the turbine exit. The air introduced to the combustion chamber had a temperature equal to the temperature just behind the turbine and it could be compared to the situation when the effectiveness of the regenerator equaled 1. Therefore, the efficiency of variant 3 could be higher than the efficiency of other variants. This solution has been well known for years [38], but it was not used in practice due to the properties of the materials for regenerators/combustors which did not allow the application of high temperature before the turbines. Nowadays, due to technological progress we can overcome these problems, and propose variant 3 as a realistic solution. Variant 4: Turbine set operating according to the open cycle with an external combustion chamber at the turbine exit and a high-temperature heat exchanger; Variant 5: Turbine set operating according to the open cycle with partial bypassing of the external combustion chamber at the turbine exit and with a high-temperature heat exchanger.

3. Results and Discussion

The assumptions adopted in the Introduction formed the basis for the thermodynamic analysis of the above power plant variants. The relative efficiency values obtained for these variants after assuming the turbine inlet temperature $T_3 = 900\text{ }^\circ\text{C}$ are shown in Figure 2, with variant 1 as the reference, while Figure 3 shows optimal compression values for individual variants.

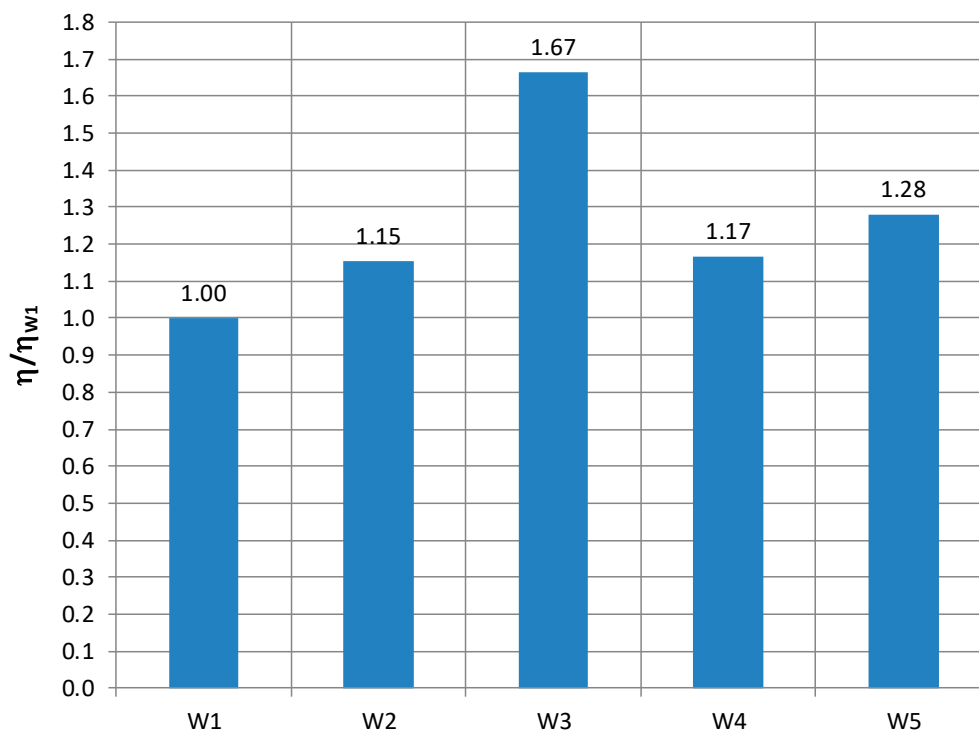

Figure 2. Relative efficiency of the analyzed turbine sets.

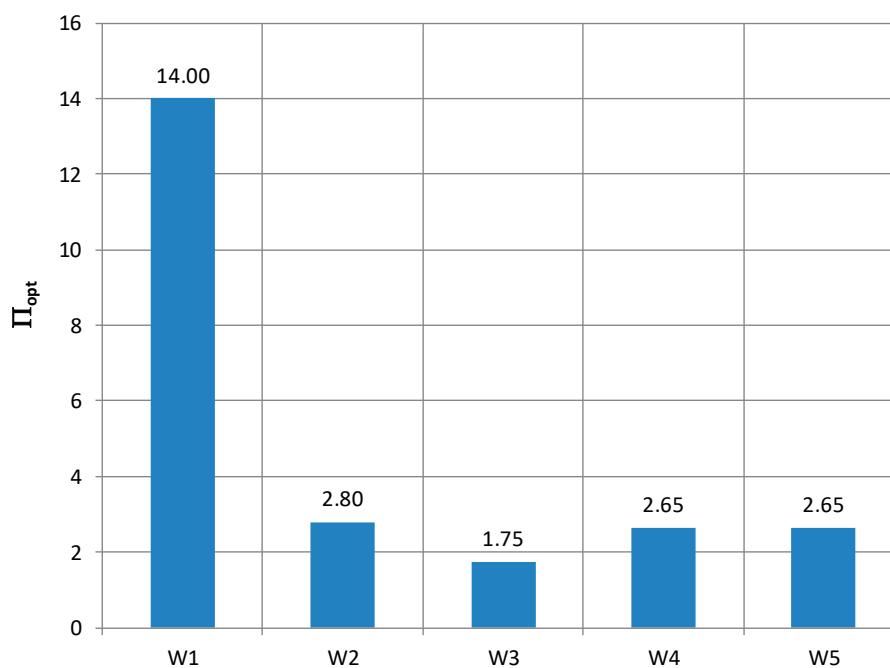

Figure 3. Optimal pressure ratio of the analyzed turbine sets.

Compared to the analysis performed for large power plants (Part A), decreasing the efficiency of cycle components (for very small power values) resulted, to some extent, in the decrease of relative efficiency differences between variants [39–41], and in the reduction of optimal compression values [42]. On the other hand, the effect of the efficiencies of heat exchangers were more noticeable. For instance, decreasing the final temperature difference $T_5 - T_2$ from 50 to 10 °C in variant 3 increased the efficiency by about 11.5% (compared to 9.5% for large power plants, Part A). From a practical point of view, the solutions corresponding to thermodynamic cycles of variant 3 and variant 5 seem to be most attractive (Figure 1). In this latter case, the air flow bypassing the combustion chamber could be directed to the high-temperature exchanger or used for cogeneration purposes [43]. The combustion chamber in variant 3 was rather strange for the gas turbine community, but the way of heating the working medium from a small temperature to a high temperature by an external burner is well known in various other power plants. This idea is applied, for example, in steam boilers for electric power plants or small water heaters for home applications.

In variant 5, the working fluid was bled, and in this way the heat delivered to the combustion chamber was reduced and the outlet temperature T_6 was decreased, and the cycle efficiency was increased. The amount of the bled stream depended on the final temperature difference in the heat exchanger and on the compressor pressure ratio. In the analyzed variants, the bled stream varied from 3% to 16% of the main stream. For the optimum pressure ratio ($\Pi = 2.65$), the final temperature difference in the heat exchanger was 10 °C, and the bled stream amounted to 9.1%.

It should be emphasized that the use of a high-efficiency generator (small final temperature difference) led to a reduction of the optimal compression value as compared to the basic system without a regenerator. The effect of compression on the efficiency of individual variants of turbine sets is shown in Figure 4. Such comparatively low pressures led to an increase of the specific volume of the working medium, and to an increase of the volumetric flow rate, which facilitated the design and operation of the flow parts of the compressors and turbines.

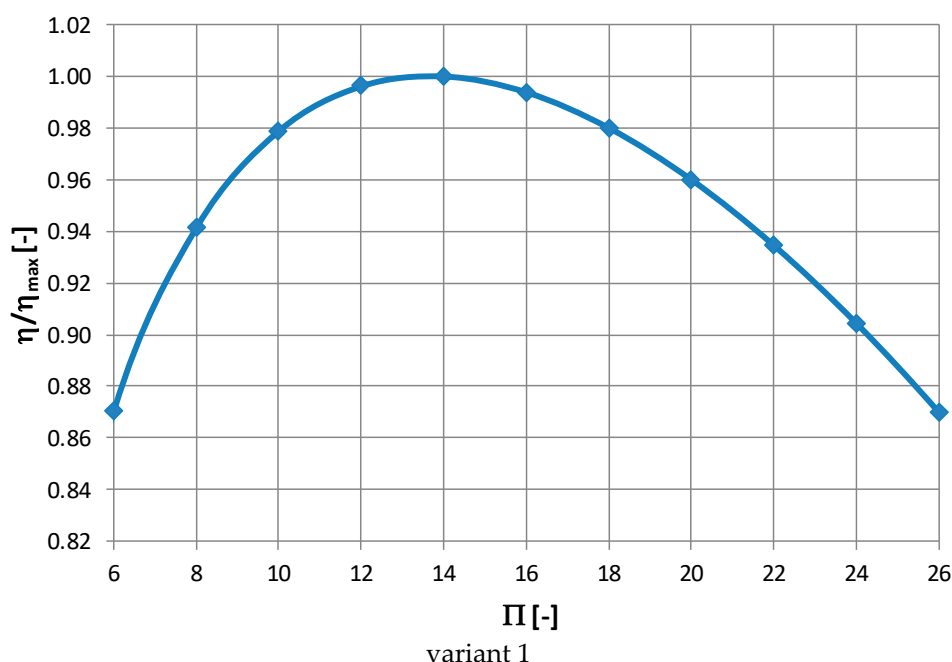
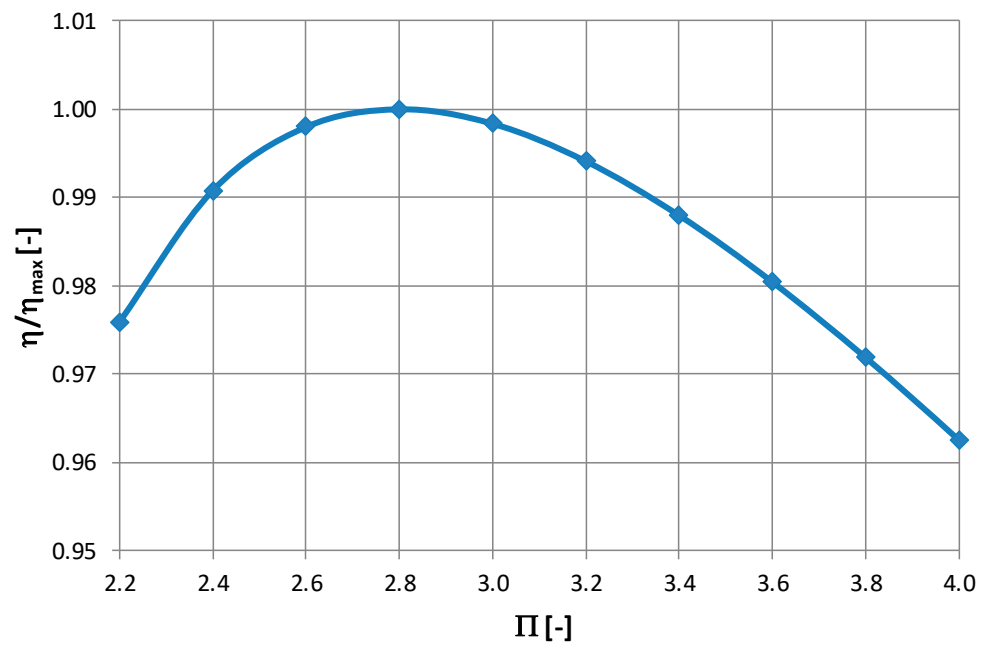
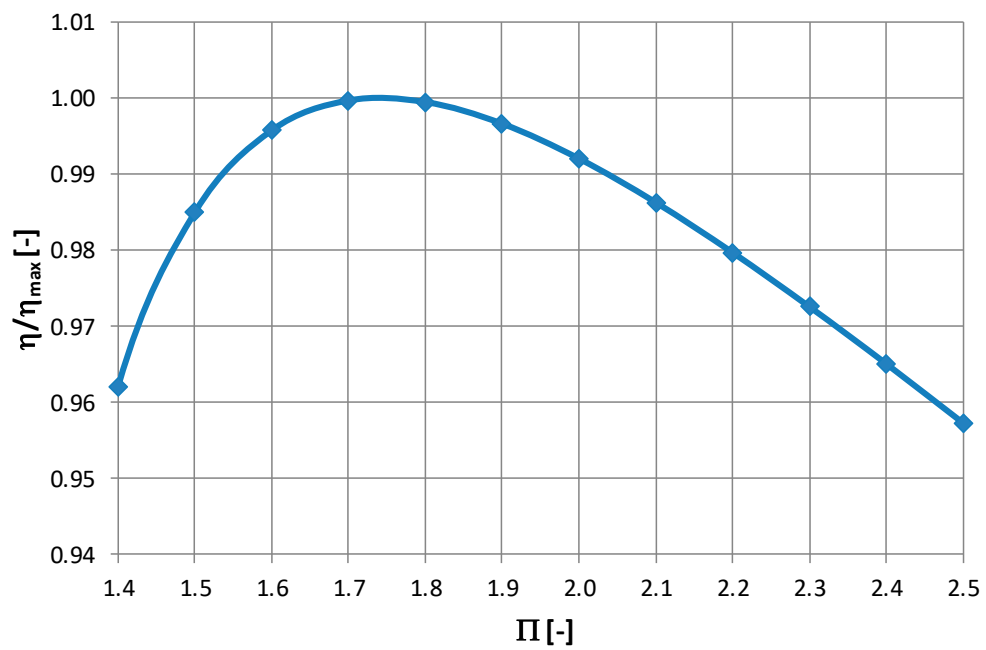

Figure 4. Cont.



variant 2



variant 3

Figure 4. Cont.

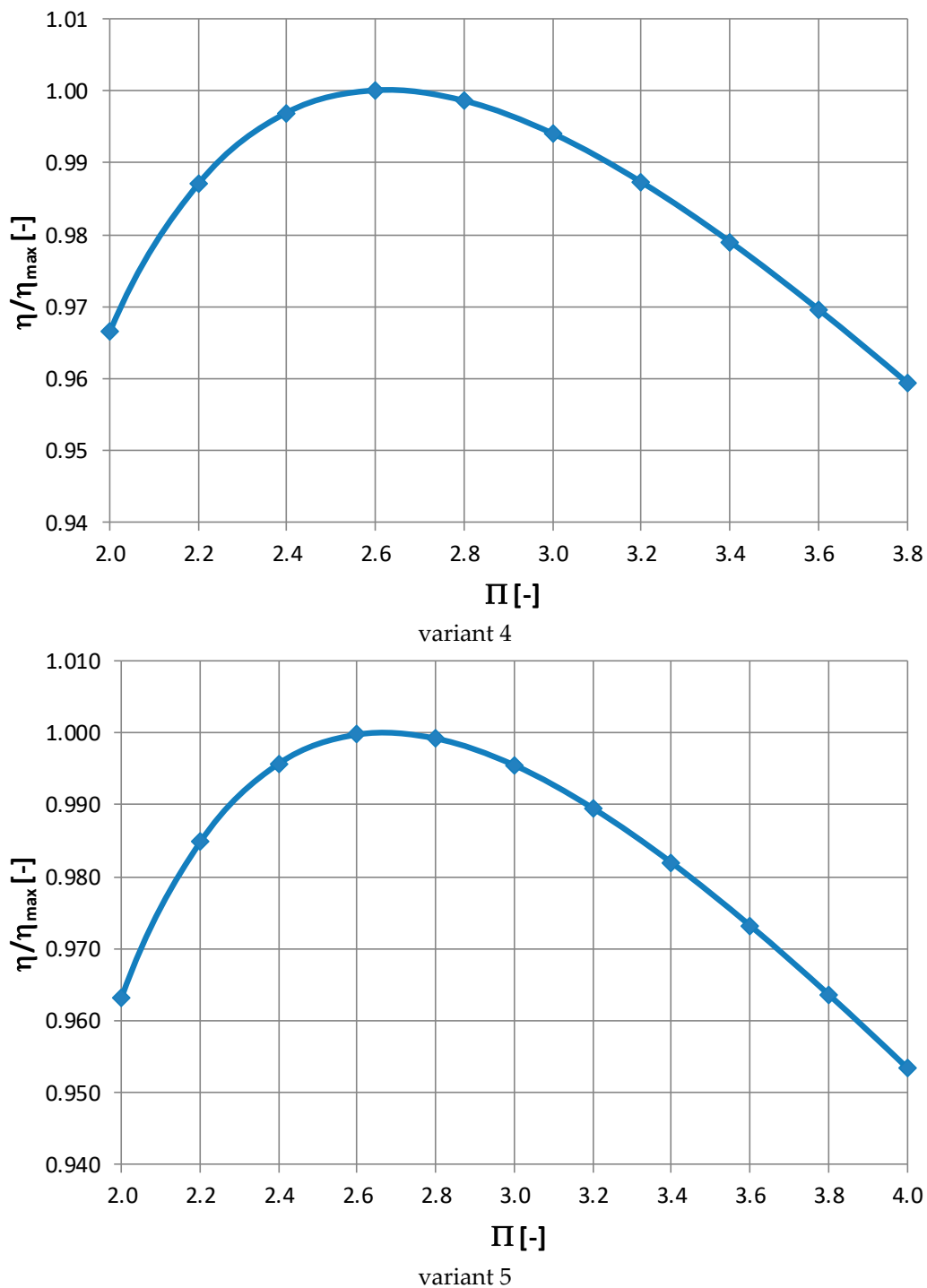

Figure 4. The influence of pressure ratio on the efficiency of the analyzed variants of turbine sets.

Relatively high turbine set efficiency was obtained in variant 3, which could reach as much as 39% at the turbine inlet temperature equal to 900 °C. For variant 5, the efficiency was on the order of 35%, but this variant allows the hot air bypassing the combustion chamber to be used for cogeneration purposes, for instance. Moreover, this variant was adjusted for cooperation with an external combustion chamber fed with practically arbitrary fuel. Based on this variant, preliminary design calculations were performed for a series of turbine sets, with powers ranging from 10 to 50 kW. Designs were worked out for compressors, turbines, heat exchangers, and selected combustion chamber variants (for

different chemical compositions of burned biogas). The main parameters of the designed turbine units are shown in Table 2.

Table 2. Parameters of the designed turbine units.

Parameter	10 kW Turbine	35 kW Turbine	50 kW Turbine
pressure ratio	2.3	2.3	2.3
temperature in front of the turbine	850 °C	850 °C	850 °C
rotor speed	120,000 rpm	65,000 rpm	55,000 rpm
compressor	1 stage, radial	1 stage, radial	1 stage, radial
turbine	1 stage, axial	1 stage, axial	1 stage, axial

Figure 5 shows a turbine set with visible compressor and turbine flow parts, while Figure 6 presents selected microturbine set variants, including the variant adjusted for cooperation with an arbitrary combustion chamber, and the variant with the boiler which can burn practically arbitrary fuel (with an additional chamber for partial pyrolysis).

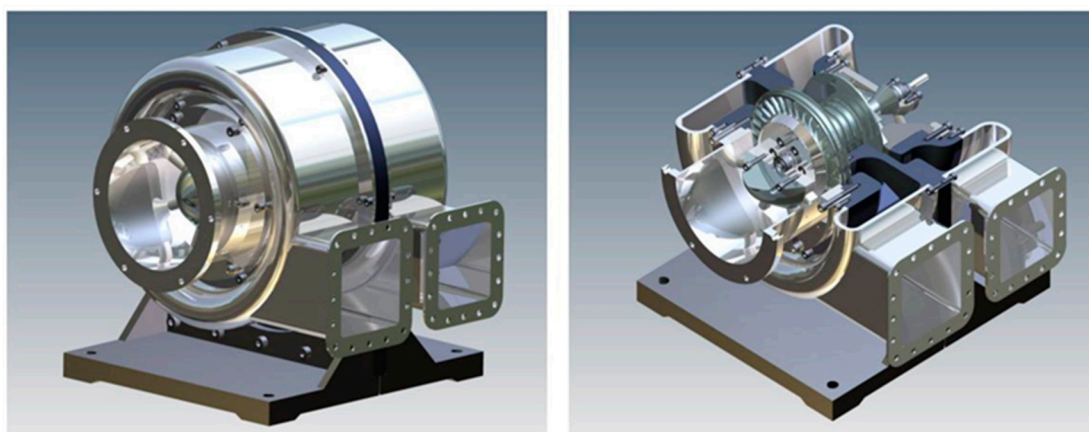

Figure 5. The 35-kW air turbine set (compressor and turbine).

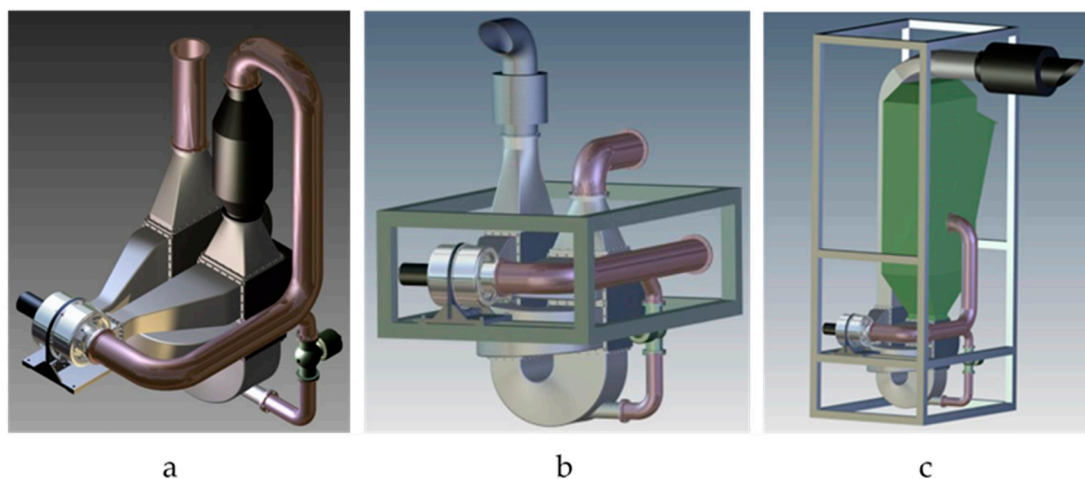

Figure 6. Power plant for distributed/prosumer power industry: (a) with external combustion chamber; (b) adjusted for cooperation with arbitrary combustion chamber; (c) with boiler for practically arbitrary fuel.

4. Conclusions

The article proposes and analyzes a unique small power plant that can burn arbitrary fuel. The uniqueness of this solution is testified by:

- The unique design and technological solution;
- The low parameters of working medium (pressure and temperature);
- The working medium is clean air, which has numerous advantages compared to poisonous, combustible, physically unstable, expensive, and environmentally hazardous working media used in ORC power plants. This property of the working medium increases the time of power plant failure-free operation (in contrast to gas turbines and piston engines currently in operation);
- A high efficiency of power generation—higher by several or even more than ten percentage points than the efficiencies of other competing solutions.

This high efficiency of the device producing electric energy (also heat and cold, if necessary), along with its reliability of operation, ensures long lasting profitability for its users (i.e., prosumers and small energy producers). Entry to the market with this product fills the gap in the supply of such devices. With its further use for own purposes or sale, the possibility of profitable energy production from different types of fuels makes the prosumers (households, small businesses, etc.) independent from the thermal and electric power plant and/or electric network.

Part B of the article gives the description of the proposed thermal cycle and its sample execution, complemented with preliminary designs of a series of turbine sets with powers ranging from 5 to 50 kW (Figure 1).

The results of the design analyses confirm that good conditions can be created for the production, distribution, and service of power plants for the distributed and prosumer power industry:

- Turbine sets with powers from 3 to 10 kW for cooperation with gas boilers for the prosumer power industry;
- Turbine sets with powers from 20 to 100 kW for small production plants and agro-power engineering;
- Turbine sets with powers from 100 to 500 kW (1000 kW) for small power plants, small production plants, sewage treatment plants, and landfill sites.

The proposed turbine sets can be adjusted for operation in cogeneration systems (simultaneous production of heat and electrical energy) and trigeneration systems (simultaneous production of electrical energy, heat, and cold).

They can also be adapted for burning various fuels (liquid and gas fuels, coal, wood, biogas, pellets, garbage, waste, etc.), and their advantage is that the turbine and compressor flow parts remain clean during the entire useful life of the power plant, without exhaust pollution. Consequently, they do not need frequent repairs and cleaning. This is a particular advantage, compared, for instance, to biogas-fed piston engines working on landfill sites and in cleaning plants. The proposed modifications of turbine sets with combustion chambers at turbine exit can be successfully used in compressed air energy storage (CAES) systems. In these systems, the combustion chamber works permanently at a constant pressure that is close to the atmospheric pressure. This is a great advantage, because in typical applications, the combustion chamber works at the very high and changing pressure of the air flowing out of the compressed air storage tank.

Examples of high-efficiency turbine systems for public and prosumer power industries which were presented in Part A and Part B of the article can be modified and expanded in order to reach even higher efficiencies. Higher efficiency can be reached by:

- Optimizing cycle parameters;
- Using multi-pressure waste heat boilers;
- Increasing the gas turbine inlet temperature;
- Expanding the gas cycle (inter-stage coolers, sequential combustion chambers).

It seems that the efficiency of turbine sets for micro-energetics will clearly increase after the introduction of new high-efficiency thermodynamic cycles. For example, intensive work is currently underway on the technical implementation of a turbine set working according to the so-called Ericsson's

circuit (with efficiency equal to Carnot's efficiency). Figure 7 shows an example of an experimental variant of a gas turbine working according to the Ericsson cycle with a design efficiency above 45%.

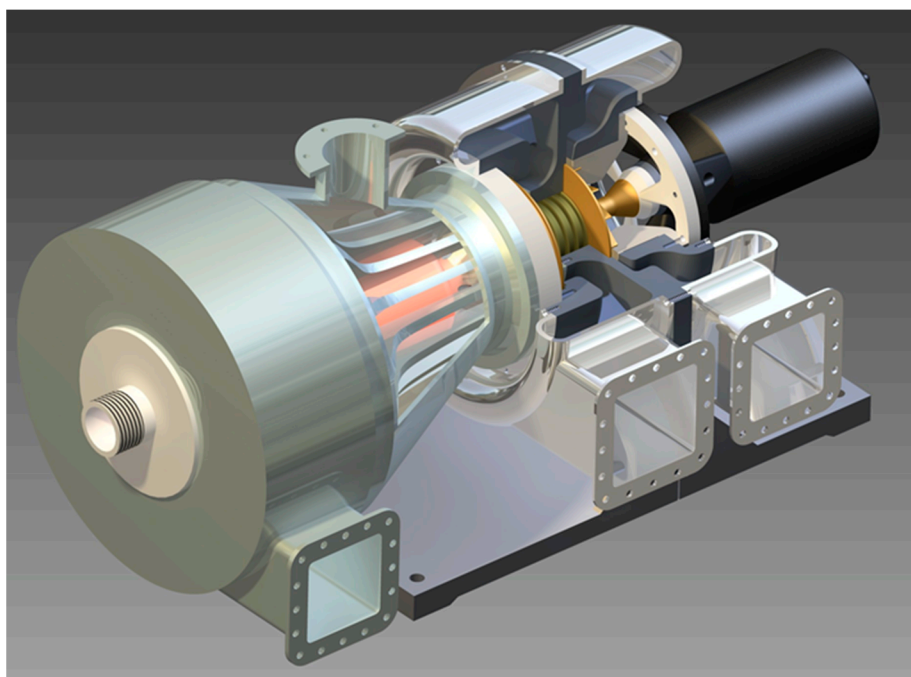

Figure 7. Example of an experimental variant of a gas turbine working according to the Ericsson cycle.

Summarizing the above considerations, it should be noted that, after their implementation as the prosumer's type of energy system, the examples of high-efficiency turbine systems that can be supplied with various types of fuels can be considered as integrated activities at particular levels that contribute to the development of a sustainable market. The local energy sector needs to be modernized to introduce low-carbon and innovative models. Solutions increasing the efficiency of energy consumption give the possibility of diversification, and enable a reduction of energy consumption, as well as the primary consumption. Such effective technological changes and layout improvements can be one of the stages of combating the energy crisis, in addition to being an element of strategic development in shaping the national energy generation sector.

Author Contributions: Conceptualization, K.K., M.P., R.S., and W.W.; Methodology, K.T. and O.O.; Validation, K.K. and M.P.; Investigation, R.S. and W.W.; Writing—original draft preparation, K.T. and O.O.; Funding acquisition, K.K.

Funding: This research received no external funding.

Acknowledgments: The authors wish to express their deep gratitude to Gdansk University of Technology for the financial support given to the present publication (Krzysztof Kosowski). The research was carried out under the financial support obtained from the research subsidy of the Faculty of Engineering Management (WIZ) of Bialystok University of technology (Olga Orynycz).

Conflicts of Interest: The authors declare no conflict of interest. The funders had no role in the design of the study; in the collection, analyses, or interpretation of data; in the writing of the manuscript, or in the decision to publish the results.

References

1. Orynycz, O.; Świć, A. The Effects of Material's Transport on Various Steps of Production System on Energetic Efficiency of Biodiesel Production. *Sustainability* **2018**, *10*, 2736. [[CrossRef](#)]
2. Oberst, C.A.; Schmitz, H.; Medlener, R. Are Prosumer Households That Much Different? Evidence from Stated Residential Energy Consumption in Germany. *Ecol. Econ.* **2019**, *158*, 101–115. [[CrossRef](#)]



3. Kubli, M.; Loock, M.; Wüstenhagen, R. The flexible prosumer: Measuring the willingness to co-create distributed flexibility. *Energy Policy* **2018**, *114*, 540–548. [[CrossRef](#)]
4. Meng, Y.; Yang, Y.; Chung, H.; Lee, P.; Shao, C. Enhancing Sustainability and Energy Efficiency in Smart Factories: A Review. *Sustainability* **2018**, *10*, 4779. [[CrossRef](#)]
5. Chai, K.; Yeo, C. Overcoming energy efficiency barriers through systems approach—A conceptual framework. *Energy Policy* **2012**, *46*, 460–472. [[CrossRef](#)]
6. Kamiński, J.; Kudełko, M. The prospects for hard coal as a fuel for the Polish power sector. *Energy Policy* **2010**, *38*, 7939–7950. [[CrossRef](#)]
7. Szczerbowski, R.; Ceran, B. Development perspectives of the Polish power generation sector according to the climate preservation conference COP21 policies. *E3s Web Conf.* **2017**, *14*, 1–10. [[CrossRef](#)]
8. Stygar, M.; Brylewski, T. Contemporary low-emissions hydrogen-based energy market in Poland: Issues and opportunities, part II. *Int. J. Hydrog. Energy* **2015**, *40*, 13–24. [[CrossRef](#)]
9. Stępiak, D.; Piwowarski, M. Analyzing selection of low-temperature medium for cogeneration micro power plant. *Pol. J. Environ. Stud.* **2014**, *23*, 1417–1421.
10. Kosowski, K.; Piwowarski, M.; Stępień, R.; Włodarski, W. Design and investigations of the ethanol microturbine. *Arch. Thermodyn.* **2018**, *39*, 41–54.
11. Budzianowski, W.M. Target for national carbon intensity of energy by 2050: A case study of Poland's energy system. *Energy* **2012**, *46*, 575–581. [[CrossRef](#)]
12. Włodarski, W. Experimental investigations and simulations of the microturbine unit with permanent magnet generator. *Energy* **2018**, *158*, 59–71. [[CrossRef](#)]
13. Kosowski, K.; Włodarski, W.; Piwowarski, M.; Stępień, R. Performance characteristics of a micro-turbine. *Adv. Vib. Eng.* **2014**, *2*, 341–350.
14. Wierzbowski, M.; Filipiak, I.; Lyzwa, W. Polish energy policy 2050—An instrument to develop a diversified and sustainable electricity generation mix in coal-based energy system. *Renew. Sustain. Energy Rev.* **2017**, *74*, 51–70. [[CrossRef](#)]
15. Kosowski, K.; Domachowski, Z.; Próchnicki, W.; Kosowski, A.; Stępień, R.; Piwowarski, M.; Włodarski, W.; Ghaemi, M.; Tucki, K.; Gardzilewicz, A.; et al. *Steam and Gas Turbines with the Examples of Alstom Technology*; Alstom: Saint-Quen, France, 2007; ISBN 978-83-925959-3-9.
16. Kasztelewicz, Z.; Patyk, M. The modern and efficiently coal power plants strategic challenge for Polish. *Energy Policy J.* **2015**, *18*, 45–60.
17. Chmielniak, T. Technologie energetyczne. *Wydaw. Politech. Śląskiej* **2008**, 230–560. (In Polish)
18. Badami, M.; Chicco, G.; Portoraro, A.; Romaniello, M. Micro-multigeneration prospects for residential applications in Italy. *Energy Convers. Manag.* **2018**, *166*, 23–36. [[CrossRef](#)]
19. Mikielwicz, J.; Piwowarski, M.; Kosowski, K. Design analysis of turbines for co-generating micro-power plant working in accordance with organic rankine's cycle. *Pol. Marit. Res.* **2009**, *1*, 34–38. [[CrossRef](#)]
20. Piwowarski, M.; Kosowski, K. Design analysis of combined gas-vapour micro power plant with 30 kw air turbine. *Pol. J. Environ. Stud.* **2014**, *23*, 1397–1401.
21. Wu, X.; Shen, J.; Li, Y.; Lee, K.Y. Steam power plant configuration, design, and control. *Wires Energy Environ.* **2015**, *4*, 537–563. [[CrossRef](#)]
22. Bugge, J.; Kjør, S.; Blum, R. High-efficiency coal-fired power plants development and perspectives. *Energy* **2006**, *31*, 1437–1445. [[CrossRef](#)]
23. Lampart, P.; Kosowski, K.; Piwowarski, M.; Jędrzejewski, L. Design analysis of tesla micro-turbine operating on a low-boiling medium. *Pol. Marit. Res.* **2009**, *1*, 28–33. [[CrossRef](#)]
24. Bejan, A. *Advanced Engineering Thermodynamics*; John Wiley & Sons: Hoboken, NJ, USA, 2016; pp. 394–460.
25. Zaporowski, B. Energy and Economic Effectiveness of Electricity Generation Technologies of the Future. *Acta Energ.* **2014**, *2*, 156–161. [[CrossRef](#)]
26. Paska, J.; Surma, T. Electricity generation from renewable energy sources in Poland. *Renew. Energy* **2014**, *71*, 286–294. [[CrossRef](#)]
27. Kosowski, K.; Tucki, K.; Piwowarski, M.; Stępień, R.; Orynych, O.; Włodarski, W.; Bączyk, A. Thermodynamic cycle concepts for high-efficiency power plans. Part A: Public power plants 60+. *Sustainability* **2019**, *11*, 554. [[CrossRef](#)]
28. Kotowicz, J.; Brzeczek, M. Analysis of increasing efficiency of modern combined cycle power plant: A case study. *Energy* **2018**, *153*, 90–99. [[CrossRef](#)]



29. Moran, M.J.; Shapiro, H.N.; Boettner, D.D.; Bailey, M.B. *Fundamentals of Engineering Thermodynamics*, 8th ed.; John Wiley & Sons: Hoboken, NJ, USA, 2014; pp. 425–696.
30. Katulić, S.; Cehil, M.; Schneider, D.R. Thermodynamic efficiency improvement of combined cycle power plant's bottom cycle based on organic working fluids. *Energy* **2018**, *147*, 35–50. [[CrossRef](#)]
31. Zhang, Y.; Li, H.; Han, W.; Bai, W.; Yang, Y.; Yao, M.; Wang, Y. Improved design of supercritical CO₂ Brayton cycle for coal-fired power plant. *Energy* **2018**, *155*, 1–14. [[CrossRef](#)]
32. Chmielniak, T.; Ziebig, A. *Obiegi Ciepłne Nadkrytycznych Bloków Węglowych*; Wydawnictwo Politechniki Śląskiej: Gliwice, Poland, 2010; pp. 19–43. (In Polish)
33. Wajs, J.; Mikielwicz, D.; Jakubowska, B. Performance of the domestic micro ORC equipped with the shell-and-tube condenser with minichannels. *Energy* **2018**, *157*, 853–861. [[CrossRef](#)]
34. Chordia, L. High Temperature Heat Exchanger Design and Fabrication for Systems with Large Pressure Differentials. Final Scientific/Technical Report 2017. Available online: www.osti.gov/servlets/purl/1349235 (accessed on 12 April 2019).
35. Mikielwicz, J.; Wajs, J. Possibilities of heat transfer augmentation in heat exchangers with minichannels for marine applications. *Pol. Marit. Res.* **2017**, *24*, 133–140. [[CrossRef](#)]
36. Zhang, X.; Keramati, H.; Arie, M.; Singer, F.; Tiwari, R.; Shooshtari, A.; Ohadi, M. Recent developments in high temperature heat exchangers: A review. *Front. Heat Mass Transf.* **2018**, *11*, 1–14.
37. Wajs, J.; Mikielwicz, D.; Fornalik-Wajs, E.; Bajor, M. High performance tubular heat exchanger with minijet heat transfer enhancement. *Heat Transf. Eng.* **2018**, 1–12. [[CrossRef](#)]
38. Masłowski, L.A. *Ship Gas Turbines*; Sudostroene: Leningrad Region, Russia, 1973. (In Russian)
39. Beer, J.M. High efficiency electric power generation: The environmental role. *Prog. Energy Combust. Sci.* **2007**, *33*, 107–134. [[CrossRef](#)]
40. Gambini, M.; Vellini, M. High Efficiency Cogeneration: Performance Assessment of Industrial Cogeneration Power Plants. *Energy Procedia* **2014**, *24*, 1255–1264. [[CrossRef](#)]
41. Ibrahim, T.K.; Mohammed, M.K.; Awad, O.I.; Abdalla, A.N.; Basrawi, F.; Mohammed, M.N.; Najafi, G.; Mamat, R. A comprehensive review on the exergy analysis of combined cycle power plants. *Renew. Sustain. Energy Rev.* **2018**, *90*, 835–850. [[CrossRef](#)]
42. Gupta, M.; Kumar, R. Optimization of a Turbine Used in Coal Fired Thermal Power Plants Based on Inlet Steam Temperature Using Thermoconomics. *Int. J. Recent Adv. Mech. Eng.* **2015**, *4*, 39–44. [[CrossRef](#)]
43. Miller, B.G. Clean Coal Technologies for Advanced Power Generation. In *Clean Coal Engineering Technology*, 2nd ed.; Butterworth-Heinemann: Oxford, UK, 2017; pp. 261–308.



© 2019 by the authors. Licensee MDPI, Basel, Switzerland. This article is an open access article distributed under the terms and conditions of the Creative Commons Attribution (CC BY) license (<http://creativecommons.org/licenses/by/4.0/>).